

INSTALLATION MANUAL

Condair HumiLife – the efficient ERV solution
Condair MD

Thank you for choosing Condair

Important!

Please enter the system data listed below during commissioning.

Installation date (DD/MM/YYYY):

Commissioning date (DD/MM/YYYY):

Installation site:

Model:

Serial number:

Supply water hardness at the installation site:

Supply water pH value at the installation site:

Proprietary rights

This document and the information disclosed herein are proprietary data of Condair Group AG. This manual (including extracts hereof) may not be reproduced or passed on, nor may the contents thereof be used or passed on to any third party without the written permission of Condair Group AG. Any infringements are punishable and entail a liability for damages.

Liability

Condair Group AG is not liable for any damages incurred as a result of poorly executed installation, improper operation or the use of components or equipment not approved by Condair Group AG.

Copyright notice

© Condair Group AG, All rights reserved

Technical modifications reserved

Table of Contents

1	Introduction	5
1.1	First things first!	5
1.2	Notes on installation manual	5
2	For your safety	7
3	Product overview	9
3.1	Model overview	9
3.2	Product labelling	9
3.3	System overview Condair MD	10
3.4	Scope of delivery	11
3.5	Options	11
3.6	Accessories	12
4	Checking delivery/storage and transport	13
4.1	Checking delivery	13
4.2	Storage and transport	13
5	Installation overview	14
5.1	Safety instructions for the installation work	14
5.2	Installation overview Condair MD	15
5.3	Requirements for the installation room	16
5.4	Humidifier unit mounting	17
5.4.1	Instructions for positioning the humidifier unit	17
5.4.2	Insert the base panel and attach the adapters	20
5.4.3	Attach humidifier housing to ceiling or wall	21
5.5	Hydraulic unit mounting	25
5.5.1	Instructions for positioning the hydraulic unit	25
5.5.2	Hydraulic unit mounting	25
5.6	Create hose connections between hydraulic unit and humidifier unit	27
5.7	Installation of the fresh water supply and water drain	28
5.7.1	Fresh water supply	28
5.7.1.1	Fresh water supply requirements	28
5.7.1.2	When is a Condair RO-HS reverse osmosis system required?	29
5.7.1.3	Installation of fresh water supply	30
5.7.2	Water drain	31
5.8	Installing the heating water	32
5.9	Humidity control	34
5.10	Positioning and installation of the sensors	36
5.10.1	Positioning sensors	36
5.10.1.1	Installation of the humidity sensor as well as the high limit humidistat	37
5.10.1.2	Mounting the airflow monitor	37

5.11	Electrical installation	38
5.11.1	Notes on electrical installation	38
5.11.2	Condair MD wiring diagram	39
5.11.3	Connection work for external connections	40
5.11.3.1	Connection of the humidity sensor with humidity control via the integrated humidity controller	40
5.11.3.2	Connection of an external controller 0-10 V	41
5.11.3.3	Connection of the optional high limit humidistat in the supply air or extract air duct	41
5.11.3.4	Connection of the optional airflow monitor and the optional floor leak sensor	42
5.11.3.5	Connection of the leak sensor of the humidifier unit	42
5.11.3.6	Mains connection (mains socket)	43
5.11.4	Cable entry	43
6	Product specifications	44
6.1	Technical data of the hydraulic unit	44
6.2	Technical data of humidifier unit	45
7	Appendix	46
7.1	Dimensional drawing of humidifier unit	46
7.2	Dimensional drawings of adapters	46
7.3	Dimensional drawing of hydraulic unit	47

1 Introduction

1.1 First things first!

Thank you for choosing the **Condair MD**.

The Condair MD has been built using state-of-the-art technology and in accordance with the latest safety regulations. However, improper use of the Condair MD may put users and/or third parties at risk and/or may also cause damage to material assets.

Please observe and comply with all information and safety instructions in this documentation and in the instructions to the components built into the humidifier system to ensure safe, proper and cost-efficient operation of the Condair MD.

Should you have any questions after reading these instructions, please contact your local Condair partner. We will be happy to assist.

1.2 Notes on installation manual

Delimitations

The subject of this installation manual is the Condair MD. Options and accessories are only described insofar as is necessary for proper operation. Please see the relevant instructions for additional information on the options and accessories.

The information in this installation manual is restricted to the **installation** of the Condair MD and is aimed at **correspondingly trained specialist staff that has been adequately trained for the corresponding activity**.

This installation manual is supplemented by various separate documentation (operation manual, spare parts list, etc.), which are also included in the scope of delivery. Where necessary, this installation manual may refer to these publications.

Symbols used in this manual



CAUTION!

The signal word "CAUTION" together with the hazard symbol in a circle indicates information provided in this documentation which, if ignored, could lead to **damage and/or the failure of the device or other equipment**.



WARNING!

The signal word "WARNING", together with the general hazard symbol, indicates safety and hazard information given in this documentation which, if ignored, **could lead to injury to people**.



DANGER!

The signal word "DANGER", together with the general hazard symbol, indicates safety and hazard information given in this documentation which, if ignored, could lead to **serious injury or even death** to people.

Storage

Please keep this installation manual in a safe place where they can be accessed at all times. If the product changes owner, the installation manual must be handed over to the new operator.

If this installation manual are lost, please contact your Condair partner.

Language versions

This installation manual are available in various languages. For more information, please contact your Condair partner.

2 For your safety

General information

Any persons assigned to installing the Condair MD must have read and understood the installation manual as well as the operation manual of the Condair MD before starting work on the unit.

An understanding of the content of this installation manual and the operation manual is a basic prerequisite for protecting personnel from danger, avoiding improper installation and operating the device safely and properly.

All pictograms, signs and labelling applied to the Condair MD must be observed and kept in a clearly legible condition.

Personnel qualifications

All actions described in this installation manual may be performed by trained and adequately qualified specialist personnel authorised by the operator only.

Furthermore, for safety and warranty reasons, interventions may only be undertaken by specialist personnel authorised by Condair.

It is assumed that all persons entrusted to work on the Condair MD are familiar with and abide by the regulations on occupational health and safety and accident prevention.

Intended use

The Condair MD is **exclusively intended for duct air humidification together with Energy Recover Ventilation (ERV) within the specified operating conditions**. Any other use without the written permission of Condair is deemed to be improper use and can render the Condair MD hazardous. Any unintended use shall render guarantee claims void.

Intended use also includes the following: **observing all information contained in this documentation (particularly all safety and hazard warnings)**.

Danger that may arise from the device:



DANGER!
Risk of electrocution!

The hydraulic unit of the Condair MD operates using mains voltage. If the hydraulic unit is open, users may come into contact with live parts. Touching live parts may cause severe injury or death.

For this reason: Do not connect the Condair MD hydraulic unit to the power supply until all installation work has been completed, all installations have been checked for correct operation and the hydraulic unit has been correctly closed and locked again.

Avoidance of hazardous operating conditions

All persons entrusted to work on the Condair MD are obliged to report to the appropriate office or person representing the operator on any changes to the system that affect safety, and secure the Condair MD **against being switched on accidentally.**

Unauthorized modifications to the device

No additions or modifications must be made to the Condair MD without **the written permission of** Condair.

When replacing any defective components on the unit, use **only genuine accessories and spare parts** provided by your Condair partner.

3 Product overview

3.1 Model overview

The Condair MD consists of a hydraulic unit and a humidifier unit for installation in horizontal ventilation ducts and has a maximum humidification output of 2 kg/h. The humidification water is heated via the integrated heat exchanger, which is connected to the heating water system (35 ° C... 60 ° C) of a connected to a floor/wall-based heating system with a circulation pump or a convection circuit with a circulation pump.

Note: The stated humidification output is the maximum value, measured at an air throughput rate of 180 m³/h. The effective humidification output depends on the heating source output, the condition of the supply air and the adjusted humidity setpoint. The output has been verified by Fraunhofer Institute for Solar Energy Systems (ISE), Freiburg, Germany.

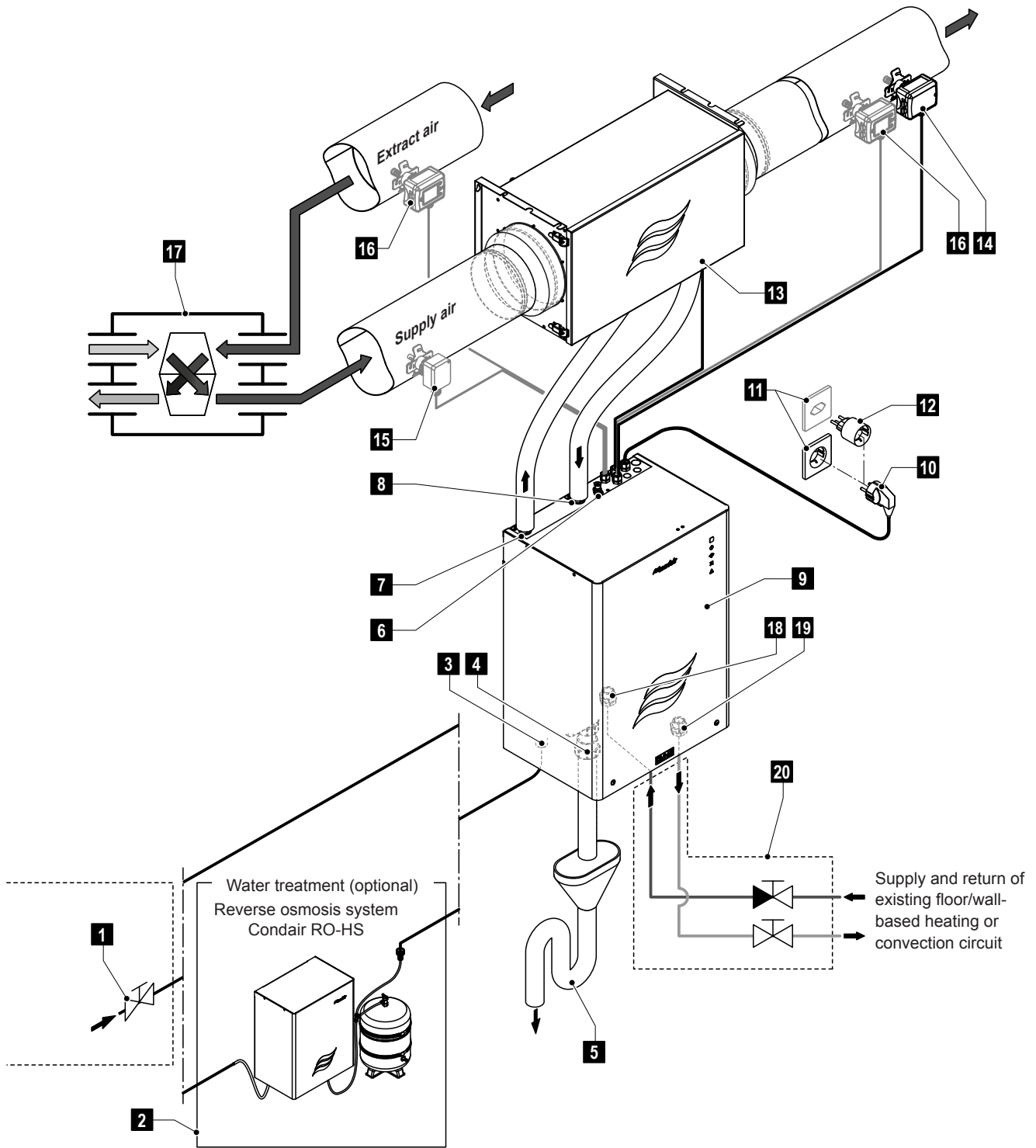
The functionality of the Condair MD can be enhanced using various options. Different accessories and consumables are also available.

3.2 Product labelling

The type plate features the product labelling:

	Type designation		Serial number (7 digits)		Production date, month/year
Connection voltage	Condair Group AG, Gwattstrasse 17, 8808 Pfäffikon SZ, Switzerland				
Maximum humidification output	Type: Condair MD	Serial no.: XXXXXXXX		11.19	
Permissible water connection pressure	Voltage: 230V/1~/50-60Hz	El. output: 1550 VA 6.7 A			
Field with test marks	Humidifier output: 2 kg/h	Water pressure: 1.5 to 5 bar, <30°C		Code: MD-EL-2HE	
Electrical output	CE				
Variant code	Engineered in Switzerland, made in Germany				

3.3 System overview Condair MD



- | | | | |
|----|-----------------------------------|----|---|
| 1 | Fresh water supply shut-off valve | 11 | Mains socket (230V/1~/50Hz) |
| 2 | Water treatment (optional) | 12 | Mains connection adapter CH |
| 3 | Fresh water supply connection | 13 | Humidifier unit |
| 4 | Drain connection | 14 | Humidity sensor with humidity limitation |
| 5 | Drain funnel with siphon | 15 | Air flow monitor |
| 6 | Service fluid connection | 16 | High limit humidistat supply or extract air duct (optional) |
| 7 | Humidifier unit supply | 17 | Energy recovery ventilation (ERV) |
| 8 | Humidifier unit return | 18 | Heating water supply connection |
| 9 | Hydraulic unit | 19 | Heating water return connection |
| 10 | Mains connection cable | 20 | On-site heating water installation |

Fig. 1: System overview Condair MD

3.4 Scope of delivery

Condair MD is supplied with:

Material	Scope of delivery Condair MD
Humidifier unit	
Humidifier housing 2 kg/h	x
Humidifier insert 2 kg/h	x
Adapters ventilation duct incl. seals	x
Screws and wall plugs for wall installation	x
Hydraulic unit	
Hydraulic unit 2 kg/h with power cable and $\varnothing 40/\varnothing 32$ mm reduction screw connection for water drain connection	x
Control Components	
Humidity sensor for duct installation incl. connecting cable	x
Connecting cable leakage sensor humidifier unit	x
Installation set	
"Large" installation set (all necessary hoses, insulation hoses, hose connectors, etc.) for establishing the hydraulic connections between the hydraulic unit and humidifier unit	x

3.5 Options

The following options are available for Condair MD:

Option	Description
Air flow monitor	Air flow monitor with connection cable for duct installation for monitoring the air flow in the supply air duct (see also humidity control in Section 5.9).
High limit humidistat	High limit humidistat with connection cable for duct installation for monitoring the maximum humidity in the supply air duct or in the extract air duct (see also humidity control in Section 5.9).
Leakage monitoring room	Leakage monitoring for rooms without floor drain consisting of floor sensor and connection cable.
Filter humidifier unit	Air filter for installation in the humidifier unit.
Condair RO-HS reverse osmosis system	External reverse osmosis system for supplying reverse osmosis water to the Condair MD.

3.6 Accessories

The following accessories are available for the Condair MD:

Accessories	Description
Adapters ventilation duct	Adapters for humidifier unit incl. seal. The adapters are available with different connection diameters: DN125, DN160 or DN180.
Service kit	Service kit for descaling/disinfection of Condair MD. The service kit includes: A dosing bottle with quick coupling, a funnel, a container with descaler granules and a bottle with 1 l disinfectant.

4 Checking delivery/storage and transport

4.1 Checking delivery

Following receipt of the delivery:

- Check the packaging for damage.
Any damage must be immediately reported to the transport company.
- Use the delivery note to check whether all components have been delivered.
Report missing components to your Condair partner within 48 hours. Condair Group AG assumes no responsibility for missing material beyond this period.
- Remove the components from their packaging and check them for any damage. Notify the transport company immediately should you find any damaged parts/components.



WARNING!

For hygiene reasons, the humidifier insert packaging may only be opened before the humidifier insert is installed.

- Check, according to the device data on the type plate, whether the supplied components are suitable for installation at the installation location.

4.2 Storage and transport

Storage

The Condair MD components must be stored in the original packaging in a place secured against dripping water under the following conditions until installation:

- Room temperature: 5 to 40°C
- Room humidity: 10 to 75% RH (non-condensing)

Transport

Where possible, always transport the device and components in the original packaging and use a suitable means of transport or suitable lifting device.



WARNING!

The customer is responsible for ensuring that staff are trained on handling heavy goods and are aware of and adhere to the relevant provisions on occupational safety and accident prevention.

Packaging

If the packaging should be disposed of, follow local environmental protection guidelines. Recycle the packaging material wherever possible.

5 Installation overview

5.1 Safety instructions for the installation work

Personnel qualifications

All installation work may be carried out by qualified, trained personnel only. It is the responsibility of the operator to check the qualifications.

General information

All information in this installation manual for installation of the device as well as for water and electrical installation must be observed and complied with.

All local regulations for the installation of the water and electrical systems must be observed and adhered to.

Safety

For some of the installation work, the cover of the hydraulic unit must be removed. It is therefore essential to note the following:



DANGER!
Risk of electrocution!

The hydraulic unit of the Condair MD operates using mains voltage. If the hydraulic unit is open, users may come into contact with live parts. Touching live parts may cause severe injury or death.

For this reason: Do not connect the hydraulic unit to the mains until all installation work has been completed, all installations have been checked for correct operation and the hydraulic unit has been correctly closed and locked again.



CAUTION!

Electronic components on the inside of the Condair MD hydraulic unit are very sensitive to electrostatic discharge.

For this reason: To protect the electronic components, measures must be taken against damage due to electrostatic discharge (ESD protection) when the hydraulic unit is open for installation work.

5.2 Installation overview Condair MD

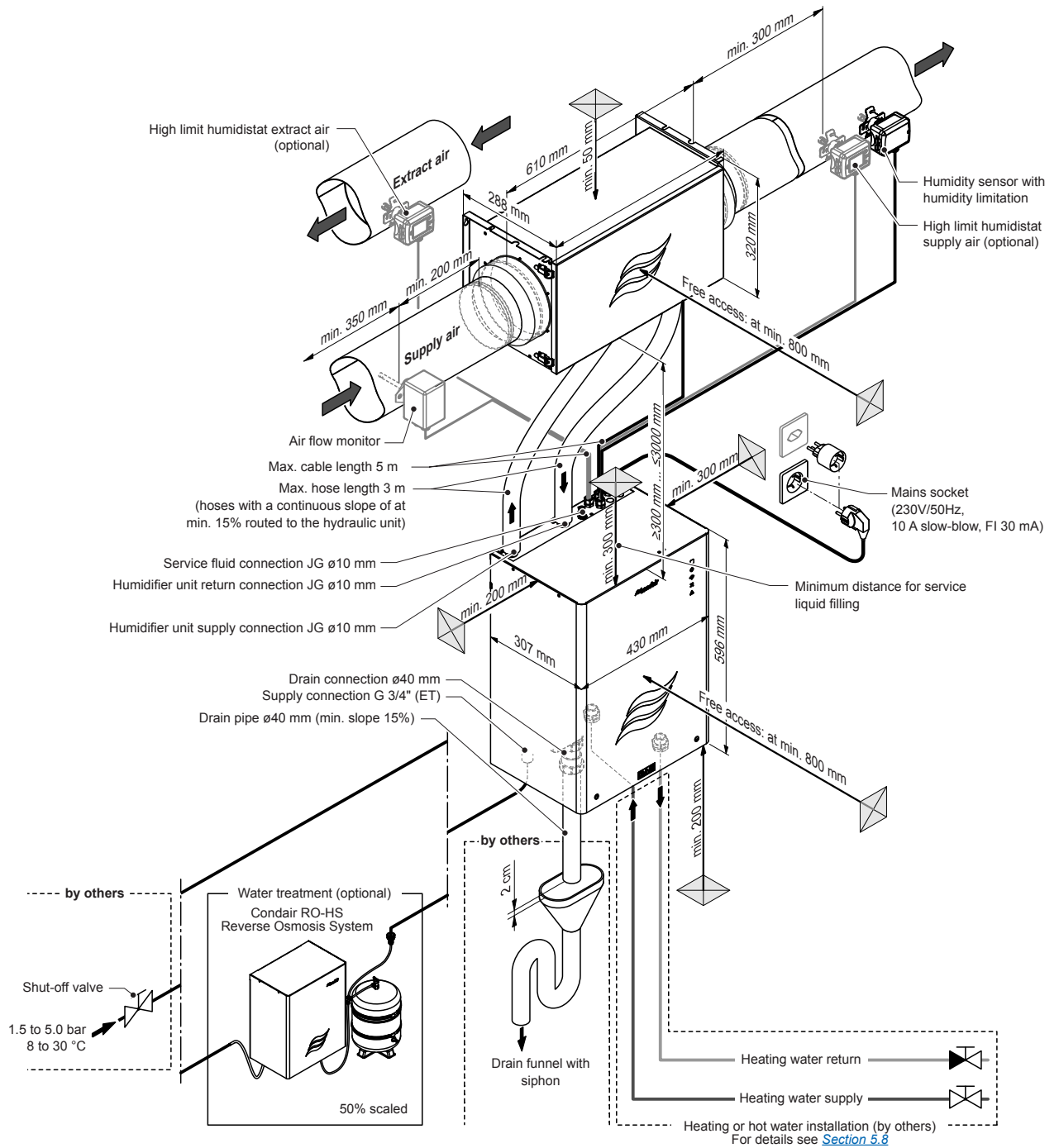


Fig. 2: Installation overview Condair MD

5.3 Requirements for the installation room

The humidifier unit and the hydraulic unit have been designed for installation in protected indoor spaces. Please note the following regarding the requirements for the installation site:

- The humidifier unit must be installed together with the hydraulic unit in a utility room that has been protected against unauthorized access.
- The installation room must have a **floor drain** connected to the on-site wastewater pipe.
Note: If there is no floor drain, the installation of the optional "leakage monitoring" is recommended.
- The room temperature must be between +7°C and +30°C all year round and the humidity between 15% rH and 50% rH (non-condensing) and the room must be ventilated.
- There must be a sufficiently large, free ceiling or wall surface at the installation location for mounting the humidifier unit and a sufficiently large, free wall surface for mounting the hydraulic unit.

5.4 Humidifier unit mounting

5.4.1 Instructions for positioning the humidifier unit

Note: When positioning the humidifier unit in the air duct, the air flow direction need not be taken into account!

Please observe and follow the instructions for positioning the humidifier unit:

- The ceiling/wall on which the humidifier unit or the hydraulic unit is mounted must have sufficient load-bearing capacity and be suitable for fastening (see [Fig. 3](#), [Fig. 4](#) and [Fig. 5](#)).

Ceiling mounting with threaded rods

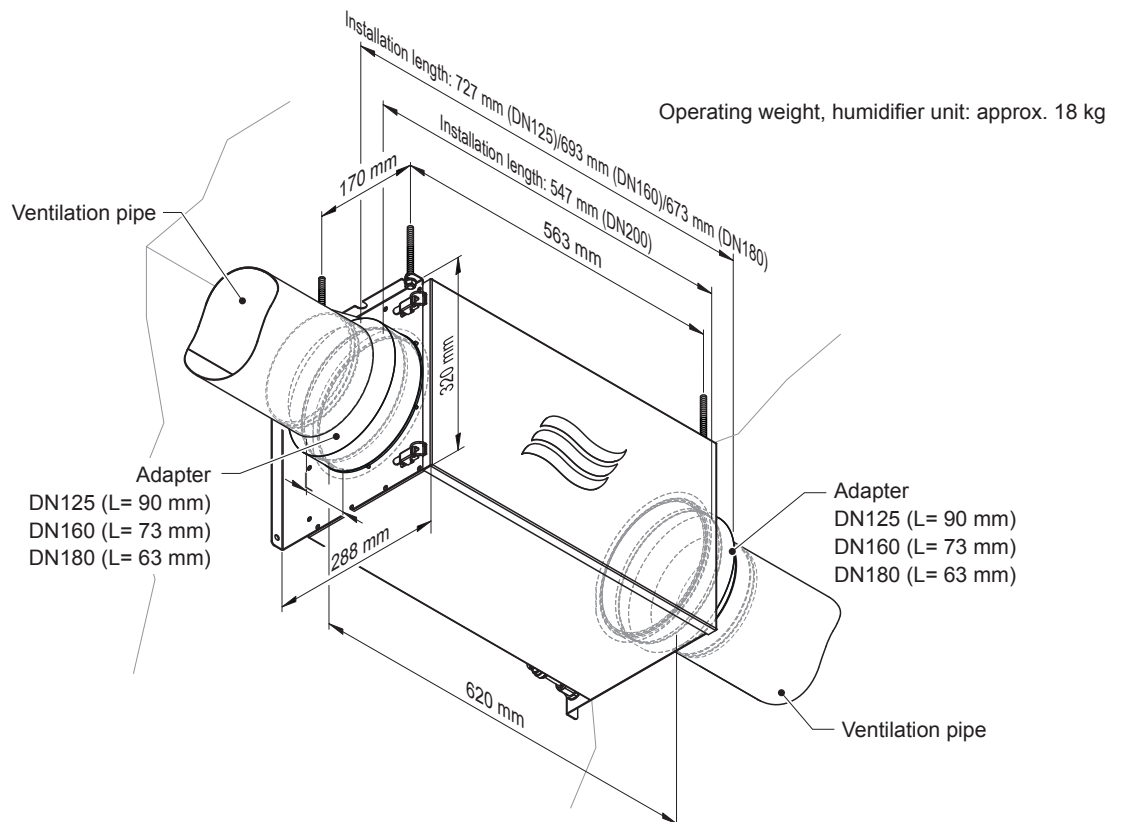


Fig. 3: Dimensions ceiling mounting with threaded rods

Alternative ceiling mounting with pipe clamps

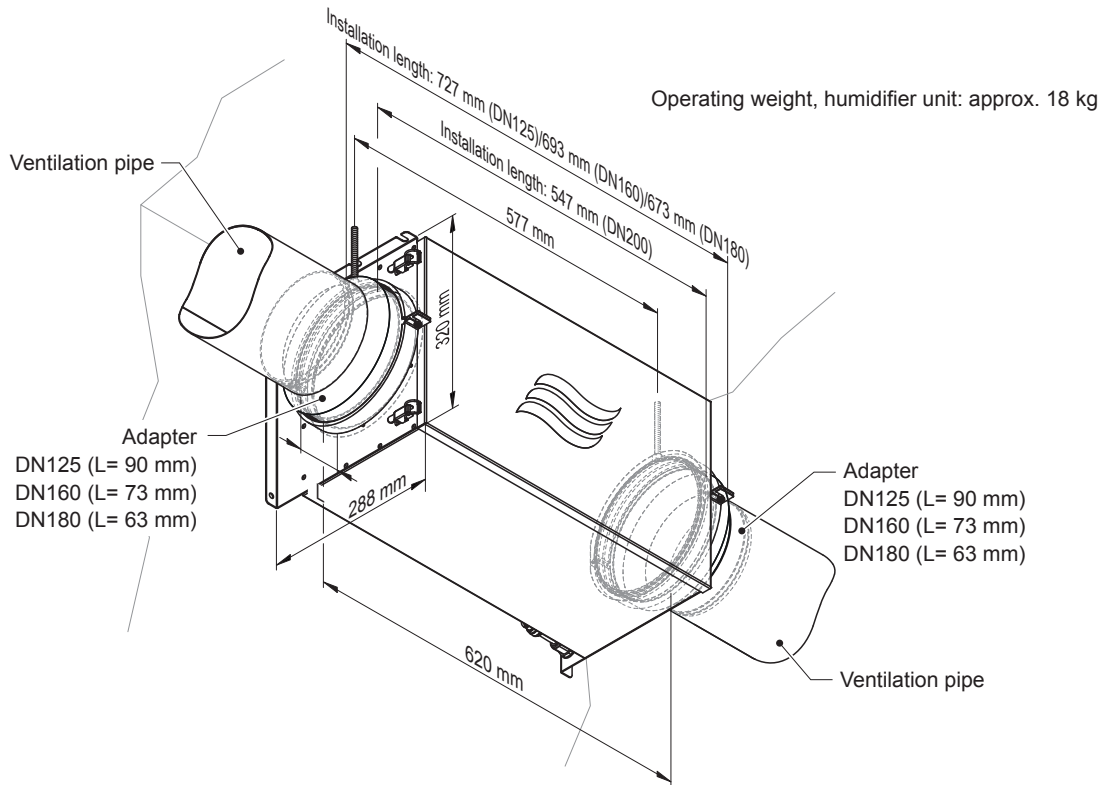


Fig. 4: Dimensions ceiling mounting with pipe clamps

Wall mounting

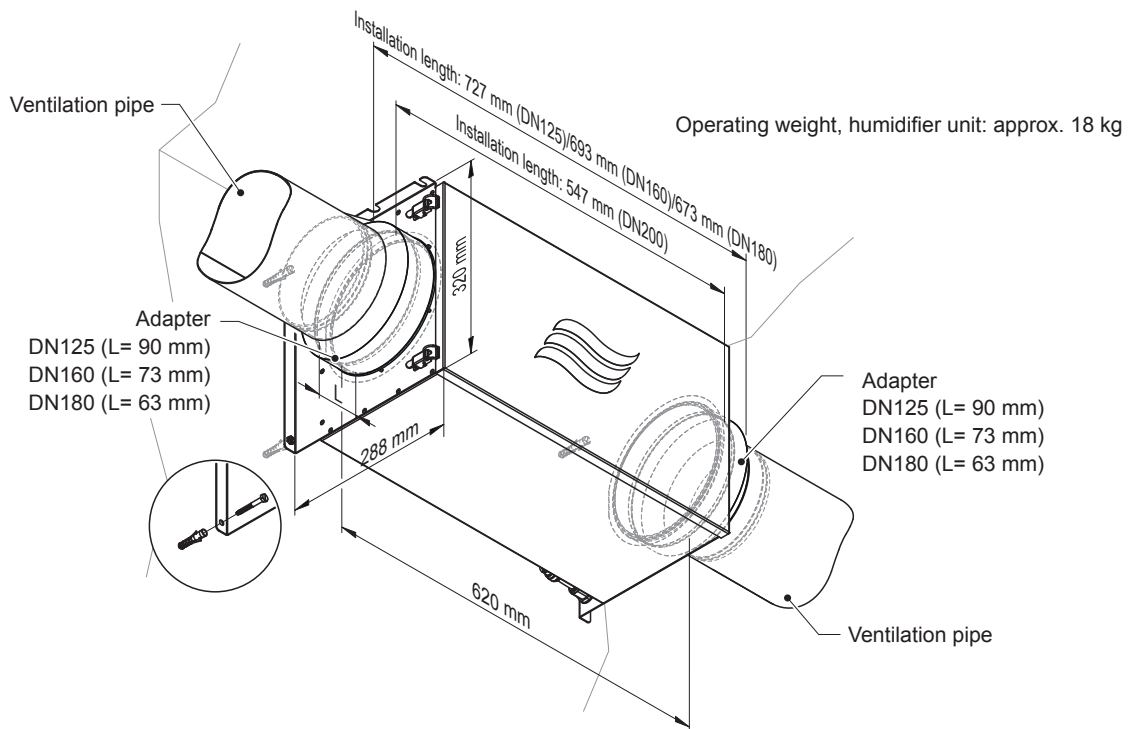


Fig. 5: Dimensions wall mounting

- The installation site must not be exposed to direct sunlight and must be sufficiently far away from other heat sources.
- The humidifier unit must be installed at minimum 0.3 m and at maximum 3.0 m above the hydraulic unit in the supply air duct of the ERV. The pipe lengths between the humidifier unit and the hydraulic unit must not exceed 3 m. In order to avoid standing water in the pipes, it must be taken into account that the pipes between the humidifier unit and the hydraulic unit must be routed with **a constant slope**.
- A filter with at least ISO Coarse 80% class (recommended: ISO ePM1 60%) must be installed in the supply air of the ERV and regularly serviced to ensure hygienic operation. This filter reliably protects the humidifier insert from contamination by dust particles and thus extends the service life of the humidifier insert.
- Position the humidifier unit in such a way that it is easily accessible and has sufficient space for servicing. Minimum distances according to the installation overviews in [Section 5.2](#) must be observed.
- The humidifier unit is installed with the enclosed adapters in the central supply air line upstream of the distributor and downstream of any silencer.

Ceiling mounting with threaded rods: The humidifier unit is fastened to the ceiling with four threaded rods and nuts (see [Fig. 3](#)). The fastening material is not included in the scope of delivery.

Alternative ceiling mounting with pipe clamps: The humidifier unit is fastened to the ceiling with two $\varnothing 200$ mm pipe clamps (see [Fig. 4](#)). The fastening material is not included in the scope of delivery.

Wall mounting: The humidifier unit is attached to the wall with 4 dowel pins and screws (enclosed) (see [Fig. 5](#)).

The **total installation length** is:

- | | |
|------------------------------|---------------|
| – When using DN125 adapters: | 727 mm |
| – When using DN160 adapters: | 693 mm |
| – When using DN180 adapters: | 673 mm |
| – Without adapters (DN200): | 547 mm |

- The ceiling or wall on which the humidifier unit is mounted must have sufficient load-bearing capacity as well as stability and be suitable for fastening. The operating weight of the humidifier unit is approx. 18 kg.
- To ensure correct operation of the air flow monitor and the high limit humidistat, a straight duct section with a minimum length of 550 mm must be provided upstream of the humidifier unit and a straight duct section with a minimum length of 300 mm downstream of the humidifier unit must be provided for the integration of the air flow monitor and the high limit humidistat.

5.4.2 Insert the base panel and attach the adapters

1. Disengage the snap fasteners and remove the humidifier housing cover.
2. Clean humidifier housing, base panel and adapters.
3. Insert the base panel into the humidifier housing.
4. Slide the adapters on both sides onto the connection nozzle as far as they will go.
5. Attach the humidifier housing cover and fasten with the snap fasteners.

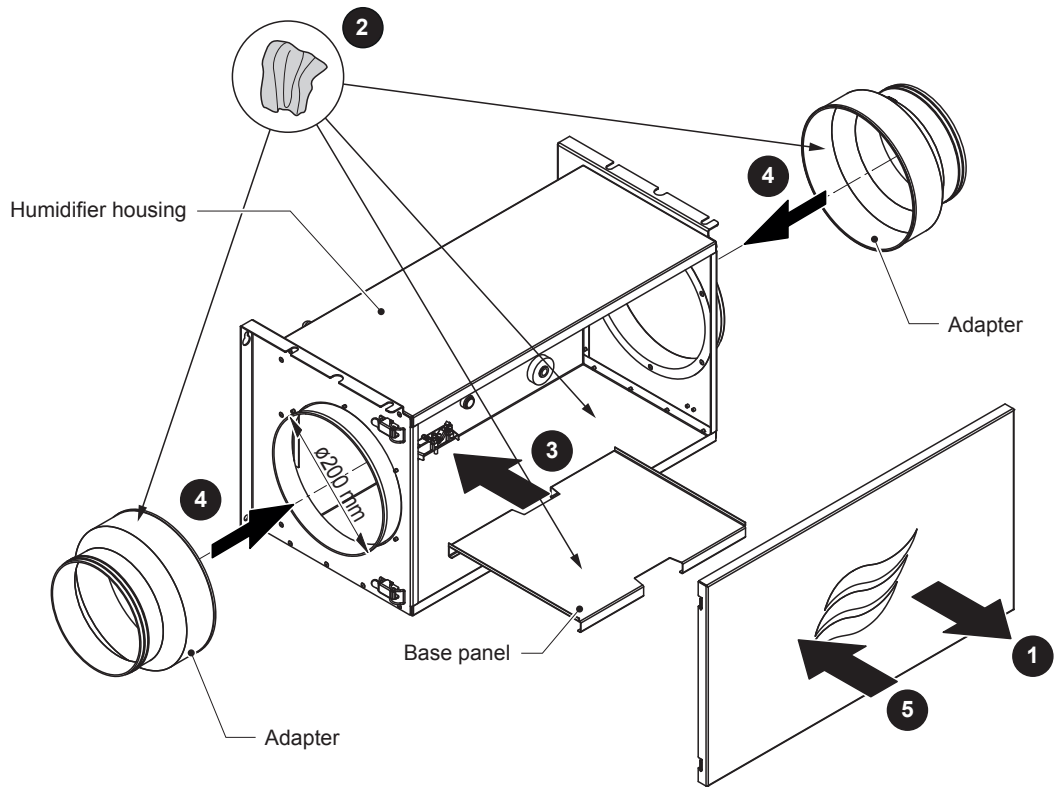


Fig. 6: Insert the base panel and attach the adapters

5.4.3 Attach humidifier housing to ceiling or wall

Ceiling mounting with threaded rods

1. Make the fastening points "A" (M8 internal thread) for the threaded rods in the designated place on the ceiling. Screw threaded rods into the fastening points.

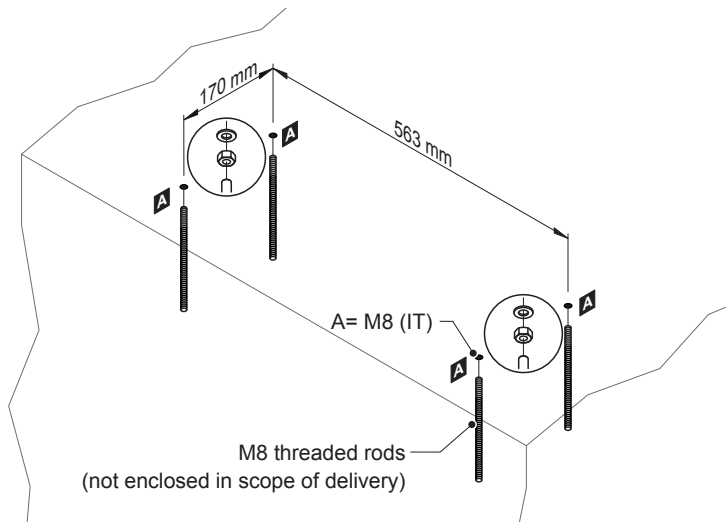


Fig. 7: Create fastening points and mount threaded rods

2. Attach the humidifier housing to the threaded rods using the mounting brackets of the housing with the M8 nuts and washers as shown in [Fig. 8](#).

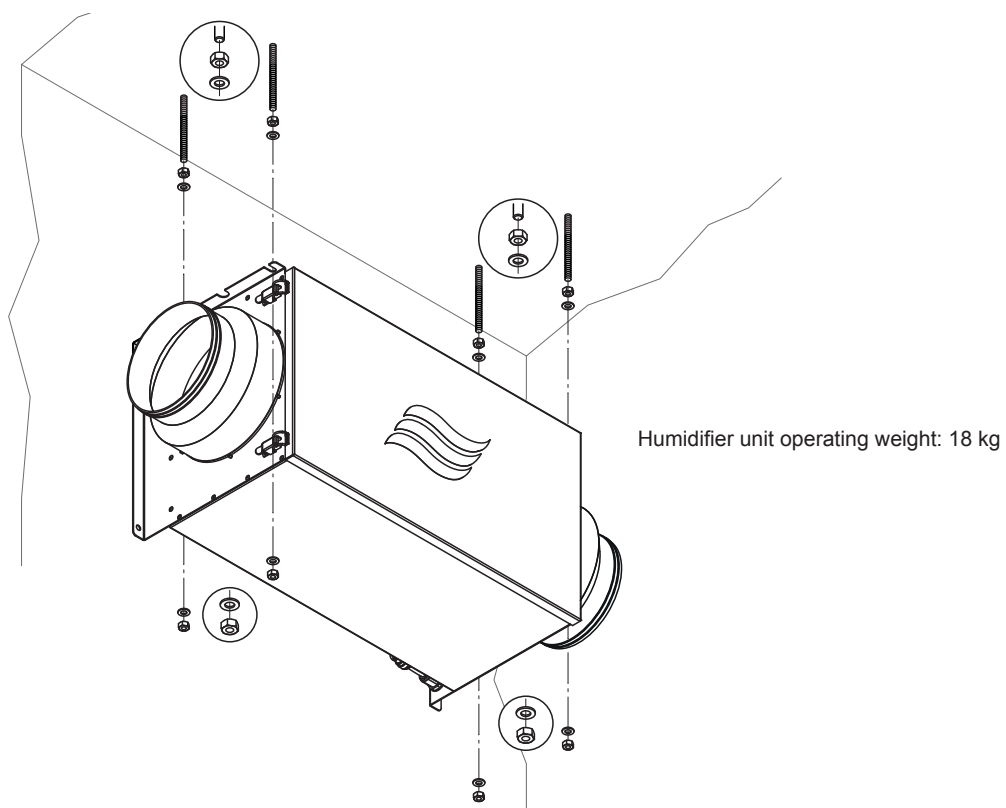


Fig. 8: Attach the humidifier housing to the threaded rods

- Using a spirit level, align the humidifier housing horizontally in both directions and tighten the nuts on the mounting bracket against each other.

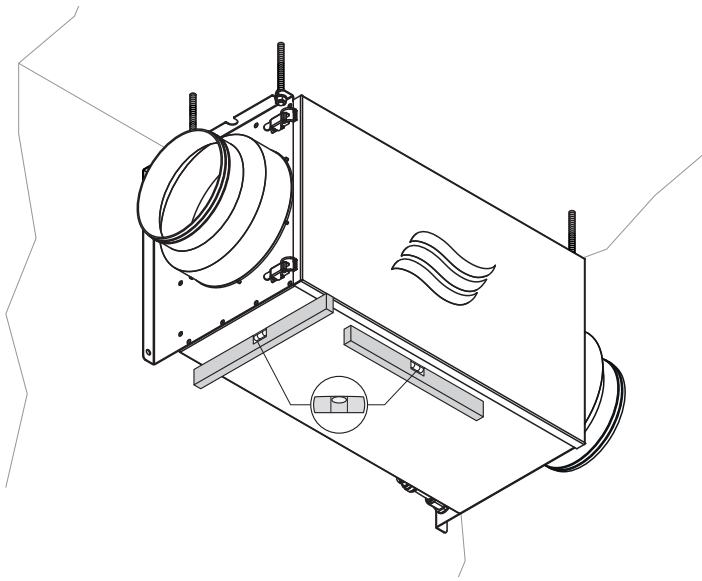


Fig. 9: Align humidifier housing and tighten screw connections

- Clean the ventilation pipes and slide onto the adapters as far as they will go.

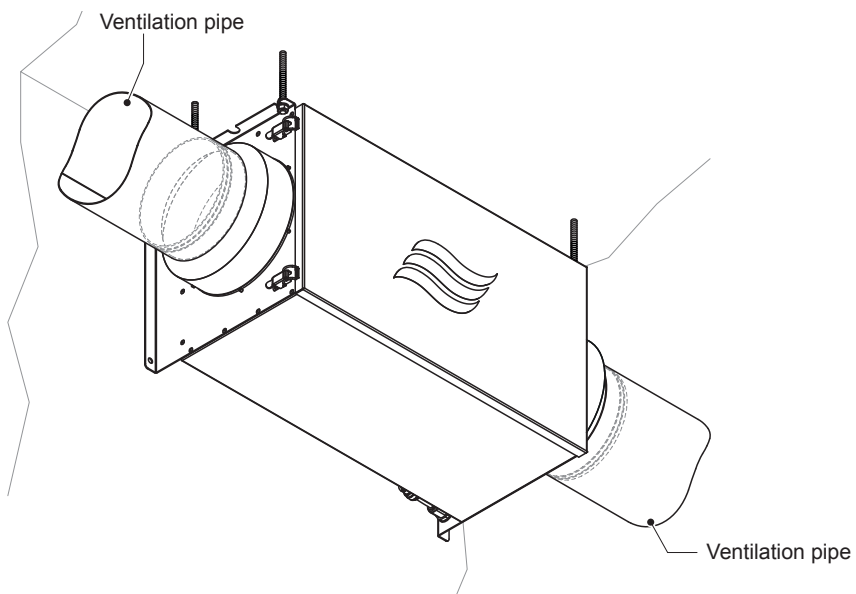


Fig. 10: Mounting the ventilation pipes

Ceiling mounting with $\varnothing 200$ mm pipe clamps

1. Make the fastening points "A" (M8 internal thread) for the threaded rods of the pipe clamps in the designated place on the ceiling. Screw threaded rods into the fastening points.

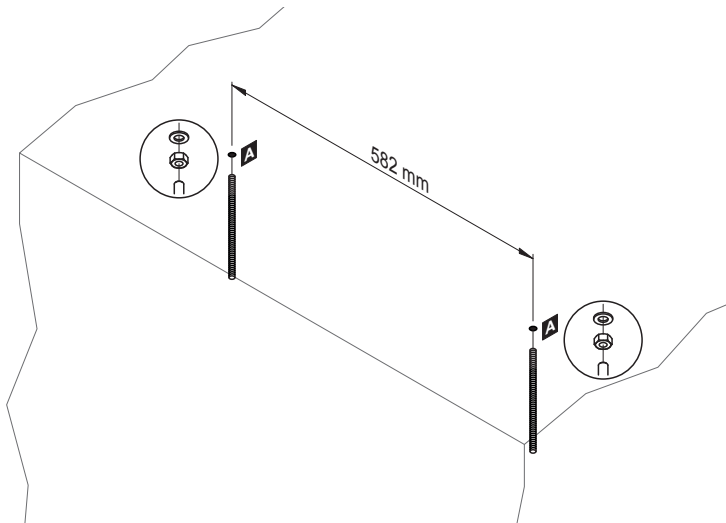


Fig. 11: Create fastening points and mount threaded rods

2. Attach $\varnothing 200$ mm pipe clamps to the threaded rods and align horizontally using a spirit level.
3. Attach the humidifier housing to the pipe clamps (see [Fig. 12](#)).
Note: For DN200 ventilation pipes, the ventilation pipes must be slid onto the connections on the humidifier housing (step 4) before the humidifier housing is fastened to the pipe clamps.

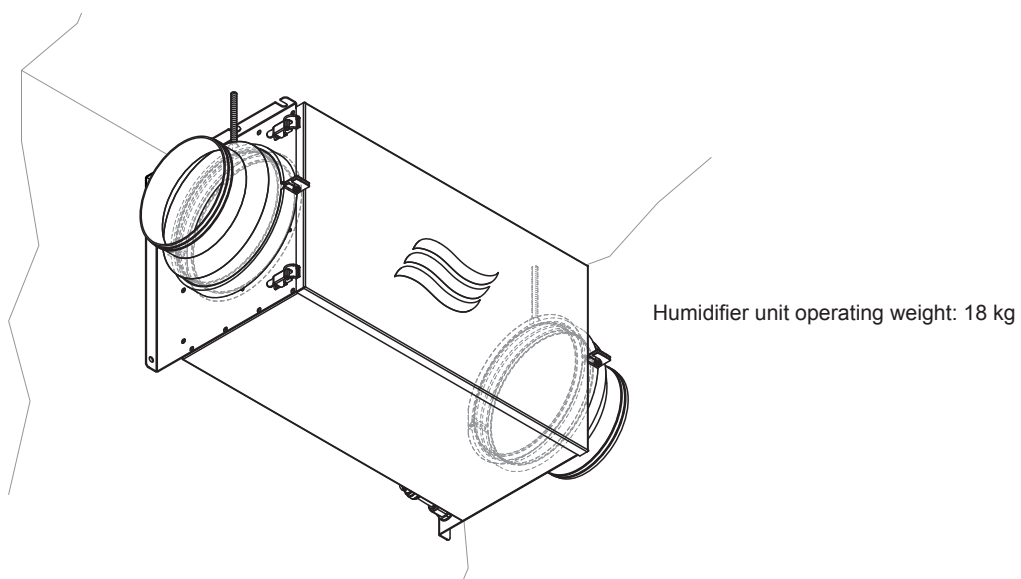


Fig. 12: Attach the humidifier housing to the pipe clamps

4. Clean the ventilation pipes and slide onto the adapters as far as they will go.

Wall mounting

1. Mark the fixing points "A" for the two wall brackets at the intended place with a spirit level and drill 60 mm into the wall with a diameter of $\text{\O}10$ mm.

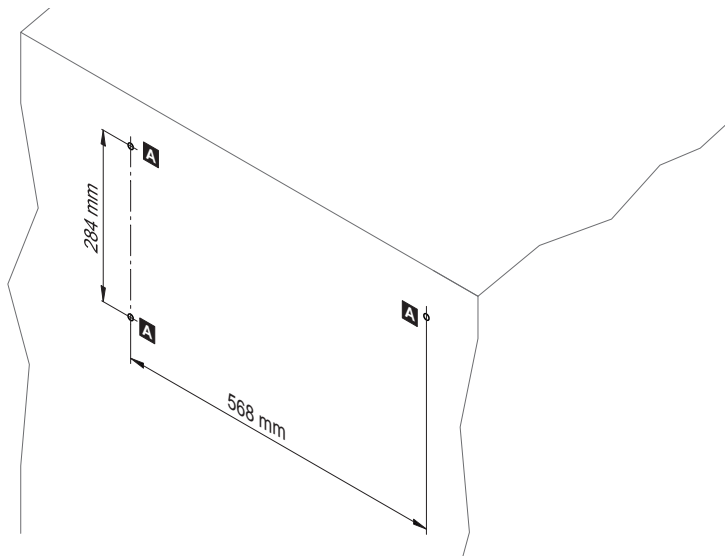


Fig. 13: Create fastening points

2. Fasten the humidifier housing to the wall, wooden panel, etc., either with the enclosed dowels, washers and screws or with other suitable fastening material.

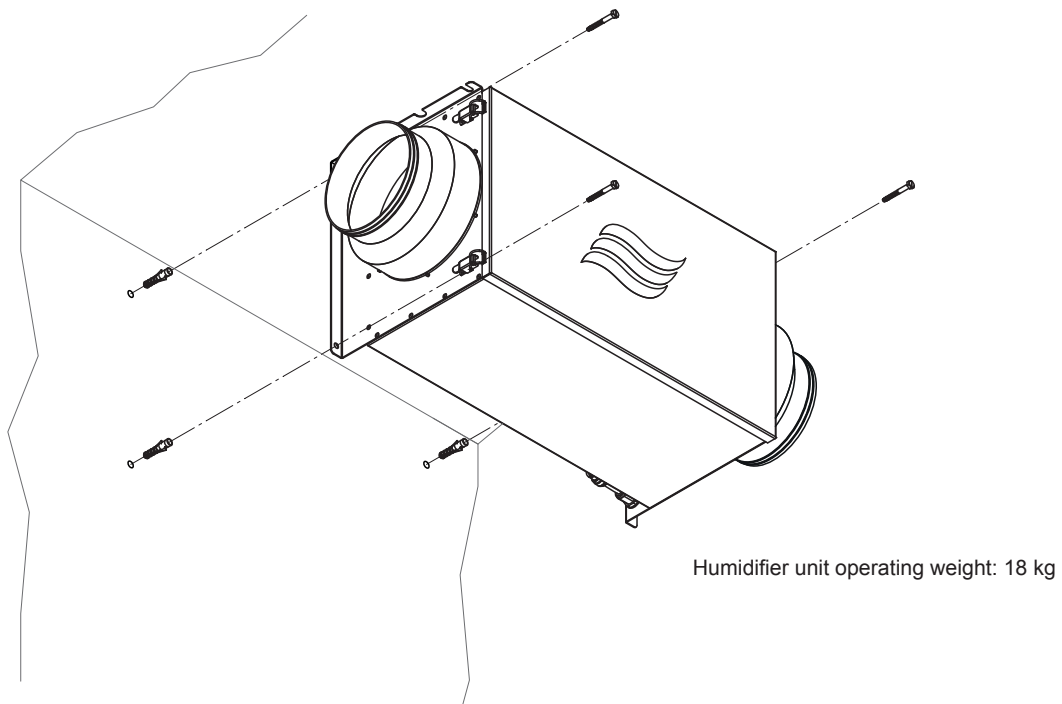


Fig. 14: Attach the humidifier housing to the wall

3. Using a spirit level, align the humidifier housing horizontally and tighten the screws.
4. Clean the ventilation pipes and slide onto the adapters as far as they will go.

5.5 Hydraulic unit mounting

5.5.1 Instructions for positioning the hydraulic unit

Please observe and follow the instructions for positioning the hydraulic unit:

- The installation site must not be exposed to direct sunlight and must be sufficiently far away from other heat sources.
- The hydraulic unit must be mounted at minimum 0.3 m and at maximum 3.0 m below the humidifier unit. The pipe lengths between the humidifier unit and the hydraulic unit must not exceed 3 m. In order to avoid standing water in the pipes, it must be taken into account that the pipes between the humidifier unit and the hydraulic unit must be routed with **a constant slope**.
- The construction (wall, column, floor-mounted bracket, etc.) to which the hydraulic unit is to be mounted must have sufficient load-bearing capacity and stability and be suitable for mounting. The operating weight of the hydraulic unit is approx. 19 kg.
- Position the hydraulic unit in such a way that it is easily accessible and has sufficient space for servicing. Minimum distances according to the installation overview in [Section 5.2](#) must be observed.
- Make sure that the hydraulic unit at the installation site is protected from dripping water and that the permissible ambient conditions are observed.
- Do not attach the hydraulic unit to hot or very cold walls or vibrating components.
- Use the fastening material enclosed in the scope of delivery for fastening the hydraulic unit only.

5.5.2 Hydraulic unit mounting

1. Mark the fixing points "A" for both wall brackets at the intended place with a spirit level and drill 60 mm into the wall with a diameter of Ø10 mm.
Important: The fastening point (wall, wooden panel, etc.) must have sufficient load-bearing capacity and stability and be suitable for attachment!
2. Fasten the wall brackets to the wall, wooden panel, etc., either with the enclosed dowels, washers and screws or with other suitable fastening material. Before tightening the fastening material, align the wall brackets horizontally using a spirit level.
3. Turn the locking tabs outwards on both sides of the hydraulic unit (open position, see [Detail "B"](#) in [Fig. 15](#)).
4. Hook the hydraulic unit into the wall brackets. Then turn the two locking tabs on the rear panel of the hydraulic unit inwards (closed position, see [Detail "C"](#) in [Fig. 15](#)) to secure the hydraulic unit to the top wall bracket.

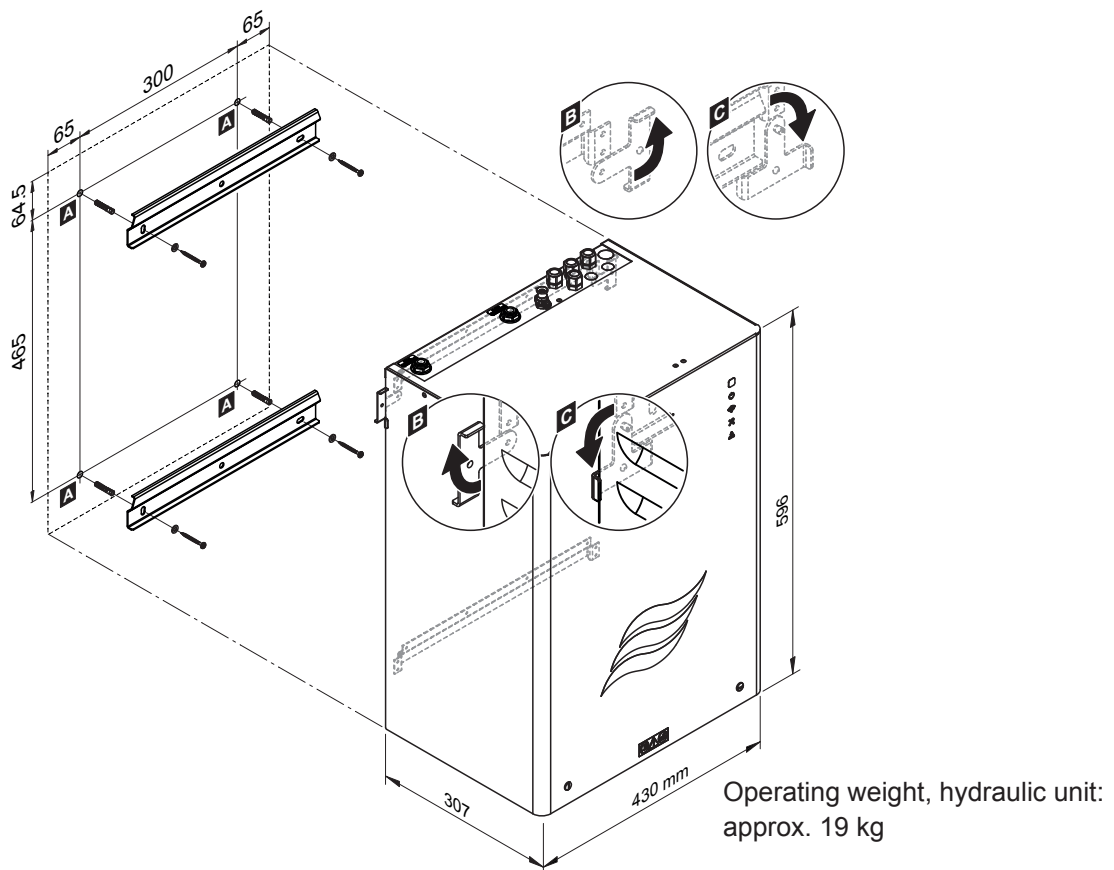


Fig. 15: Installation of the hydraulic unit (dimensions in mm)

5. **Important! After installing the hydraulic unit, the red safety straps securing the water tank and pump for transport must be removed:**

- Undo the two screws of the housing cover and remove the housing cover.
- Cut and remove the red safety straps around the water tank and the pump.
- Refit the housing cover and secure with the two screws.

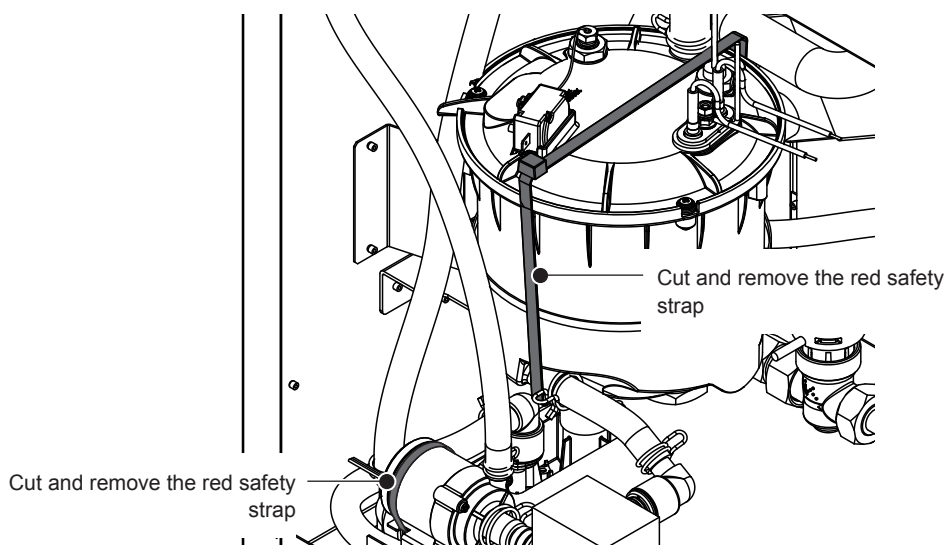


Fig. 16: Remove the securing strap (transport lock)

5.6 Create hose connections between hydraulic unit and humidifier unit

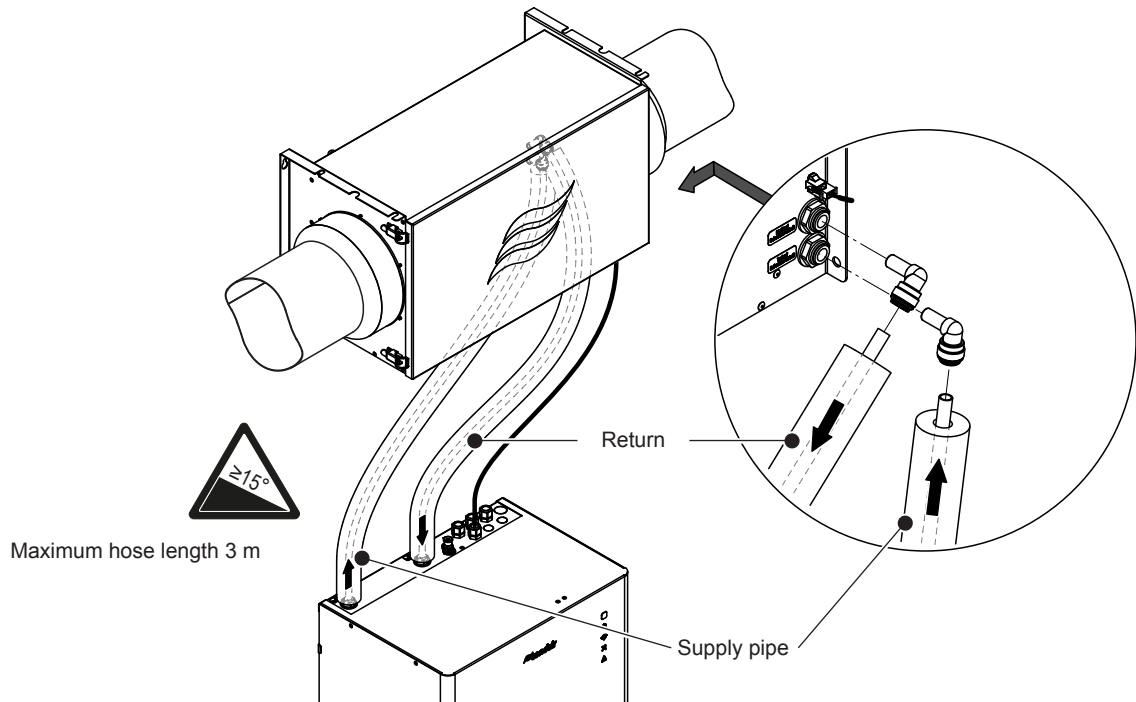


Fig. 17: Hose connections

1. Remove the yellow plastic plugs from the connections on the hydraulic unit and the humidifier unit.
2. Cut the supply and return hoses and the insulation hoses to the required length (material enclosed in scope of delivery). Then slide the insulation hoses onto the supply and return hoses.
3. Connect the supply and return hoses to the corresponding connections of the hydraulic unit and the humidifier unit according to [Fig. 17](#). If necessary, use the enclosed angled connectors.

Comply with the following:

- Only use the supplied installation material ($\varnothing 10$ mm hose, elbow connector and insulation hoses) to create the humidifier supply and return pipes.
- Only use a hose cutter to cut the hoses. Only a hose cutter guarantees a straight and kink-free cut and thus operation without leaks.
- The maximum permissible hose length is 3 m for both the supply and return pipe.
- The pipes must be routed with a constant slope of at minimum 15% to the hydraulic unit.
- Insulate the hoses with the enclosed insulation hoses. For this purpose, slip the insulation hoses over the hoses.
- Push the hoses into the connectors as far as they will go. Check: Subsequently pull on the hose. A correctly installed hose can no longer be disconnected without pressing on the circlip. To loosen the connections, press in the circlip on the connector (use the special wrench that has been enclosed, if necessary) and pull out the hose/angled plug connector.

5.7 Installation of the fresh water supply and water drain

5.7.1 Fresh water supply

5.7.1.1 Fresh water supply requirements

The fresh water (raw water) must meet the following requirements:

	Min. Value	Max. Value	Notes
Permissible water hardness Permissible pH value	1°dH/1.8°FH) 6.5	30°dH/53.7°FH) 9.0	The water hardness (or conductivity) of the supply water must be determined before commissioning, either by measuring the water hardness or by obtaining information from the local water supplier. Note: Please refer to the chart in Section 5.7.1.2 to determine when to use a reverse osmosis system Condair RO-HS.
Permissible water pressure (without water treatment RO-HS)	1.5 bar	5 bar	If the water pressure is >5 bar, a pressure reduction valve (set to 4.0 bar) must be installed in the fresh water supply. For connection pressures <1.5 bar, please contact your Condair partner.
Permissible water pressure (with water treatment RO-HS)	0.5 bar	3.5 bar	If the water pressure is >3.5 bar, a pressure reduction valve (set to 3.5 bar) must be installed in the fresh water supply. For connection pressures <0.5 bar, please contact your Condair partner.
Permissible supply water temperature	8°C	30 °C	—
Water quality	Drinking water		Regulations according to DVGW/SVGW and local regulations for the hygiene of drinking water must be complied with.

Note: The water hardness and pH value parameters can be obtained from your water supplier or taken from the designated water analysis (usually available on the website of the water supply company).

Note: If the Condair MD is to be supplied with water from a potentially existing water treatment device, please contact your Condair representative beforehand.



CAUTION!

The Condair MD must not be supplied with softened water. If a water softener has been installed in the water supply, the water supply to the Condair MD must either be connected upstream of the water softener or the Condair RO-HS reverse osmosis system must be installed downstream of the water softener.

5.7.1.2 When is a Condair RO-HS reverse osmosis system required?

The Condair MD can be operated with raw water (drinking water) as long as the water hardness or the pH value of the water do not exceed a certain limit values. If these limit values are exceeded, the optional reverse osmosis system Condair RO-HS must be used.

The following chart shows the limit values for water hardness and pH value from which a RO-HS reverse osmosis system is required.

°dH/ph	6.50	6.75	7.00	7.25	7.50	7.75	8.00	8.25	8.50	8.75	9.00
3.0											
3.5											
4.0											
4.5											
5.0											
5.5											
6.0											
6.5											
7.0											
7.5											
8.0											
8.5											
9.0											
9.5											
10.0											
10.5											
11.0											
11.5											
12.0											
12.5											
13.0											
13.5											
14.0											
14.5											
15.0											
15.5											
16.0											
16.5											
17.0											
17.5											
18.0											
18.5											
19.0											
19.5											
20.0											

1
No reverse osmosis system
RO-HS required!
Descaling every 3 months of
operation required

2
Reverse osmosis
system RO-HS required

3
Reverse osmosis system
RO-HS with upstream water
softener required!

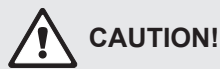
- 1) The Condair MD can be operated with raw water (drinking water) according to the specifications in [Section 5.7.1.1](#). The RO-HS reverse osmosis system can, but does not have to be used. However, the Condair MD must not be operated with softened water.
- 2) The RO-HS reverse osmosis system is required to operate the Condair MD. An on-site water softening system can, but does not have to be, installed upstream of the RO-HS reverse osmosis system.
- 3) The RO-HS reverse osmosis system is required to operate the Condair MD. An on-site water softening system must be installed upstream of the RO-HS reverse osmosis system.

5.7.1.3 Installation of fresh water supply

The fresh water supply must be established in accordance with [Fig. 18](#) and comply with the DVGW/ SVGW guidelines and the applicable local regulations for drinking water installations. The connection information stated must be complied with.

Note: If the Condair MD is supplied via an upstream water treatment device, please observe the instructions in the separate instructions for the corresponding water treatment device.

Important! Prior to connection to the hydraulic unit or water treatment device, the fresh water supply pipe must be thoroughly flushed.



The connection thread on the hydraulic unit is made of plastic. To prevent overtightening of the thread, only tighten the union nut of the connection hose by hand.

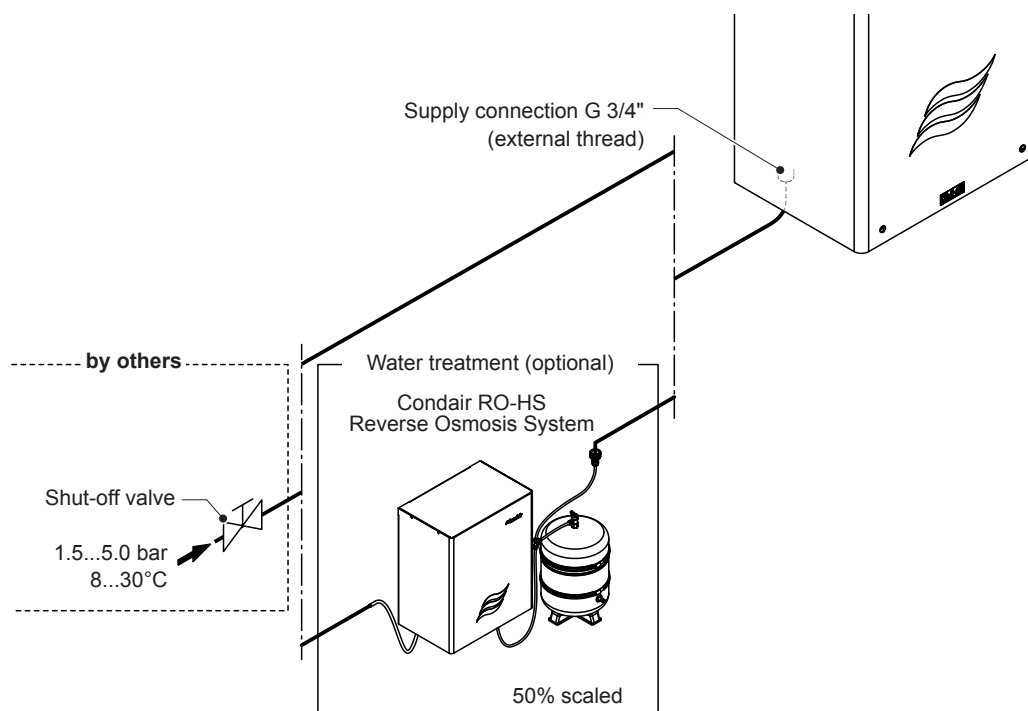


Fig. 18: Installation of fresh water supply

- If possible, the **shut-off valve** (by others) must be installed in the immediate vicinity of the hydraulic unit or water treatment device.
- It is recommended to route a rigid pipe close to the hydraulic unit or water treatment device. The connection to the hydraulic unit is established using a corresponding armored hose (on-site, approved for drinking water) or using the installation material included in the scope of delivery of the water treatment device.
- The connection material used must be pressure-tested and permitted for use in drinking water supply networks.

5.7.2 Water drain

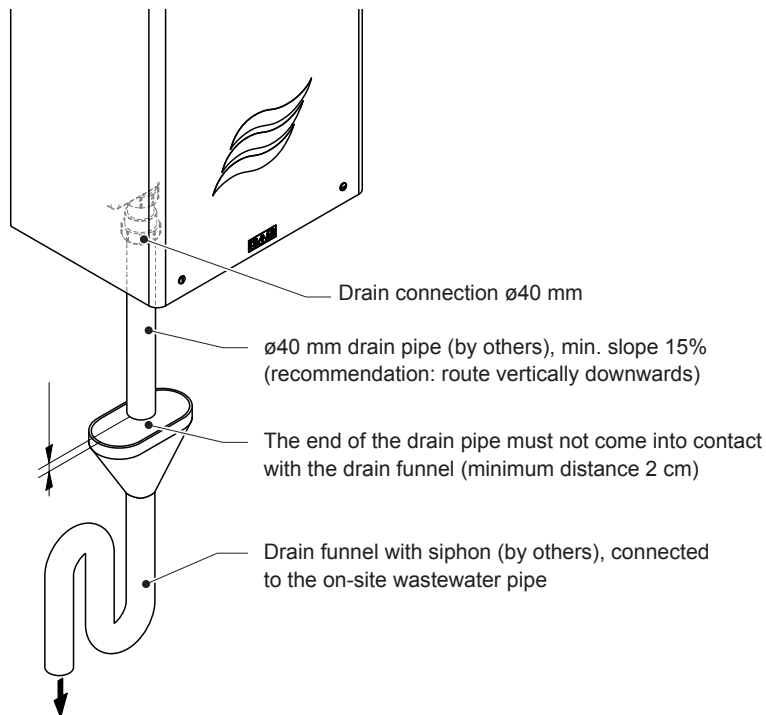


Fig. 19: Water drain

Set up the water drain in accordance with the overview illustration and the applicable specifications for waste water installations. The connection information stated must be complied with.

- Ensure that the outlet pipe, drain funnel and siphon are easily accessible and have been correctly attached for monitoring and cleaning purposes.
- The drain funnel, siphon and on-site drain pipe must be dimensioned in such a way that drainage is guaranteed when the system is completely emptied. When the system is completely bled, 8 l of water is blown off within approx. 5 minutes.
- Route the drain pipe downwards to the drain funnel with a constant slope (min. 15%, recommendation: vertical).
- Secure the drain pipe so that it cannot slip out of the drain funnel during operation.
- The end of the drain pipe must not come into contact with the drain funnel (minimum distance 2 cm).
- If the on-site wastewater pipe is routed above the wastewater connection of the hydraulic unit, the water must be transported to the required height with an upward pumping system. If no upward pumping system is available, it must be installed on site.

5.8 Installing the heating water

With the Condair MD, the hot water from an underfloor/wall heating or a convector circuit is used to heat the circulating water in the Condair MD. For this purpose, a heating water supply pipe and a heating water return pipe must be connected to the hydraulic unit in accordance with [Fig. 20](#) and the applicable local regulations for heating systems.

This connection variant requires an existing on-site underfloor or radiator heating pump.

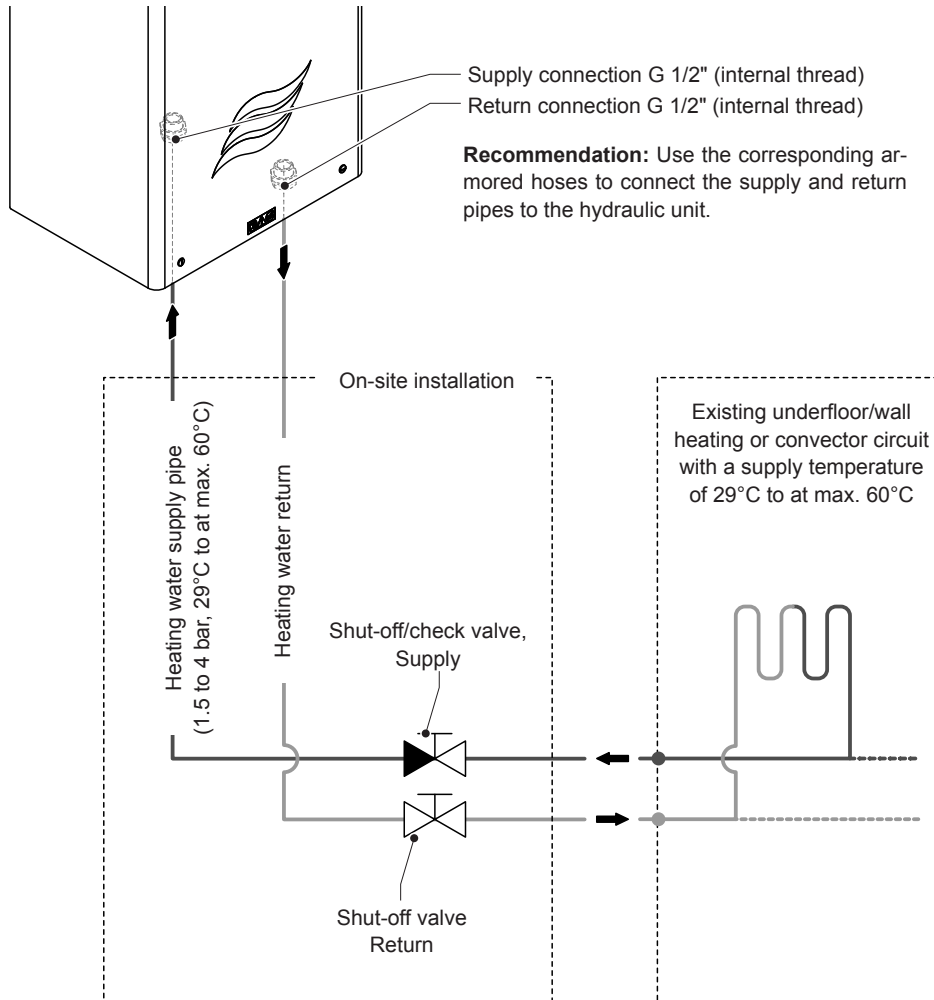


Fig. 20: Installation overview heating water connection

The following requirements must be complied with:

- The installation must comply with national and local regulations for heating water installations. At supply temperatures $>40^{\circ}\text{C}$, the supply and return pipe to the hydraulic unit must be thermally insulated.

- Permissible water temperature of the supply: 29°C to at max. 60°C

If the water temperature is higher than 60°C , a suitable mixer or scalding protection valve must be provided on site.

If the minimum temperature of the supply water cannot be maintained for long periods during operation in winter, the additional heating element in the water tank is activated for electrical reheating of the circulating water. The minimum supply water temperature must be at minimum 27°C when using the additional heating element. If you have any questions, please contact your Condair partner.

- The required hot water volume depends on the humidification demand and the temperature of the supply water and amounts to a maximum of $0.4\text{ m}^3/\text{h}$ at a flow temperature of 29°C . As the supply temperature increases, the required water volume decreases.
- Supply and return connection on the hydraulic unit: G 1/2" (internal thread)
Note: It is recommended that rigid pipes are routed up to the vicinity of the hydraulic unit and that the connection is established to the device with corresponding armored hoses.
- Permissible supply pipe water pressure: 1.5 to at max. 4 bar

The following fittings must be provided on site (see [Fig. 20](#)):

- A shut-off/check valve in the supply pipe close to the outlet from the tank or close to the branch.
- A shut-off valve in the return pipe close to the outlet of the tank or close to the branch.

The fittings must be suitable for installation in a heating system and must have been professionally installed in accordance with local regulations for heating systems.

5.9 Humidity control

The Condair MD is equipped as standard for **supply air humidity control**.

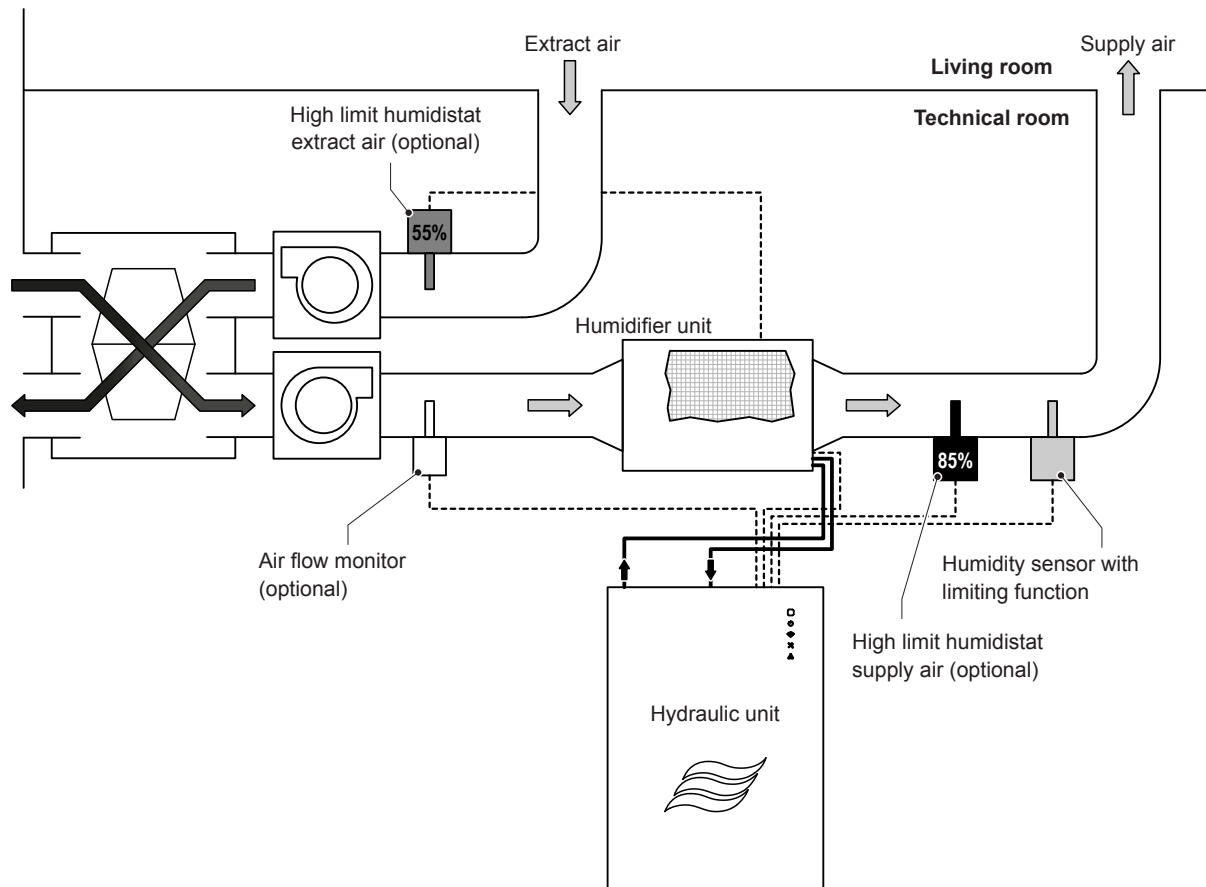


Fig. 21: Basic diagram of supply air humidity control

With the supply air humidity control, the humidity sensor (light gray) is installed in the supply air duct. It takes over the humidity control as well as the protection of the supply air duct against overhumidification. If the set target supply air humidity is exceeded for a longer period of time, a warning is triggered and the humidification is reduced.

Options for supply air humidity control

The options available for supply air humidity control serve as additional protection against possible overhumidification of the supply air duct in the event of a malfunction. Such brief overhumidification is possible if the ERV fails.

- Air flow monitor:

The optional air flow monitor is installed in downstream of the humidifier unit in the duct. It reliably detects whether the ERV has been switched off or is in a very low ECO mode (ventilation with very little air volume). If it is triggered, the Condair MD immediately stops the humidification so that no condensation can occur in the duct. At the same time, a corresponding fault is displayed via the fault LED on the hydraulic unit.

Required optional item: air flow monitor

- High limit humidistat extract air:

With the optional high limit humidistat in the extract air duct (dark gray), the humidity control of the Condair MD is extended by an additional safety element. The humidistat reliably detects when the air humidity briefly rises sharply within the premises. If such a situation occurs, the humidifier automatically throttles the supply of moisture to the duct air for the time the moisture rises. At the same time, a corresponding fault is displayed via the fault LED on the hydraulic unit.

Required optional item: High limit humidistat

- High limit humidistat supply air:

With the optional high limit humidistat in the supply air duct (black), which can also be used together with the high limit humidistat in the extract air duct, an additional safety element is added to the system. If the humidity sensor in the supply air fails after a long period of operation (e.g. due to soiling of the sensor head), the high limit humidistat can detect this and switch off the humidity supply in order to prevent uncontrolled humidification of the air. At the same time, a corresponding fault is displayed via the fault LED on the hydraulic unit.

Required optional item: High limit humidistat

Settings during initial commissioning (see operation manual for the Condair MD)

Control type:	"Supply"
High limit humidistat in the supply air duct:	85 %
High limit humidistat in the extract air duct:	55 %

5.10 Positioning and installation of the sensors

5.10.1 Positioning sensors

For the **supply air humidity control**, the sensors are to be installed as follows (see:

- The humidity sensor must be installed in the supply air duct at a minimum distance of 300 mm downstream of the humidifier unit.
- The optional high limit humidistat must be installed in the extract air duct or before of the humidity sensor (min. distance of 300 mm after the humidifier unit) in the supply air duct. A high limit humidistat can also be installed in the extract air and supply air duct.
- The optional air flow monitor must be installed in the supply air duct upstream of the humidifier unit with an inlet section of 5xDN (min. 350 mm) and a trailing section of 3xDN (min. 200 mm) (DN= nominal diameter of ventilation pipe).

Note: If ventilation pipes are installed vertically, the airflow direction must be from the bottom towards the top.

- The humidity sensor, the air flow monitor and the high limit humidistat must be installed horizontally or vertically in the ventilation duct from above.

Important: Overhead mounting is not permitted!

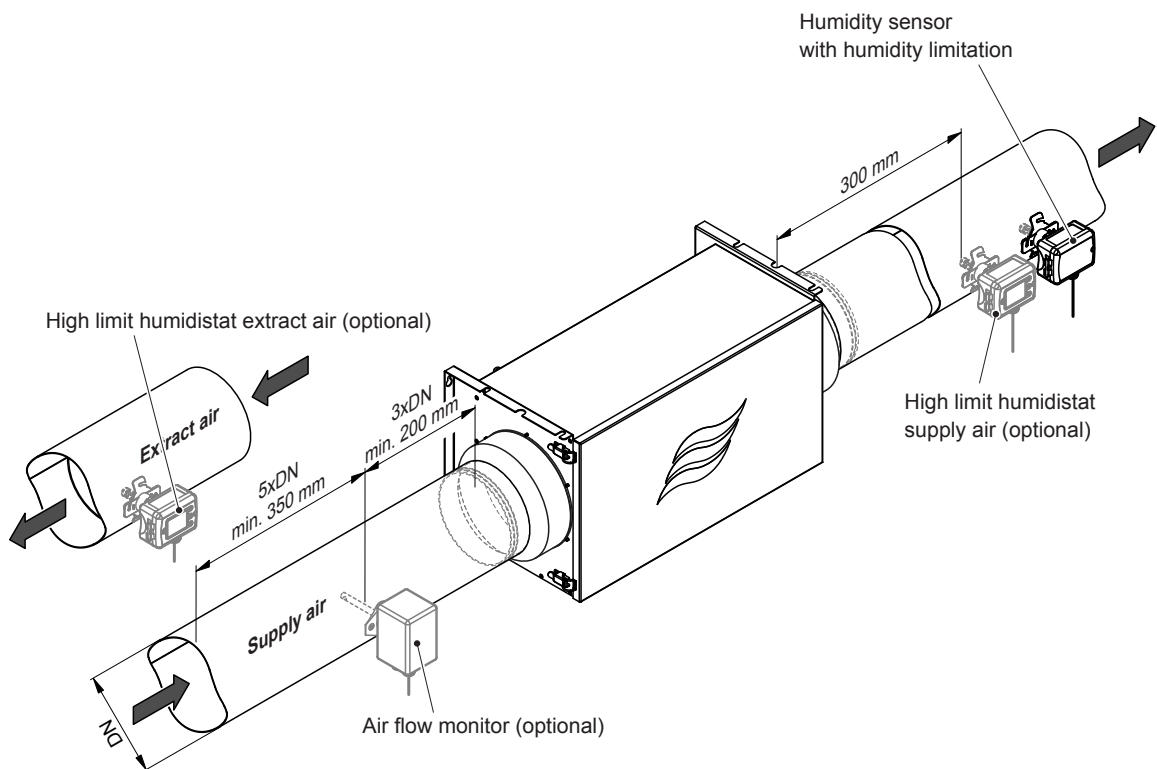


Fig. 22: Positioning the humidity and temperature sensor and monitoring devices for extract air control

5.10.1.1 Installation of the humidity sensor as well as the high limit humidistat

1. Drill the insertion hole for the sensor shaft ($\varnothing 16$ mm) into the ventilation duct (see [Fig. 22](#) for positioning).
2. Secure the sensor holder to the ventilation duct with the self-tapping screws supplied.
3. Insert the humidity sensor as well as the high limit humidistat with the rubber ring and the washer into the sensor holder and fasten with the lock nut.

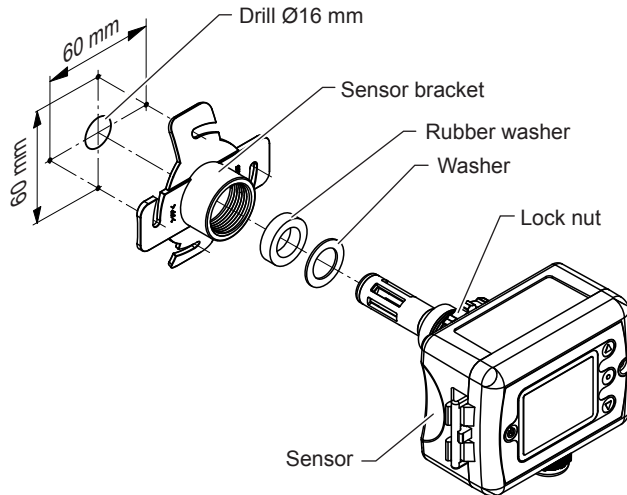


Fig. 23: Installation of the humidity and temperature sensor as well as the high limit humidistat

5.10.1.2 Mounting the airflow monitor

1. Drill the insertion hole for the sensor ($\varnothing 16$ mm) into the ventilation duct (see [Fig. 22](#) for positioning).
2. Secure the sensor bracket to the ventilation duct with the self-tapping screws supplied.
3. Insert the probe of the air flow monitor into the sensor bracket until it comes to a stop. Align flow opening exactly with the air flow. The flow opening has been aligned with the air flow when the long side of the sensor housing is at a right angle to the direction of air flow (see [Fig. 24](#)). Then secure the airflow monitor with the fixing screw.

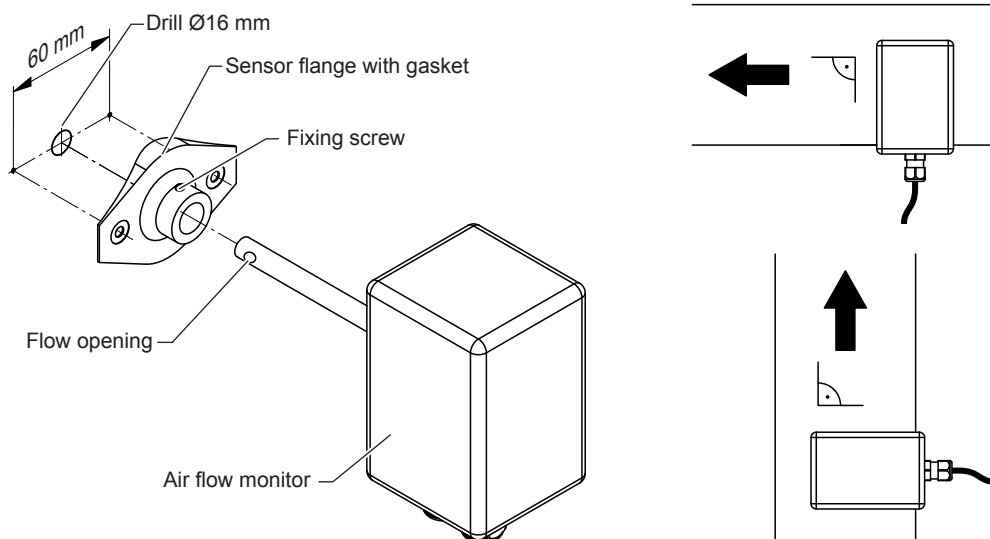


Fig. 24: Mounting the airflow monitor

5.11 Electrical installation

5.11.1 Notes on electrical installation



DANGER!
Risk of electrocution

The hydraulic unit operates using mains voltage. If the hydraulic unit is open, users may come into contact with live parts. Touching live parts may cause severe injury or death.

For this reason: Do not connect the hydraulic unit to the mains until all installation work has been completed, all installations have been checked for correct operation and the hydraulic unit has been correctly closed and locked again.



CAUTION!

Electronic components on the inside of the Condair MD hydraulic unit are very sensitive to electrostatic discharge. To protect these components, measures must be taken against damage resulting from electrostatic discharge (ESD protection) when the hydraulic unit is open for installation work.

- All electrical installation work may only be carried out by **qualified personnel** (e.g. electricians with appropriate training). It is the responsibility of the operator to check the qualification.
- The electrical installation must be carried out in accordance with the electrical diagram (see [Section 5.11.2](#)) and the instructions for electrical installation work as well as the applicable local regulations for electrical installations. All information in the electrical diagram and the supplementary instructions must be observed and complied with.
- All connecting cables must be routed into the hydraulic unit via cable bushings with strain relief (see [Section 5.11.4](#)).
- Route all electrical cables in such a way that they cannot rub against edges or cause tripping hazards.
- Maximum cable lengths and specified diameters per conductor must be complied with in accordance with local regulations.
- The supply voltage must correspond to the connection voltage on the type plate.

5.11.2 Condair MD wiring diagram

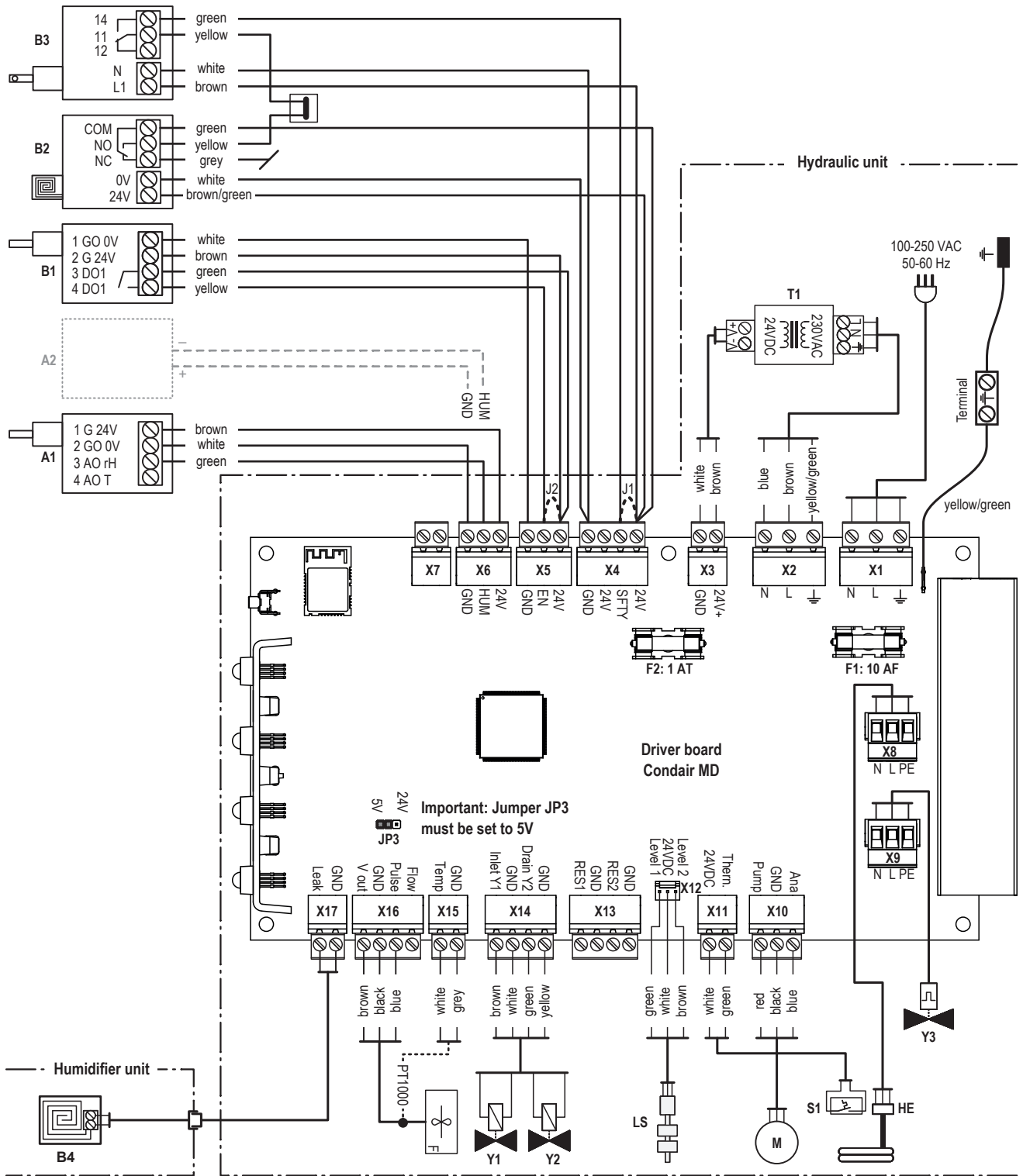


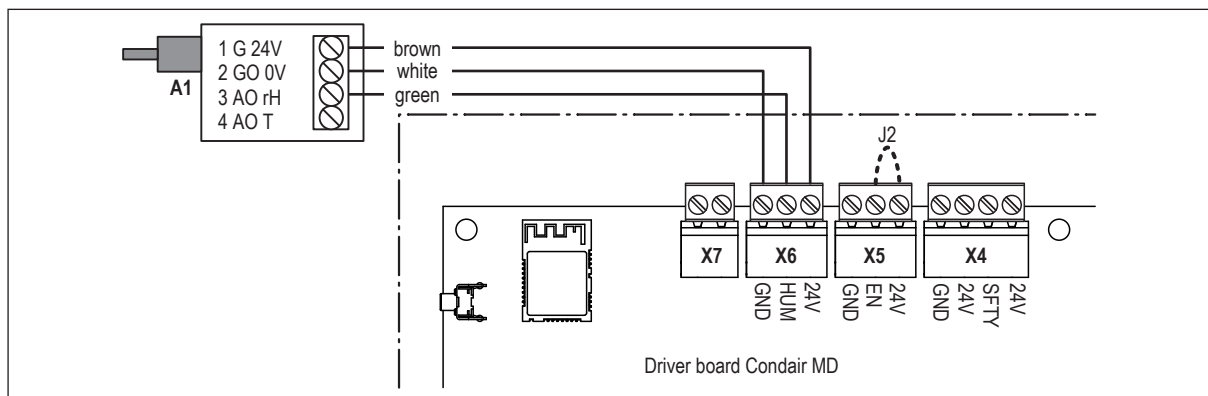
Fig. 25: Condair MD wiring diagram

Legend for the Condair MD wiring diagram

- A1 Humidity sensor, supplied, mounted in the supply air duct
- A2 External controller 0-10 V (connection instead of humidity sensor A1, by customer)
- B1 Optional high limit humidistat in the supply air (setpoint 85 %rH) or extract air duct (setpoint 55 %rH)
Important: If the high limit humidistat "B1" is not connected, a cable bridge "J2" must be connected to the terminals "24V" and "Enable" of the terminal block "X5".
- B2 Optional floor leakage sensor (external safety loop) mounted on the floor below the hydraulic unit.
Important: If neither the optional floor leakage sensor "B2" nor the optional air flow monitor "B3" are connected, a cable bridge "J1" must be connected to the terminals "24V" and "SFTY" of the terminal block "X5".
- B3 Optional air flow monitor (external safety loop).
Important: If neither the optional air flow monitor "B3" nor the optional floor leakage sensor "B2" are connected, a cable bridge "J1" must be connected to the terminals "24V" and "SFTY" of the terminal block "X5".
- B4 Leakage sensor installed in humidifier unit.
- HE Heating element
- J1 Cable bridge if neither the optional floor leak sensor "B2" nor the optional airflow monitor "B3" are connected.
- J2 Cable bridge if the optional high limit humidistat "B1" is not connected.
- JP3 Jumper must be set to 5 V. Check during installation!
- LS Level sensor
- M Circulation pump for humidifying water
- S1 Overtemperature switch heating element
- T1 Internal Transformer 230VAC/24VDC
- Y1 Inlet valve
- Y2 Drain valve
- Y3 Zone valve heating water circuit

5.11.3 Connection work for external connections

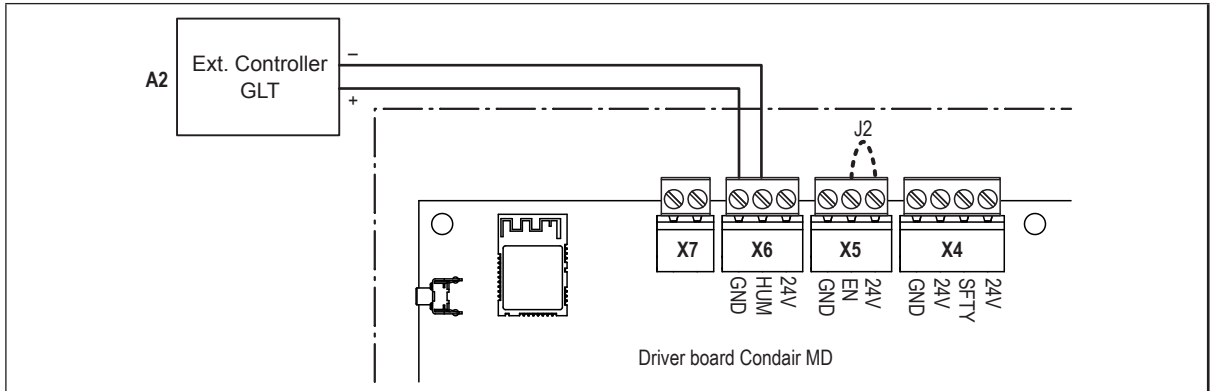
5.11.3.1 Connection of the humidity sensor with humidity control via the integrated humidity controller



The signal cable of the humidity sensor "A1" in the supply air duct is connected according to the wiring diagram to the terminals "24V", "HUM" and "GND" of the terminal block "X6" on the driver board.

Important: The cable bridge "J2" must be connected to the terminals "24V" and "EN" of the terminal block "X5" on the driver board.

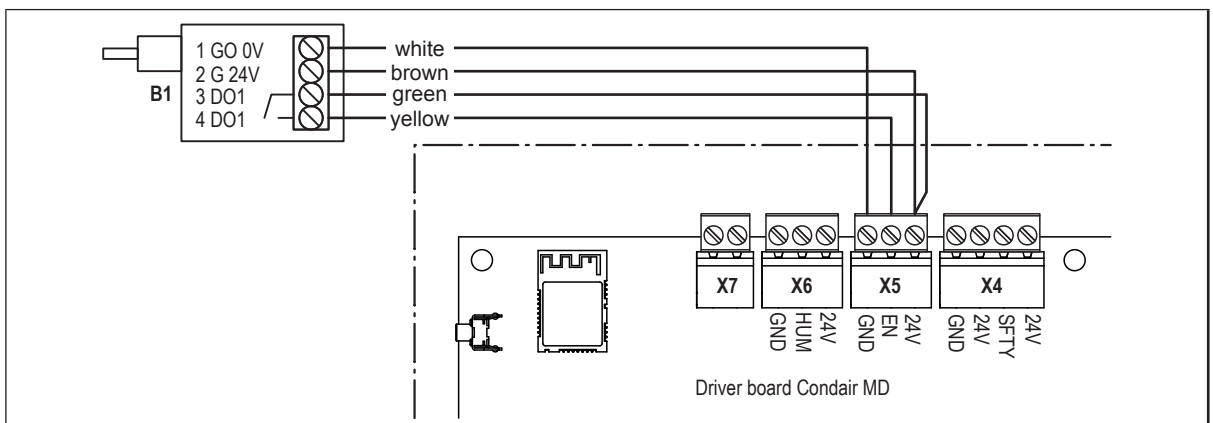
5.11.3.2 Connection of an external controller 0-10 V



If the Condair MD is to be controlled via an external controller or a BMS, the signal cable of the external controller or BMS "A2" (0-10 V) is connected according to the diagram to terminals "HUM" (+) and "GND" (-) of the terminal block "X6" on the driver board.

Important: The cable bridge "J2" must be connected to the terminals "24V" and "EN" of the terminal block "X5" on the driver board.

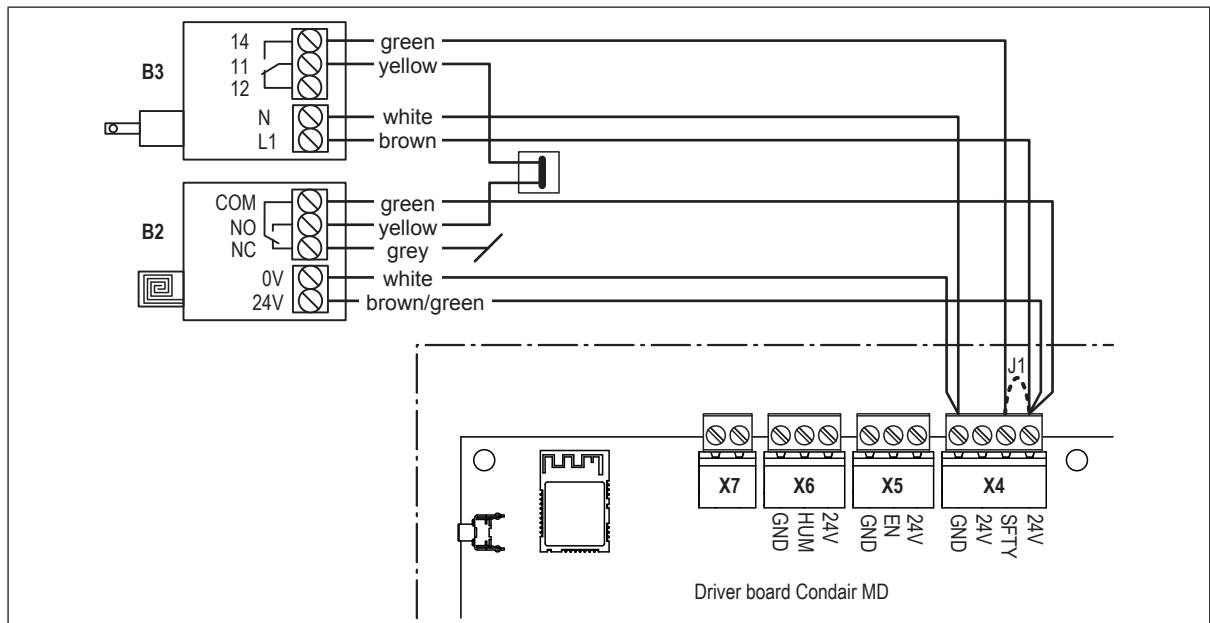
5.11.3.3 Connection of the optional high limit humidistat in the supply air or extract air duct



The connection cable of the optional high limit humidistat "B1" in the supply or extract air duct is connected according to the wiring diagram to the terminals "24V", "EN" and "GND" of the terminal block "X5" on the driver board.

Important: The cable bridge "J2" on the terminals "24V" and "EN" of the terminal block "X5" on the driver board must be removed.

5.11.3.4 Connection of the optional airflow monitor and the optional floor leak sensor

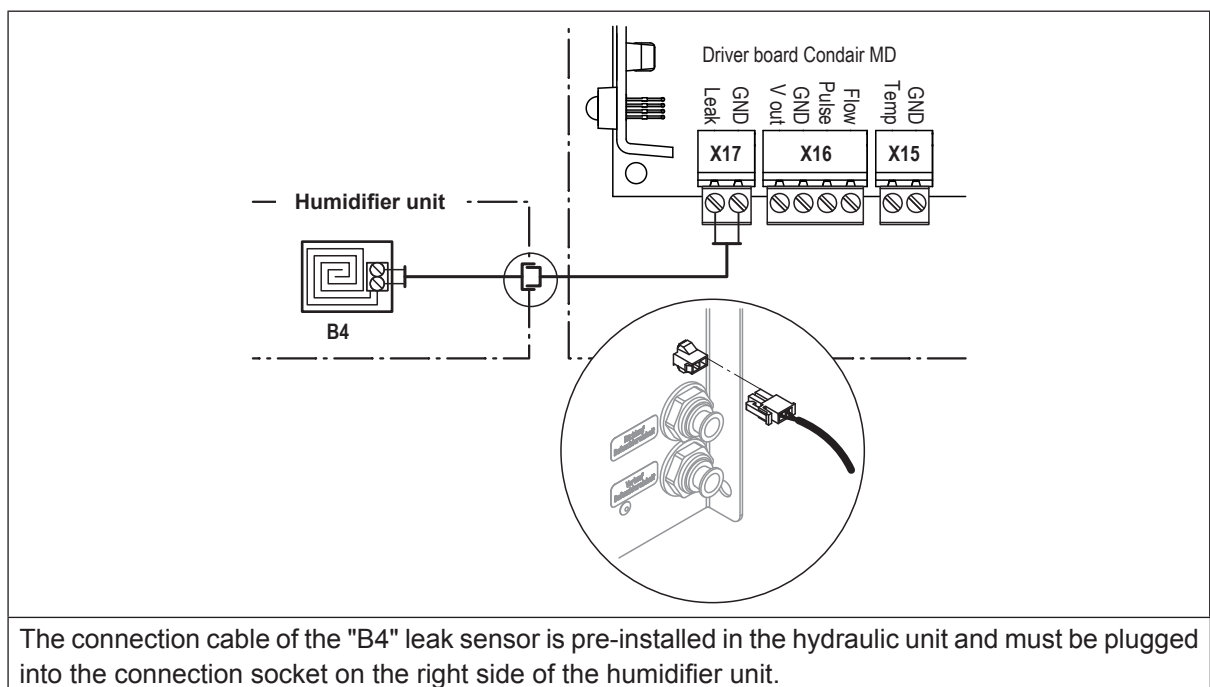


The connection cables of the optional air flow monitor "B3" and the optional floor leak sensor "B2" are connected according to the wiring diagram to the terminals "24V", "SFTY" and "GND" of the terminal block "X4" on the driver board.

Important: The cable bridge "J1" on the terminals "24V" and "SFTY" of the terminal block "X4" on the driver board must be removed.

Note: If only the air flow monitor or only the floor leak sensor is connected, the yellow wire of the air flow monitor "B3" or the floor leak sensor "B2" is connected directly to the "24V" terminal of the "X5" terminal block.

5.11.3.5 Connection of the leak sensor of the humidifier unit



The connection cable of the "B4" leak sensor is pre-installed in the hydraulic unit and must be plugged into the connection socket on the right side of the humidifier unit.

5.11.3.6 Mains connection (mains socket)

The mains socket (230V/1~/50Hz) must be provided in the immediate vicinity of the hydraulic unit in accordance with local regulations so that the pre-installed mains connection cable (L= 2 m) of the hydraulic unit can be connected to it. The mains socket must be protected with a 10 A slow-blow fuse and an RCD switch (max. 30 mA).

5.11.4 Cable entry

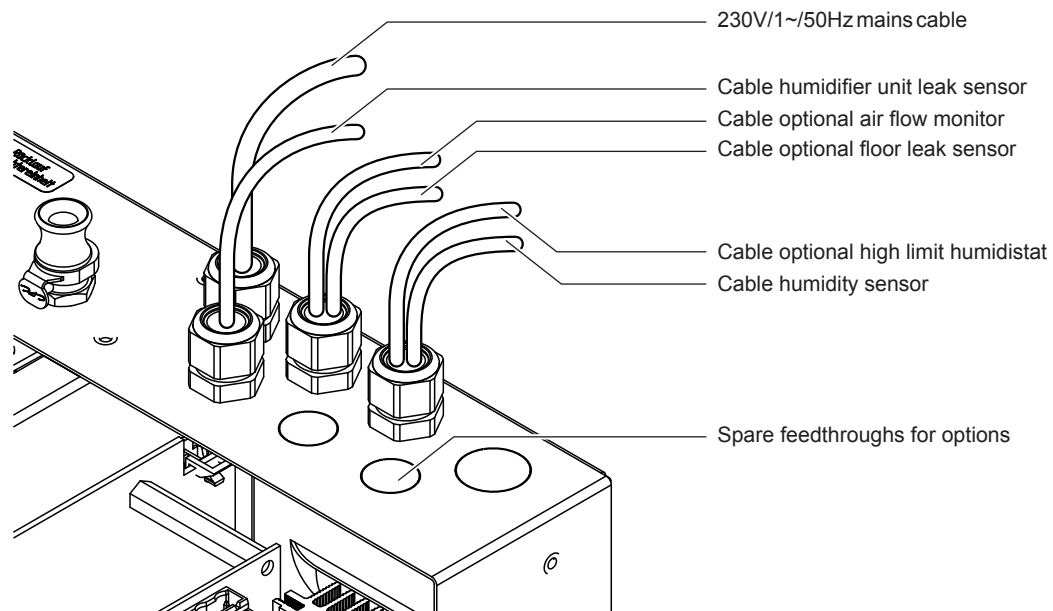


Fig. 26: Cable entry

6 Product specifications

6.1 Technical data of the hydraulic unit

	Condair MD
Dimensions/weight	
Dimensions of the hydraulic unit (HxWxD)	596 x 430 x 307 mm
Weight of the hydraulic unit	Approx. 19 kg
Hydraulics	
Flushing water quantity in standby mode	2 - 3 l per flushing process every 47 hours
Electrical system	
Connection voltage/fuse	200 to 240 VAC/50 Hz, 10 A
Power consumption, control system/heating (including solenoid valves)	700 W
Solenoid valve voltage (Y1-Y3)	24 V DC
Control signals for ext. humidity sensor	0-5VDC, 1-5VDC, 0-10VDC, 2-10VDC, 0-16VDC, 3-16VDC, 0-20VDC
Internal humidity controller	Yes
External humidity controller	Lockable
Noise emissions	
Sound level	approx. 45 dB(A)
Interfaces	
WiFi (STA- and HotSpot-Mode)	Yes
Connections towards humidifier	
Supply connection	JG ø10 mm
Return connection	JG ø10 mm
Water connections	
Fresh water supply connection	G 3/4" outer thread
Permissible water connection pressure	Flow pressure 150 to 500 kPa (1.5 to 5 bar)
Permissible water temperature	min. 8°C/max. 30°C
Water quality requirements	Drinking water without additives Permissible water hardness: 1 to 30 °dH Permissible pH value: 6.5 to 9.0
Water drain connection	Adapter to ø40 mm
Protection type	IP20
Conformity	CE

6.2 Technical data of humidifier unit

Dimensions/weight	
Installation length in the ventilation unit/air duct	
– with transition pieces DN125	727 mm
– with transition pieces DN160	693 mm
– with transition pieces DN180	673 mm
– without transition pieces (DN200)	547 mm
Humidifier unit length	610 mm
Humidifier unit width	288 mm
Humidifier unit height	320 mm
Humidifier unit weight empty/in operation	12 kg / 18 kg
Hydraulics	
Humidification output	2 kg/h
Air	
Pressure drop	10 Pa @ 300 m ³ /h
Druckabfall mit optionalem Filter ISO ePM1 60%	37 Pa @ 300 m ³ /h
Air filter quality upstream of humidifier unit	min. ISO Coarse 80%, recommended ISO ePM1 60%
Min. recommended air temperature	14°C (upstream of humidifier unit)
Max. recommended air temperature	40°C (upstream of humidifier unit)
Water	
Supply connection	JG ø10 mm
Return connection	JG ø10 mm
Protection type	IP22
Test certificates	CE

7 Appendix

7.1 Dimensional drawing of humidifier unit

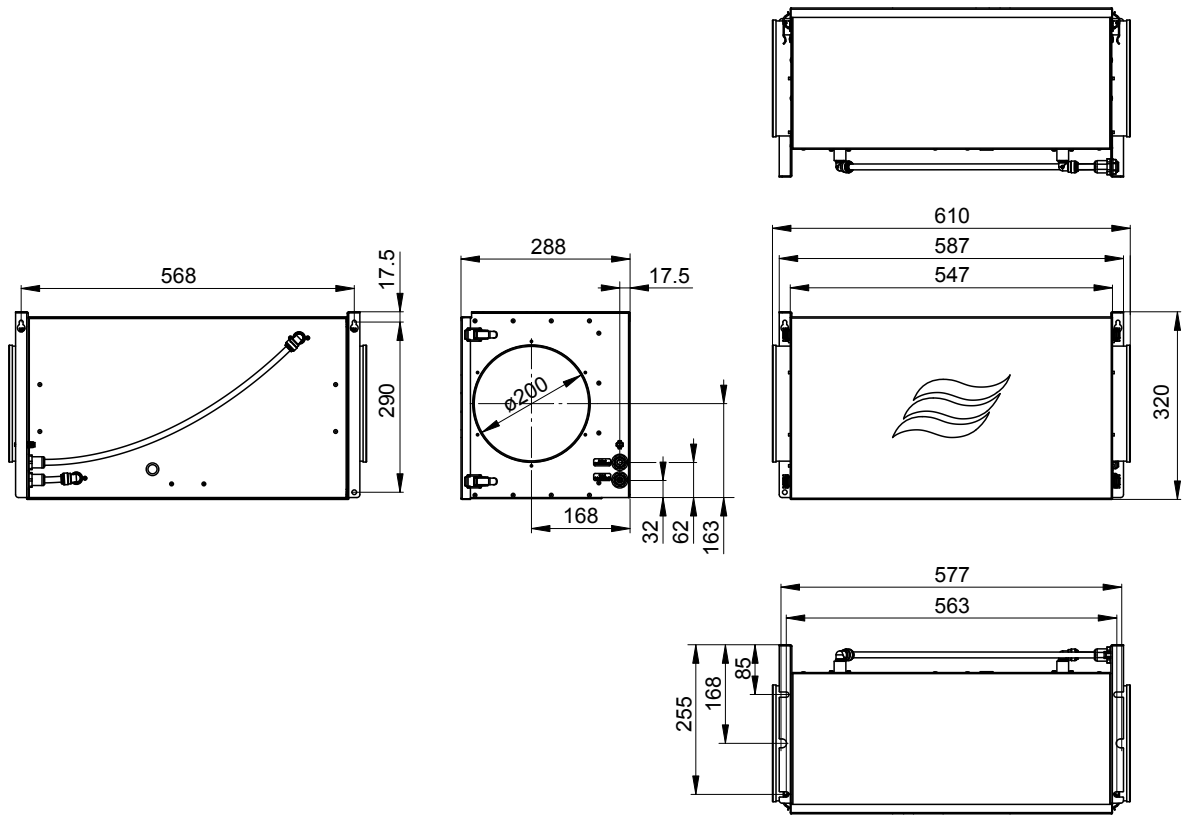


Fig. 27: Dimensional drawing of humidifier unit (dimensions in mm)

7.2 Dimensional drawings of adapters

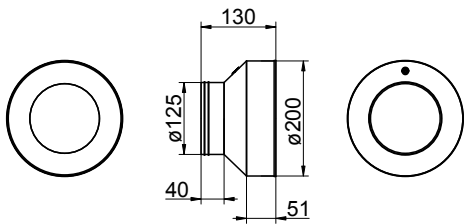


Abb. 28: Dimensional drawing of DN125 adapter (dimensions in mm)

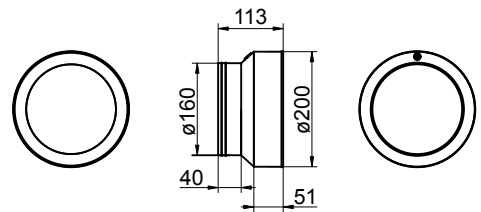


Abb. 29: Dimensional drawing of DN160 adapter (dimensions in mm)

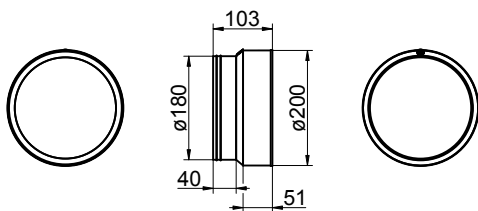


Abb. 30: Dimensional drawing of DN180 adapter (dimensions in mm)

7.3 Dimensional drawing of hydraulic unit

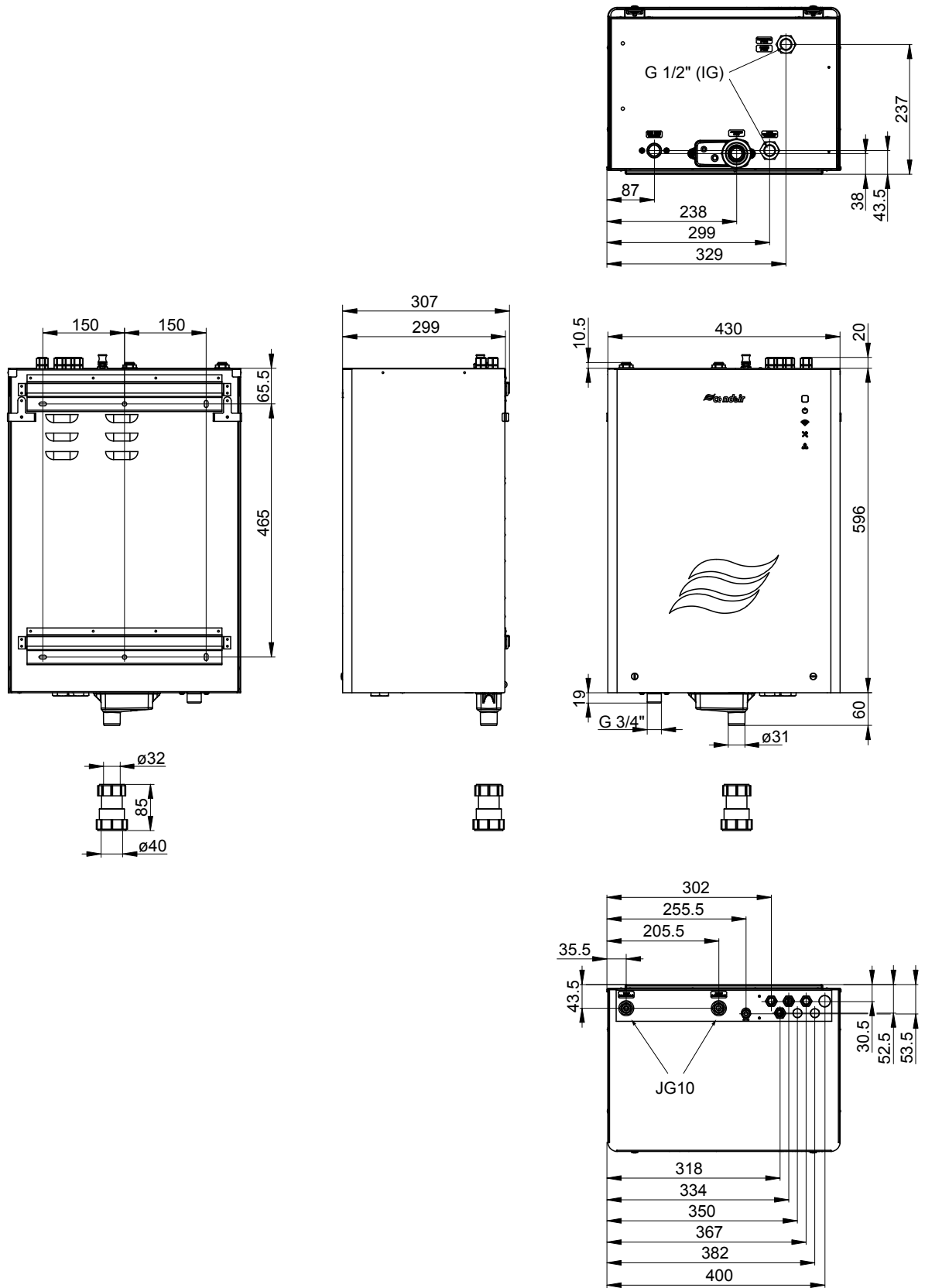
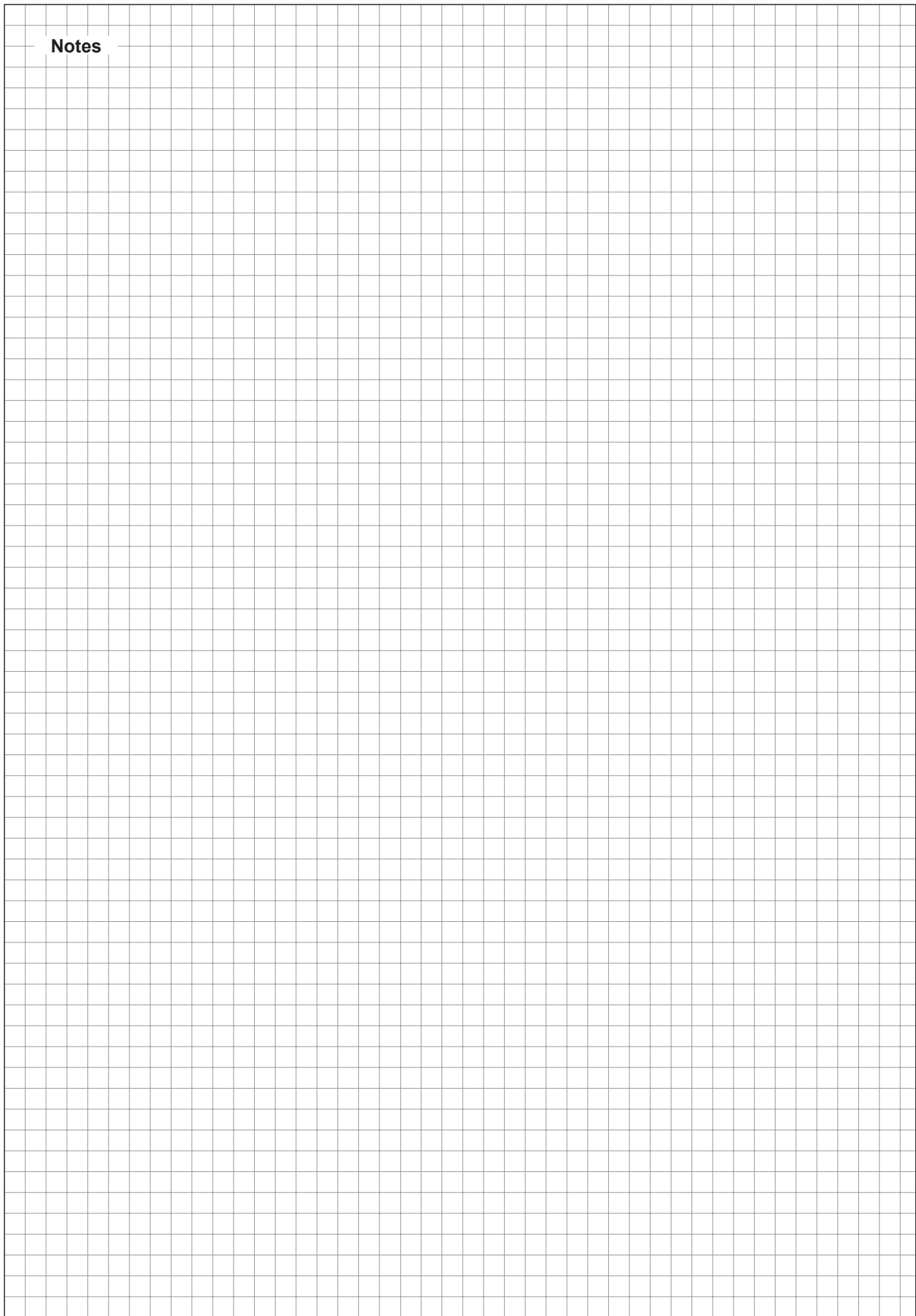
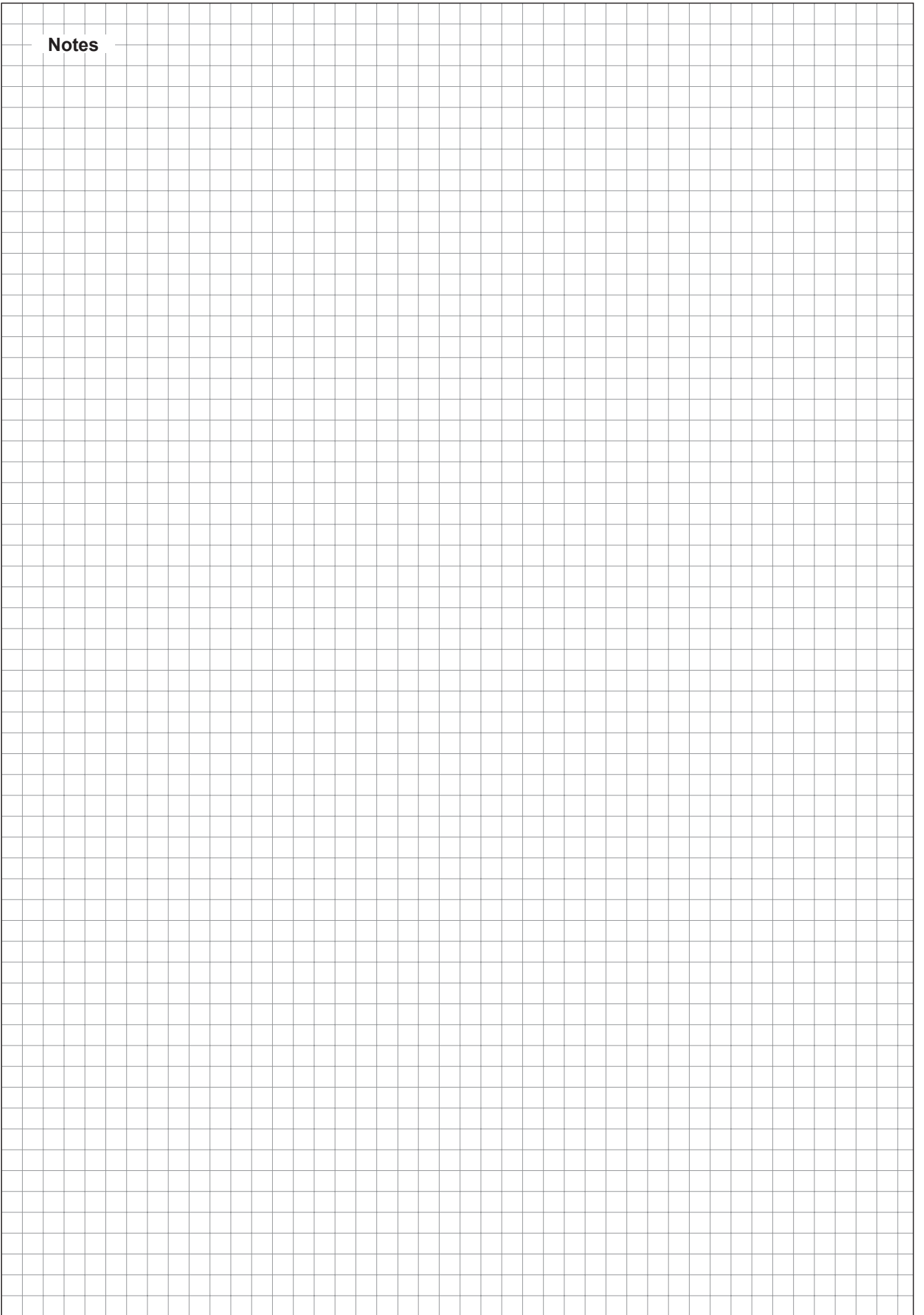


Fig. 31: Dimensional drawing of hydraulic unit (dimensions in mm)

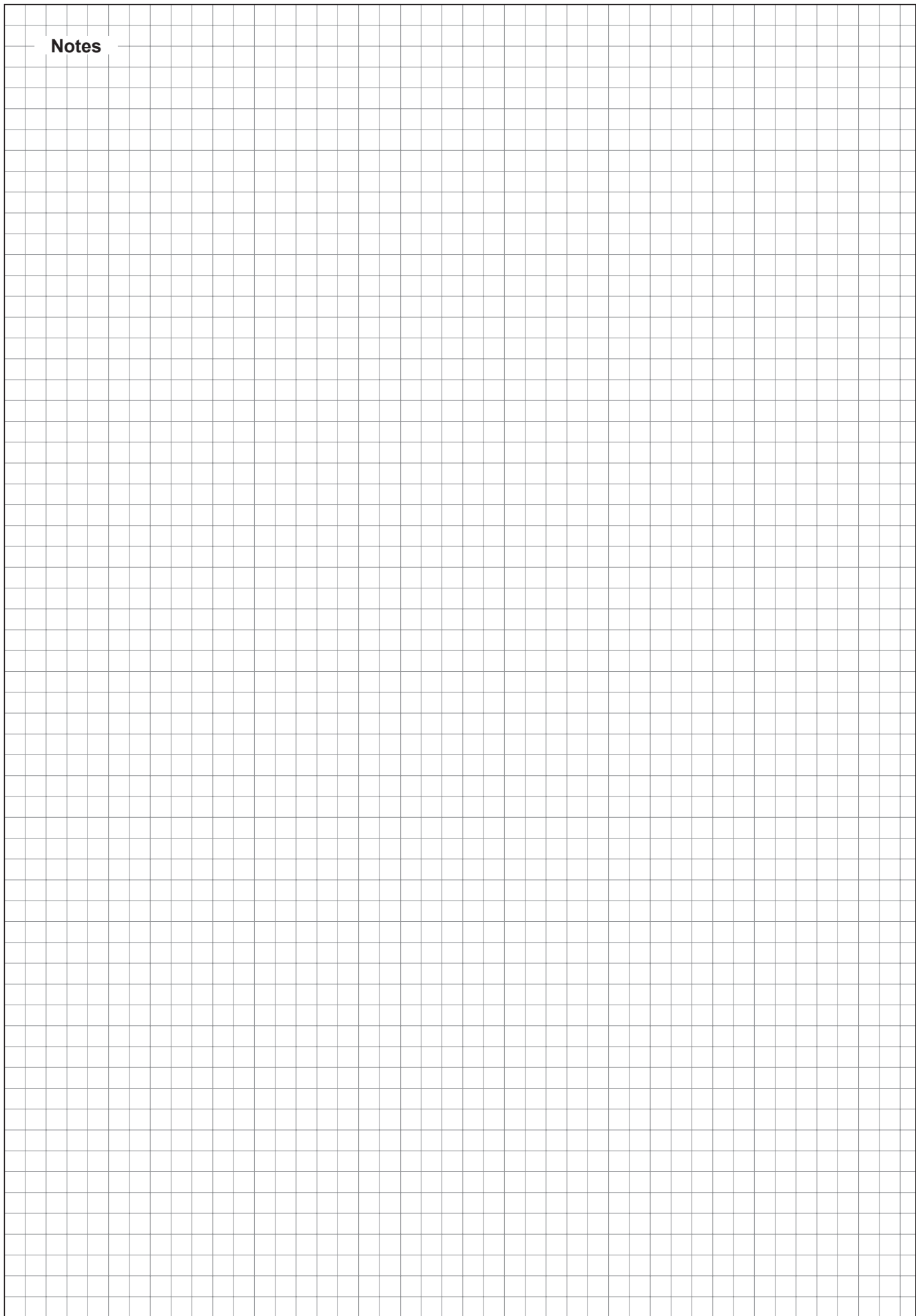
Notes



Notes



Notes



CONSULTING, SALES AND SERVICE:



CH94/0002.00

Condair Group AG
8808 Pfäffikon SZ, Switzerland
www.condairgroup.com

