

# INSTALLATION AND OPERATION MANUAL

Direct Room Humidification System  
Condair Vita

# Thank you for choosing Condair

Installation date (DD/MM/YYYY):

Commissioning date (DD/MM/YYYY):

Installation site:

Model:

Serial number:

## **Proprietary rights**

This document and the information disclosed herein are proprietary data of Condair Group AG. This instruction manual (including extracts thereof) may not be reproduced or passed on, nor may the contents thereof be used by or passed on to any third party without the written permission of Condair Group AG. Any infringements are punishable and entail a liability for damages.

## **Liability**

Condair Group AG is not liable for any damages incurred as a result of poorly executed installation, improper operation or the use of components or equipment not approved by Condair Group AG.

## **Copyright notice**

© Condair Group AG, all rights reserved

Subject to technical alterations

# Contents

<b>1</b>	<b>Introduction</b>	<b>6</b>
1.1	First things first!	6
1.2	Notes on the installation and operation manual	6
<b>2</b>	<b>For your safety</b>	<b>9</b>
2.1	Intended use	9
2.2	General safety notices	9
<b>3</b>	<b>Product overview</b>	<b>11</b>
3.1	Overview Condair nebulizers	11
3.2	General description of the Condair Vita nebulizers	12
3.3	Condair Vita Sky S nebulizers	13
3.3.1	Structure of the Condair Vita Sky S nebulizers	13
3.3.2	Versions of the Condair Vita Sky S nebulizer	14
3.3.3	Accessories for Condair Vita Sky M1 and Condair Vita Sky M2 nebulizers	14
3.4	Condair Vita Sky M1 and Condair Vita Sky M2 nebulizers	15
3.4.1	Structure of the Condair Vita Sky M1 and Condair Vita Sky M2 nebulizers	15
3.4.2	Versions of the Condair Vita Sky M1 and Condair Vita Sky M2 nebulizers	16
3.4.3	Accessories for Condair Vita Sky M1 and Condair Vita Sky M2 nebulizers	16
3.5	Condair Vita Sky T1 and Condair Vita Sky T2 nebulizers	17
3.5.1	Structure of the Condair Vita Sky T1 and Condair Vita Sky T2 nebulizers	17
3.5.2	Versions of the Condair Vita Sky T1 and Condair Vita Sky T2 nebulizers	18
3.6	Condair Vita Stream nebulizer	19
3.6.1	Structure of the Condair Vita Stream nebulizer	19
3.6.2	Versions of the Condair Vita Stream nebulizer	20
3.6.3	Accessories for Condair Vita Stream nebulizers	21
3.7	Condair Vita Line nebulizer	22
3.7.1	Structure of the Condair Vita Line nebulizer	22
3.7.2	Versions of the Condair Vita Line nebulizer	23
3.7.3	Components for Condair Vita Line nebulizers	23
3.8	Condair Vita Space nebulizer	25
3.8.1	Structure of the Condair Vita Space	25
3.8.2	Versions of the Condair Space nebulizer	26
3.8.3	Accessories for Condair Vita Space nebulizers	27
3.9	Zone valves	28
3.10	Control devices	29
3.10.1	System Master	29
3.10.2	External control unit	29
3.10.3	HumPower	30
3.10.4	HumPower 24V	31
3.10.5	CAN bus extender	31
3.10.6	Industrial sensor gateway with industrial humidity sensor	32
3.10.7	HumSpot	33
3.10.8	Safety humidistat	33
3.10.9	Junction Box	33

<b>4</b>	<b>Installation overviews</b>	<b>34</b>
4.1	Installation example "Ring line"	34
4.2	Installation examples "String line"	35
4.3	System Restrictions	38
4.3.1	CAN bus system limitations	38
4.3.2	Max. number of nebulizers and max. number of HumPower 24 V per HumPower	38
4.3.3	Max. number of nebulizers per HumPower 24 V:	38
<b>5</b>	<b>Mounting</b>	<b>39</b>
5.1	Mounting the nebulizers	39
5.1.1	General information on positioning	39
5.1.2	Positioning and mounting the Condair Vita Sky S/M1/M2 nebulizers	40
5.1.2.1	Positioning and mounting the Condair Vita Sky S/M1/M2 nebulizers	40
5.1.2.2	Wall mounting of the Condair Vita Sky S/M1/M2 nebulizers	41
5.1.2.3	Ceiling mounting of the Condair Vita Sky S/M1/M2 nebulizers with standard ceiling bracket	42
5.1.2.4	Ceiling mounting of the Condair Vita Sky S/M1/M2 nebulizers with premium ceiling bracket	43
5.1.3	Positioning and mounting the Condair Vita Sky T1/T2 nebulizers	45
5.1.3.1	Positioning the Condair Vita Sky T1/T2 nebulizers	45
5.1.3.2	Wall mounting of the Condair Vita Sky T1/T2 nebulizers	46
5.1.4	Positioning and mounting the Condair Vita Stream nebulizer	47
5.1.4.1	Additional information on positioning the Condair Vita Stream nebulizer	47
5.1.4.2	Positioning the Condair Vita Stream nebulizer	47
5.1.4.3	Mounting the Condair Vita Stream nebulizer	48
5.1.5	Positioning and mounting the Condair Vita Line nebulizer	49
5.1.5.1	Additional positioning instructions for the Condair Vita Line nebulizer	49
5.1.5.2	Positioning the Condair Vita Line nebulizers	50
5.1.5.3	Assembly of the Condair Vita Line nebulizer	52
5.1.5.4	Connecting the high-pressure hose	54
5.1.5.5	Inserting the nozzles	55
5.1.5.6	Wall mounting of the Condair Vita Line nebulizer	56
5.1.6	Positioning and mounting the Condair Vita Space nebulizer	57
5.1.6.1	General notes on positioning	57
5.1.6.2	Positioning the Condair Vita Line nebulizers	58
5.1.6.3	Inserting the nozzle	60
5.1.6.4	Mounting the Condair Vita Space nebulizers	61
5.1.6.5	High pressure and power supply connection	63
5.2	Mounting the zones valves	65
5.3	Hydraulic connection of the nebulizers	68
5.3.1	Dimensioning examples of high-pressure ring line with high pressure hoses	68
5.3.2	Dimensioning examples of high-pressure ring line with stainless steel pipe	69
5.3.3	Dimensioning examples of high-pressure string line with high-pressure hose	69
5.3.4	General information	71
5.3.5	Cutting the high-pressure hoses	71
5.3.6	Compressing the high-pressure hoses	72
5.4	Positioning and mounting of the control components	73
5.4.1	Positioning and mounting the HumPower	73
5.4.2	Positioning and mounting the HumPower 24V	74
5.4.3	Positioning and mounting the CAN-Bus Extender	75
5.4.4	Positioning and mounting the junction boxes	76
5.4.5	Positioning and mounting the industrial sensor gateways	77
5.4.6	Positioning and mounting the industrial humidity sensor	78
5.4.7	Positioning and mounting the HumSpot	78
5.4.8	Positioning and mounting the safety humidistat	78

5.5	Electrical connection of the nebulizers	79
5.5.1	General connection instructions	79
5.5.2	HumPower connections	80
5.5.3	HumPower 24V connections	82
5.5.4	24 VDC power supply to Condair Vita Sky S/M1/M2 nebulizers	84
5.5.5	Connection of the zone valve for Condair Vita Sky S/M1/M2 string line type nebulizers	85
5.5.6	24 VDC power supply for zone valve and 115/230 VAC power supply for Condair Vita Stream nebulizer	87
5.6	CAN bus connections	89
5.6.1	Industrial sensor gateway connections and industrial sensor	91
<b>6</b>	<b>Operation</b>	<b>94</b>
6.1	Initial commissioning	94
6.2	Inspections during operation	95
6.3	Shutting-down	95
<b>7</b>	<b>Maintenance</b>	<b>96</b>
<b>8</b>	<b>Troubleshooting / replacement of defective components</b>	<b>97</b>
8.1	Error list	97
8.2	Replacement of defective nozzles	99
8.3	Replacing the defective nebulizers	100

# 1 Introduction

---

## 1.1 First things first!

Thank you for choosing the Condair direct room humidification system based on the Condair Vita high pressure water treatment systems and the Condair Vita nebulizers.

The Condair direct room humidification systems have been built using state-of-the-art technology and in accordance with the latest technical regulations. However, improper use of the systems may put users and/or third parties at risk and may also cause damage to material assets.

To ensure safe, proper and cost-efficient operation, please observe and comply with all information and safety instructions in this installation and operation manual.

If you have any questions after reading this manual, please contact your local Condair representative. He will be glad to assist you.

## 1.2 Notes on the installation and operation manual

### **Delimitations**

The subject of this installation and operation manual is the Condair direct room humidification system based on the Condair Vita high pressure water treatment systems, the Condair Vita nebulizers and the associated control devices. Other parts of the system are only described insofar as is necessary for the proper installation and operation of the humidification system.

The explanations in this installation and operation manual are limited to the installation, commissioning, operation, maintenance and troubleshooting of the Condair nebulizers.

This installation and operation manual are supplemented by various separate documentation (spare parts list, diagrams, etc.). Where necessary, you will find corresponding cross-references to these publications in the installation and operation manual.

## Agreements



### CAUTION!

The signal word "CAUTION" together with the hazard symbol in a circle indicates information provided in this documentation which, if ignored, could lead to **damage and/or the failure of the device or other equipment**.



### WARNING!

The signal word "WARNING", together with the general hazard symbol, indicates safety and hazard information given in this documentation which, if ignored, **could lead to injury to people**. Other specific hazard symbols may also be used in place of the general symbol.



### DANGER!

The signal word "DANGER", together with the general hazard symbol, indicates safety and hazard information given in this documentation which, if ignored, could lead to **severe injuries to persons or death**. Other specific hazard symbols may also be used in place of the general symbol.

## Storage

Please keep this installation and operation manual in a safe place where they can be accessed at all times. If the documentation is lost, please contact your Condair representative.

## Language versions

This installation and operation manual is available in various languages. For more information, please contact your Condair representative.

## Definitions

- **Raw water:**  
Raw water/mains water refers to drinking or tap water.
- **Soft water:**  
Soft water refers to water produced by a water softener. The water softening process involves replacing the water hardeners calcium and magnesium with sodium.
- **Pure water (Reverse osmosis water):**  
Pure water or reverse osmosis water (RO water) refers to water demineralized by the RO stage of the Condair Vita high pressure water treatment system. Pure water is indispensable as a precursor for the smooth operation of the synthesis stage (DI-CO<sub>2</sub> stage).
- **Ultrapure water (fully demineralized water):**  
Ultrapure, or purified, water contains no minerals. The purified water is produced with a synthesis cartridge in the DI-CO<sub>2</sub> stage of the Condair Vita high pressure water treatment system. The synthesis cartridge removes the remaining minerals from pure water (RO water).
- **Product:**  
The product is also produced in the DI-CO<sub>2</sub> stage of the Condair Vita high pressure water treatment system. The ultrapure water (demineralized water) is conditioned with an additive and is then suitable for humidifying rooms, etc.
- **Additive:**  
The additive is CO<sub>2</sub> (carbon dioxide) gas, which is added to the deionized water in the DI-CO<sub>2</sub> stage of the Condair Vita high pressure water treatment system to enable humidification with the deionized water.

## 2 For your safety

---

### 2.1 Intended use

The Condair direct room humidification system is intended **only for controlled air humidification within the specified operating parameters in areas that are not potentially explosive. Any other use is deemed improper and can render the system hazardous.**

Intended use also includes compliance with all information in these instructions (particularly the safety instructions) and strict compliance with the operating conditions.

### 2.2 General safety notices

- The humidification system may only be installed and operated by persons familiar with the product and adequately qualified for the respective work. It is the customer's responsibility to ensure that the installation and operation manual are supplemented by in-house instructions regarding supervision and reporting requirements, work organization, personnel qualification, etc.
- **Before commencing any work on components** of the humidification system, it must be **properly shut down** and protected against unintentional start-up (disconnect from the power supply, shut off water supply and depressurize systems).
- Observe **all local safety regulations**:
  - for handling mains-powered **electrical and electronic devices**.
  - for **use with water and low pressure air systems**.
- Poorly maintained humidification systems can endanger health. The maintenance intervals must therefore be strictly observed and the maintenance work carried out correctly.
- If it can be assumed that **safe operation is no longer possible**, then the humidification system **must be shut down immediately, safeguarded against accidental switching on** and Condair must be informed. This may occur under the following circumstances:
  - if system components are damaged.
  - if the system is no longer working correctly.
  - if connections or pipes are leaking.
- The nebulizers are IP21 protected. Ensure that the equipment at the installation site is protected against dripping water and splash water.
- To avoid water damage, do not store water-sensitive materials directly under the system components.
- **CAUTION Risk of corrosion!** To avoid damage, there should be no corrosion-sensitive components in the area of the aerosol mist. The specified clearances below and in front of the nebulizers must be strictly observed (see [Section 5.1.2.1](#), [Section 5.1.3.1](#) and [Section 5.1.4.2](#)).

- The nebulizers must only be operated with treated water (pure or ultrapure water).



**DANGER!**  
**Health risk!**

**Due to health risks, the silicate content in the supply water to the nebulizers – in any form – must not exceed 12 mg/l.**

If the silicate content of the supply water is higher a silicate filter must mandatory be installed in the water supply line before the water treatment system by the customer.

For further product-specific restrictions on water treatment system with regard to the silicate content, please note the relevant water supply requirements for the respective water treatment system.

- Depending on the mineral content in pure water (generated by water softener and reverse osmosis), a higher or lower level of mineral precipitation may form in the area of the aerosol mist. Sensitive materials and devices must be protected accordingly or removed from the area.
- Apart from the work described in this manual, no further interventions may be carried out on the humidification system.
- Only use original Condair accessories and spare parts.
- No modifications may be made to the humidification system without the written consent of Condair.
- Any changes to the system are subject to approval from Condair's customer service or persons authorized by Condair prior to it being started up for the first time.
- The highest level of hygiene is ensured right from the packaging and shipment of the goods. The goods may only be stored in dry, clean rooms where there is no risk of frost. Only remove the goods from the packaging immediately before installation in order to protect them against soiling of any kind. Please remove system parts that are only required for commissioning immediately before they are removed from the packaging.

**Recommendation for fire extinguishing system:**

Fire extinguishers suitable for use of electrical facilities up to 1000 V are permitted. Extinguishing agents may include BC extinguishing powder or carbon dioxide (CO<sub>2</sub>).

# 3 Product overview

## 3.1 Overview Condair nebulizers

The Condair nebulizers are available in different versions for different humidification performances and applications.

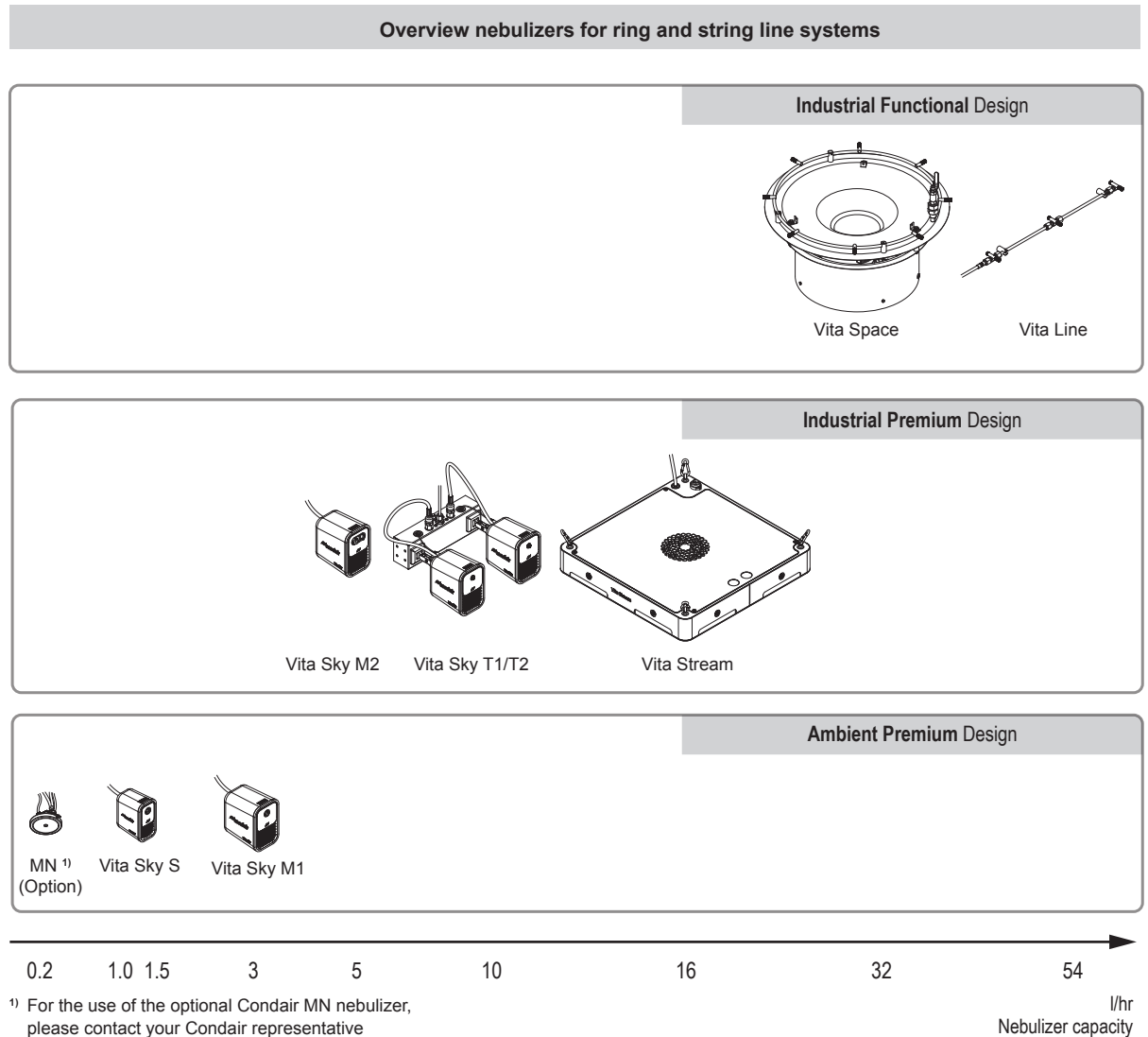

Fig. 1: Overview Condair nebulizers

## 3.2 General description of the Condair Vita nebulizers

The Condair Vita nebulizers have a connection for high-pressure pure water and a connection for the power supply (Exception: The Condair Vita Line nebulizers do not have a power supply). The Condair Vita nebulizers are supplied with high-pressure pure water and controlled by the Condair Vita high pressure water treatment system. The Condair Vita Sky and Stream nebulizers are powered by the Condair Vita HumPower and/or the Condair Vita HumPower 24V. The Condair Vita Space nebulizers are directly powered via a 115/230V mains supply.

The Condair Vita nebulizers are individually arranged in the respective humidification zone. Different types of Condair Vita nebulizers can be used individually. The room humidity in the humidification zone is measured via a HumSpot, a humidistat, or an industrial humidity sensor. As soon as the humidity setpoint is undershot in a humidification zone, the humidification zone requests water. When the humidification zone receives information from the System Master of the Condair Vita high-pressure water treatment system that the operating pressure of 70 bar has been reached, it activates the nebulizers (ring line systems) or the zone valves (spur line systems) with their respective supply voltage. As soon as voltage is applied to the nebulizers or zone valves, the integrated solenoid valves open, and humidification is activated.

### 3.3 Condair Vita Sky S nebulizers

#### 3.3.1 Structure of the Condair Vita Sky S nebulizers

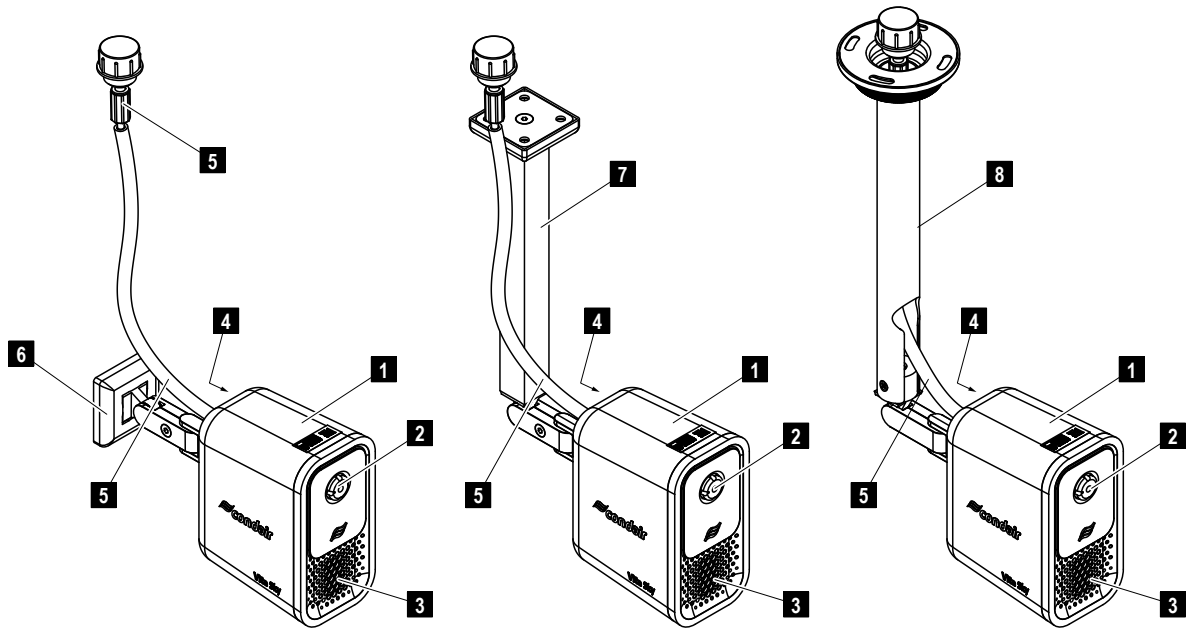
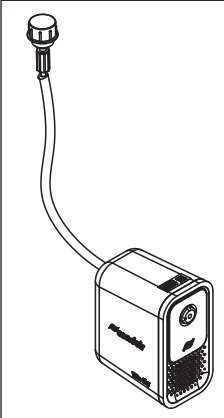
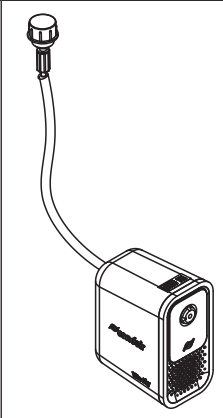

Fig. 2: Structure of the Condair Vita Sky S nebulizers

#### Key

- |   |   |   |   |
|---|---|---|---|
| 1 | Condair Vita Sky S nebulizer  | 6 | Wall bracket for mounting and alignment of the nebulizer.             |
| 2 | High-pressure nozzle  | 7 | Ceiling bracket for mounting and alignment of the nebulizer           |
| 3 | Fan outlet opening  | 8 | Ceiling bracket "Premium" for mounting and alignment of the nebulizer |
| 4 | Power supply connector  |   |   |
| 5 | High pressure hose with quick coupling for hydraulic connection to ring line. |   |   |

### 3.3.2 Versions of the Condair Vita Sky S nebulizer

Condair Vita Sky S		
		
Humidification capacity	0.9 l/hr	1.5 l/hr
Nozzle type	Diva S	Diva M
Number of nozzles	1	
High pressure line type	Ring line	
High pressure connector	M16	
Voltage	24 VDC	
Power consumption	5 W	
Dimensions (H x W x D)	119 mm x 62 mm x 98 mm	
Weight	0.5 kg	
Operating pressure	approx. 70 bar	
Ambient temperature	7...35 °C	
Ambient humidity	max. 95 %	
Protection class	IP20	

### 3.3.3 Accessories for Condair Vita Sky M1 and Condair Vita Sky M2 nebulizers

Some of the following parts and spare parts may only be available in selected markets. Contact your local Condair representative for more information on pricing and lead times.

Item
Wall bracket for wall mounting of the Condair Vita Sky M1 and Condair Vita Sky S nebulizers
Ceiling bracket for ceiling mounting of the Condair Vita Sky S nebulizers
Ceiling bracket "Premium" for ceiling mounting of the Condair Vita Sky S nebulizers

### 3.4 Condair Vita Sky M1 and Condair Vita Sky M2 nebulizers

#### 3.4.1 Structure of the Condair Vita Sky M1 and Condair Vita Sky M2 nebulizers

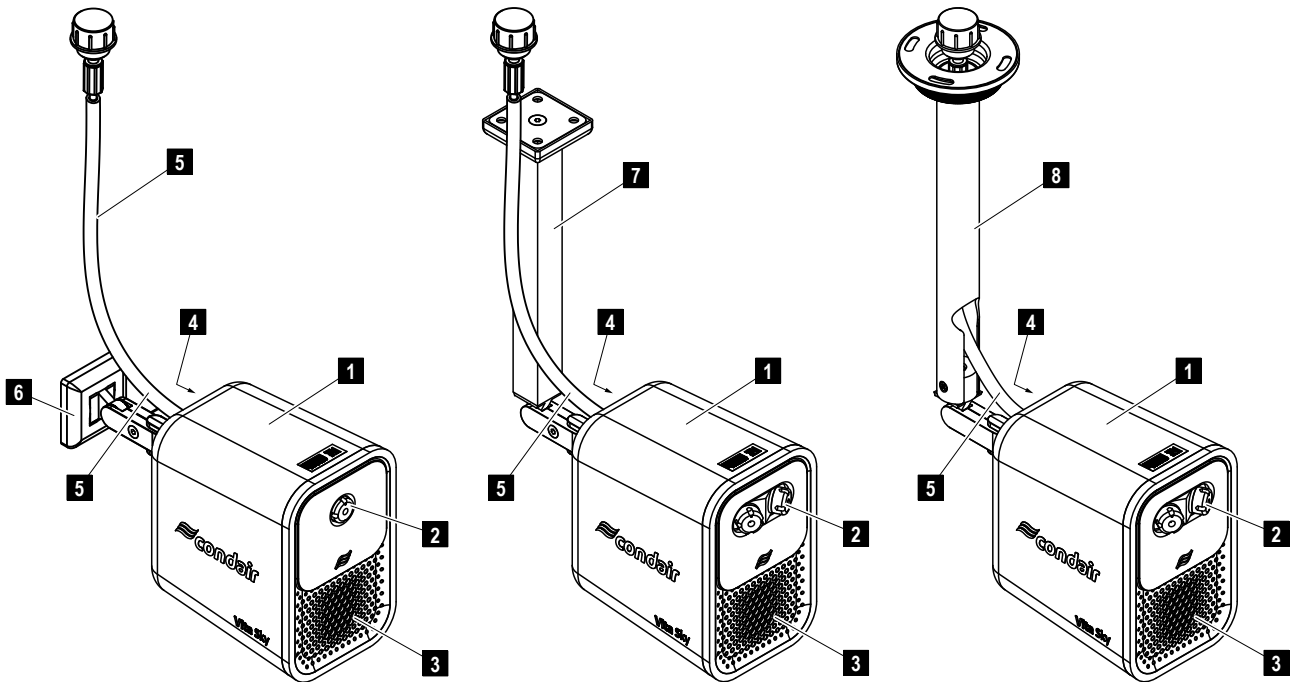
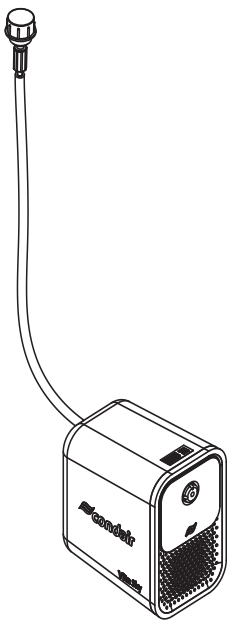
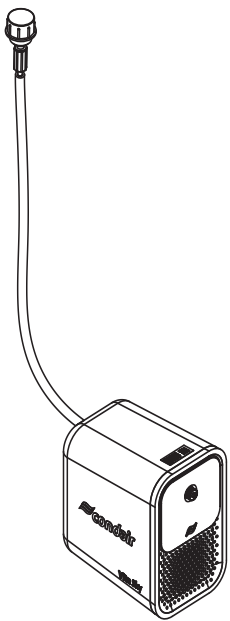
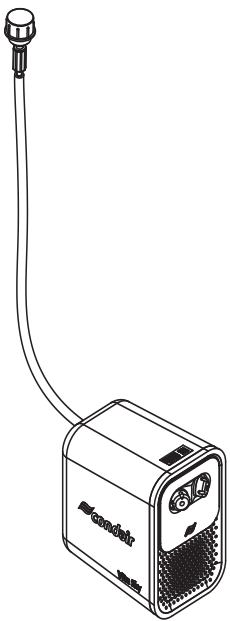
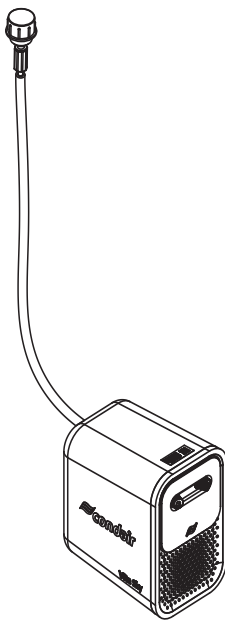
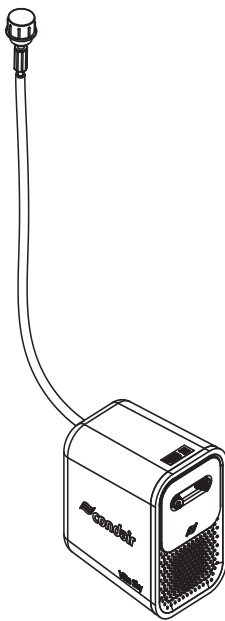
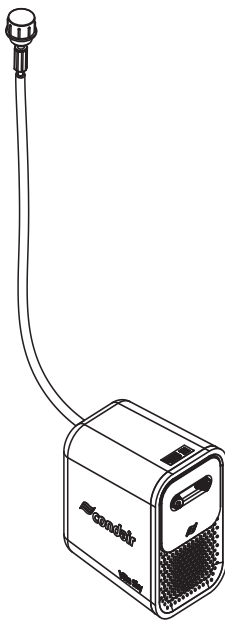

Fig. 3: Structure of the Condair Vita Sky M1 and Condair Vita Sky M2 nebulizers (figure shows Condair Vita Sky M1 nebulizer on the left and Condair Vita Sky M2 nebulizers in the middle and on the right)

#### Key

- |   |   |   |   |
|---|---|---|---|
| 1 | Condair Vita Sky M1 / Condair Vita Sky M2 nebulizer                                     | 6 | Wall bracket for mounting and alignment of the nebulizer.             |
| 2 | High-pressure nozzle(s)   | 7 | Ceiling bracket for mounting and alignment of the nebulizer           |
| 3 | Fan outlet opening  | 8 | Ceiling bracket "Premium" for mounting and alignment of the nebulizer |
| 4 | Power supply connector  |   |   |
| 5 | High pressure hose with quick coupling for hydraulic connection to ring or string line. |   |   |

### 3.4.2 Versions of the Condair Vita Sky M1 and Condair Vita Sky M2 nebulizers

	Condair Vita Sky M1			Condair Vita Sky M2		
						
Humidification capacity	2.5 l/hr	1.5 l/hr	2.5 l/hr	5 l/hr	3 l/hr	5 l/hr
Nozzle type	Diva L	Multitech 1.5	Multitech 2.5	Diva L	Multitech 1.5	Multitech 2.5
Number of nozzles	1			2		
High pressure line type	Ring line	String line		Ring line	String line	
High pressure connector	M16					
Voltage	24 VDC					
Power consumption	6 W	2 W		6 W	2 W	
Dimensions (H x W x D)	140 mm x 89 mm x 128 mm					
Weight	0.7 kg			0.9 kg		
Operating pressure	approx. 70 bar					
Ambient temperature	7...35 °C					
Ambient humidity	max. 95 %					
Protection class	IP20					

### 3.4.3 Accessories for Condair Vita Sky M1 and Condair Vita Sky M2 nebulizers

Some of the following parts and spare parts may only be available in selected markets. Contact your local Condair representative for more information on pricing and lead times.

Item
Wall bracket for wall mounting of the Condair Vita Sky M1 and Condair Vita Sky M2 nebulizers
Ceiling bracket for ceiling mounting of the Condair Vita Sky M1 and Condair Vita Sky M2 nebulizers
Ceiling bracket "Premium" for ceiling mounting of the Condair Vita Sky M1 and Condair Vita Sky M2 nebulizers

### 3.5 Condair Vita Sky T1 and Condair Vita Sky T2 nebulizers

#### 3.5.1 Structure of the Condair Vita Sky T1 and Condair Vita Sky T2 nebulizers

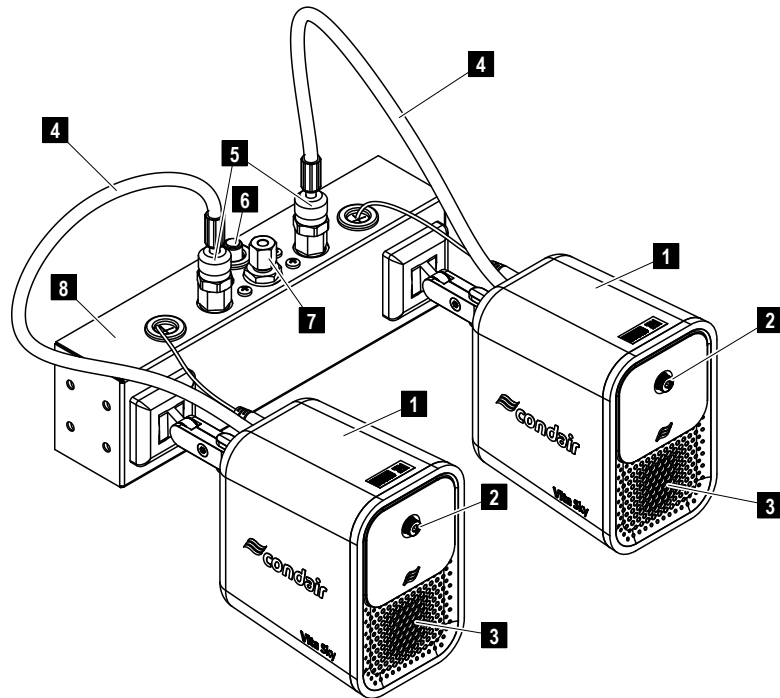
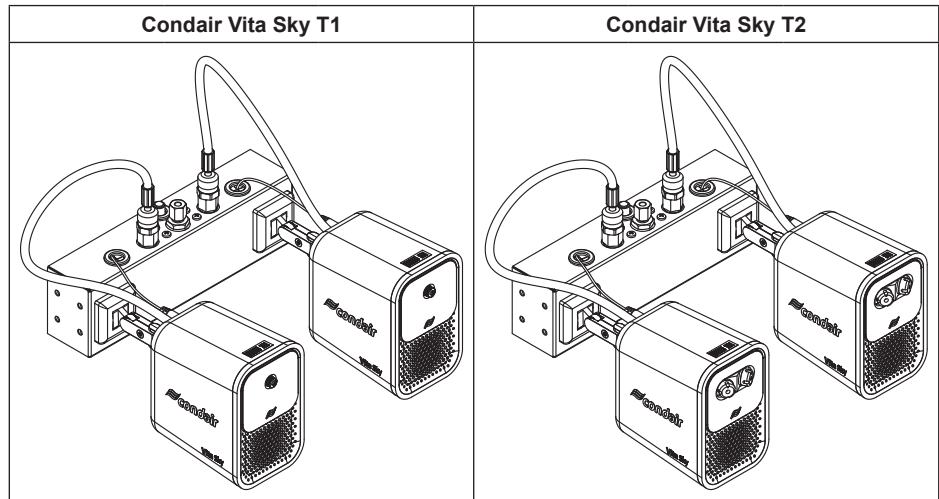

Fig. 4: Structure of the Condair Vita Sky T1 and Condair Vita Sky T2 nebulizers (figure shows Condair Vita Sky T2 nebulizer)

#### Key

- |   |  |   |  |
|---|--|---|--|
| 1 | Condair Vita Sky T1 / Condair Vita Sky T2 nebulizer                        | 5 | High pressure connectors with quick coupling for high pressure hoses of the nebulizers |
| 2 | High-pressure nozzle(s)  | 6 | Power supply connector   |
| 3 | Fan outlet opening   | 7 | High pressure water supply connector   |
| 4 | High pressure hose with quick coupling for hydraulic connection to bracket | 8 | Two-arm wall bracket with connections for the electrical and hydraulic supply          |

### 3.5.2 Versions of the Condair Vita Sky T1 and Condair Vita Sky T2 nebulizers



Humidification capacity	5 l/hr	3 l/hr	5 l/hr	10 l/hr	6 l/hr	10 l/hr
Nozzle type	Diva L	Multitech 1.5	Multitech 2.5	Diva L	Multitech 1.5	Multitech 2.5
Number of nozzles	2			4		
High pressure line type	Ring line	String line		Ring line	String line	
High pressure connector	M16					
Voltage	24 VDC					
Power consumption	12 W	4 W		12 W	4 W	
Dimensions (H x W x D)	140 mm x 299 mm x 265.5 mm					
Weight	3.5 kg			3.5 kg		
Operating pressure	approx. 70 bar					
Ambient temperature	7...35 °C					
Ambient humidity	max. 95 %					
Protection class	IP20					

### 3.6 Condair Vita Stream nebulizer

#### 3.6.1 Structure of the Condair Vita Stream nebulizer

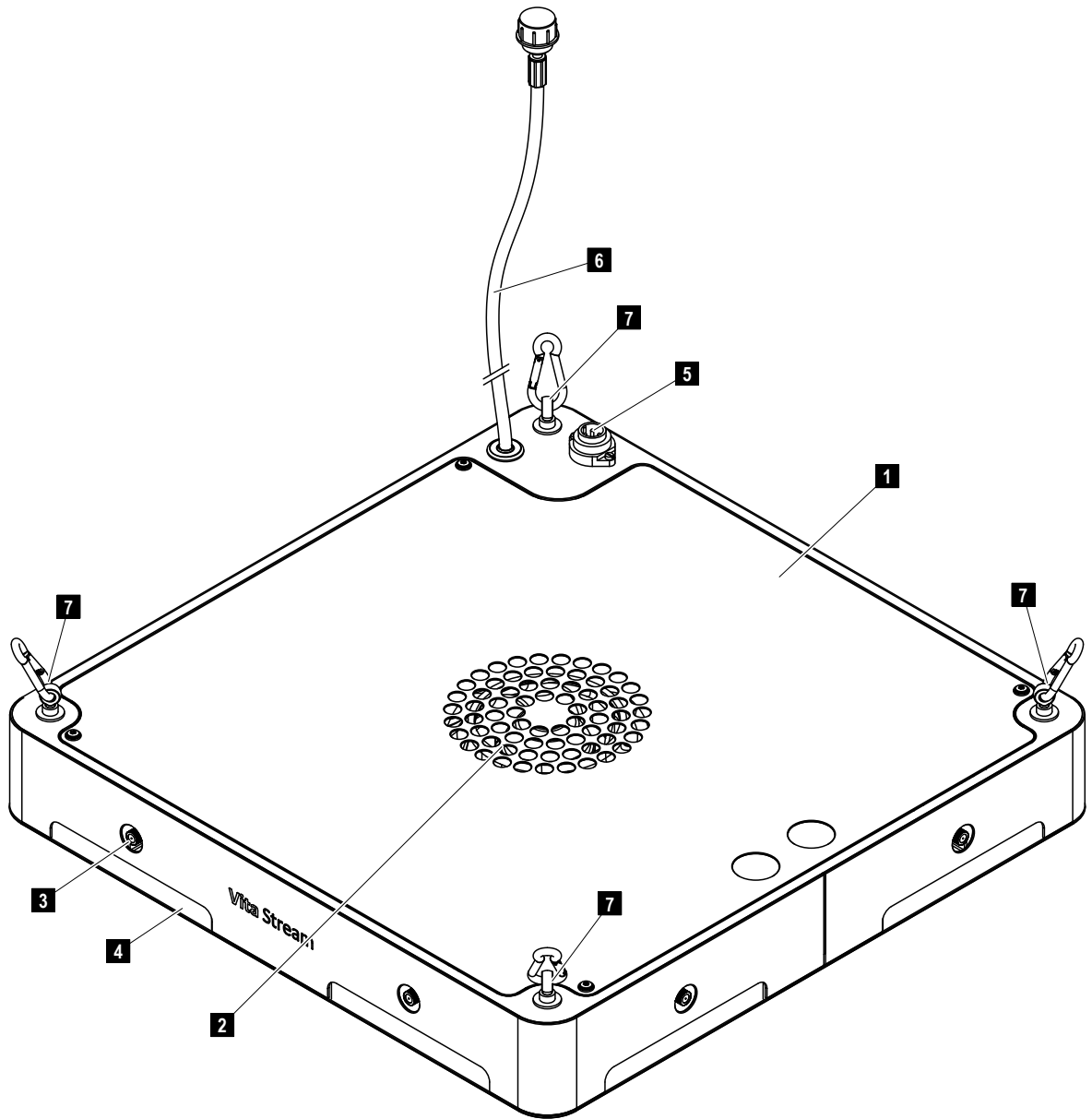
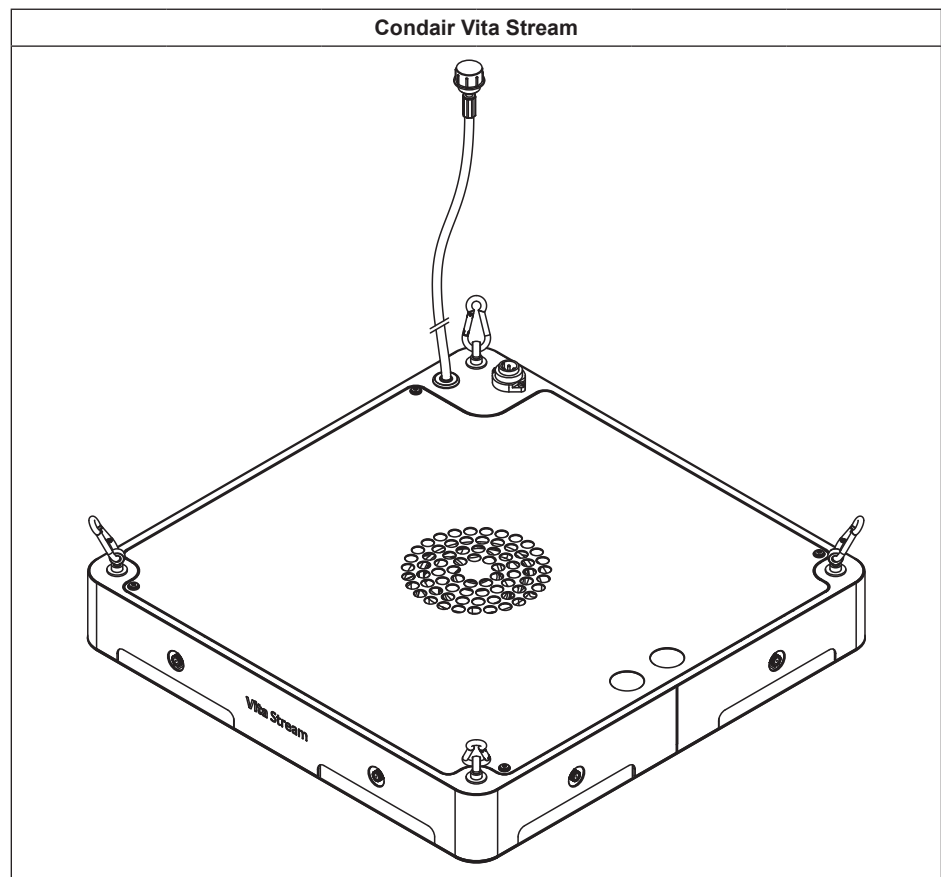

Fig. 5: Structure of the nebulizer Condair Vita Stream

#### Key

- |   |                               |   |   |
|---|-------------------------------|---|---|
| 1 | Nebulizer Condair Vita Stream | 5 | Power supply connector  |
| 2 | Fan inlet opening             | 6 | High pressure hose with quick coupling for hydraulic connection to ring or string line. |
| 3 | High-pressure nozzles (8 pcs) | 7 | Eyelets with snap hooks for fastening the chains/ropes for ceiling installation         |
| 4 | Fan outlet opening            |   |   |

### 3.6.2 Versions of the Condair Vita Stream nebulizer



Humidification capacity	20 l/hr	20 l/hr	36 l/hr	20 l/hr	20 l/hr	36 l/hr
Nozzle type	Multitech 2.5	Diva L	Multitech 4.5	Multitech 2.5	Diva L	Multitech 4.5
Number of nozzles	8					
High pressure line type	Ring line			String line		
High pressure connector	M16					
Voltage	115V AC / 230V AC					
Power consumption	35 VA			25 VA		
Dimensions (H x W x D)	73.5 mm x 500 mm x 500 mm					
Weight	10 kg					
Operating pressure	approx. 70 bar					
Ambient temperature	7...35 °C					
Ambient humidity	max. 95 %					
Protection class	IP20					

### 3.6.3 Accessories for Condair Vita Stream nebulizers

Some of the following parts and spare parts may only be available in selected markets. Contact your local Condair representative for more information on pricing and lead times.

Item
Chain 50 m
Stainless steel wire for ceiling suspension of the Condair Vita Stream nebulizer.
Crimp sleeve for steel cable D2 Cable tensioner for steel cable, open type M5/d8
Additional snap hook for ceiling mounting
Blind nozzle
Nozzle swivel adapter
Extension for nozzle swivel adapter

## 3.7 Condair Vita Line nebulizer

### 3.7.1 Structure of the Condair Vita Line nebulizer

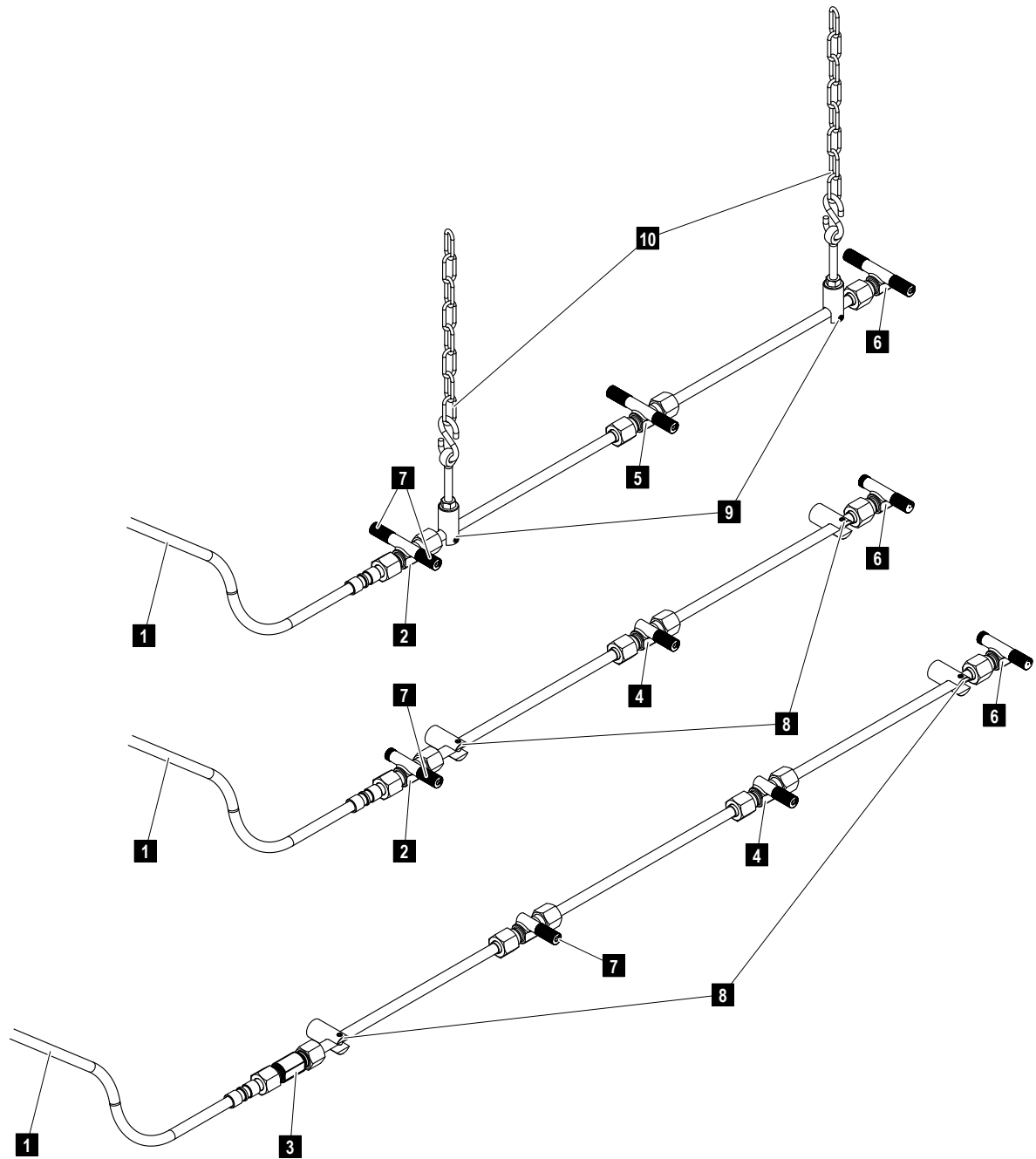
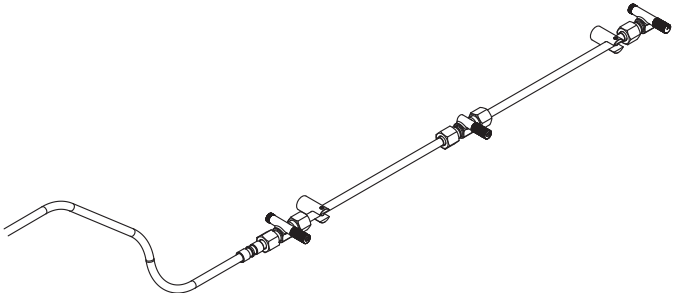

Fig. 6: Structure of the nebulizer Condair Vita Line

#### Key

- |  |  |
|--|--|
| 1 High-pressure hose for hydraulic connection to string line | 6 End piece for 1 or 2 nozzles                     |
| 2 Hose connection for 1 or 2 nozzles                         | 7 High-pressure nozzles                            |
| 3 Hose connection without nozzles                            | 8 Fixing brackets for wall mounting                |
| 4 T-piece for 1 nozzle                                       | 9 Fixing brackets with eyelet for ceiling mounting |
| 5 T-piece for 2 nozzles                                      | 10 Suspension (stainless steel chain)              |





### 3.7.2 Versions of the Condair Vita Line nebulizer

Condair Vita Line			
			
Humidification capacity	max. 180 l/hr	max. 175 l/hr	max. 180 l/hr
Nozzle type	Multitech 1.5	Multitech 2.5	Multitech 4.5
Number of nozzles	max. 120	max. 70	max. 40
High pressure line type	String line		
High pressure connector	8L		
Dimensions	Dependent on system layout		
Weight	approx. 250 g/m		
Material	Stainless steel 1.4307 (X2CrNi18-9)		
Operating pressure	approx. 70 bar		
Ambient temperature	7...35 °C		
Ambient humidity	max. 95 %		

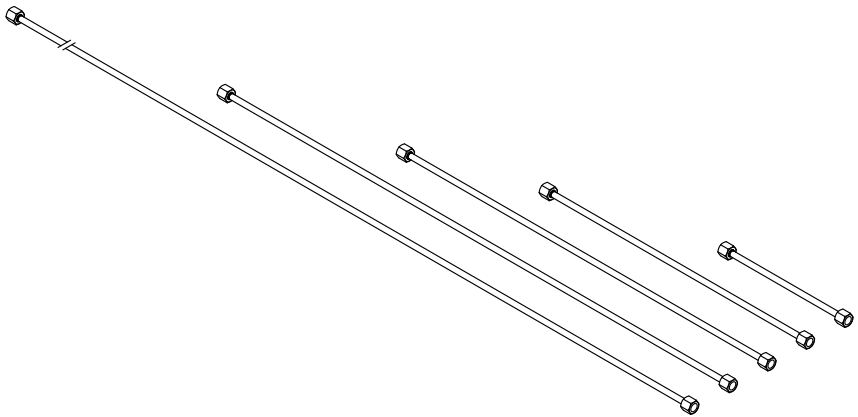
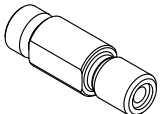
### 3.7.3 Components for Condair Vita Line nebulizers

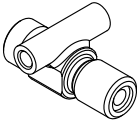
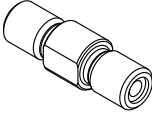
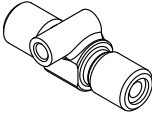
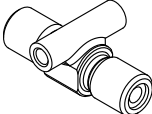
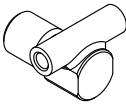
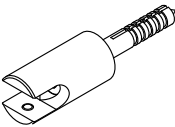
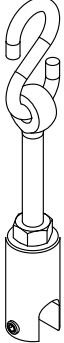
Some of the following components and spare parts may only be available in selected markets. Contact your local Condair representative for more information on pricing and lead times.

Item	
Standard pipes 0.25 m 0.50 m 0.75 m 1.00 m 2.00 m	
Hose connection without nozzles Cone/Flat connection	

Item	
Hose connection double nozzle Cone/Flat connection	
Connection piece without nozzles Flat/Flat connection	
T-piece single nozzle Flat/Flat connection	
T-piece double nozzles Flat/Flat connection	
End piece with double nozzles Flat connection	
Wall fixture	
Ceiling fixture	
Multitech nozzle 1.5 l/hr	
Multitech nozzles 2.5 l/hr 4.5 l/hr	
Blind nozzle stainless steel	
Nozzle swivel adapter	
O-ring for standard pipes	
Chain 50 m	

### 3.8 Condair Vita Space nebulizer

#### 3.8.1 Structure of the Condair Vita Space

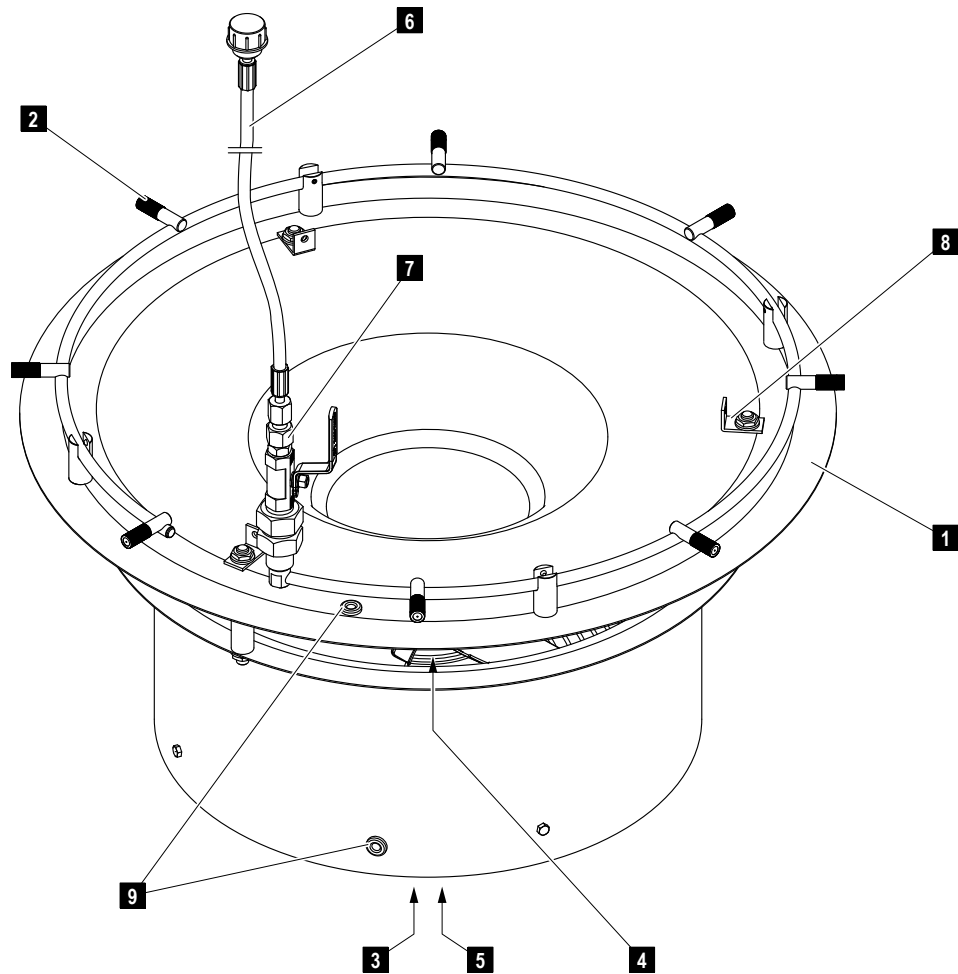
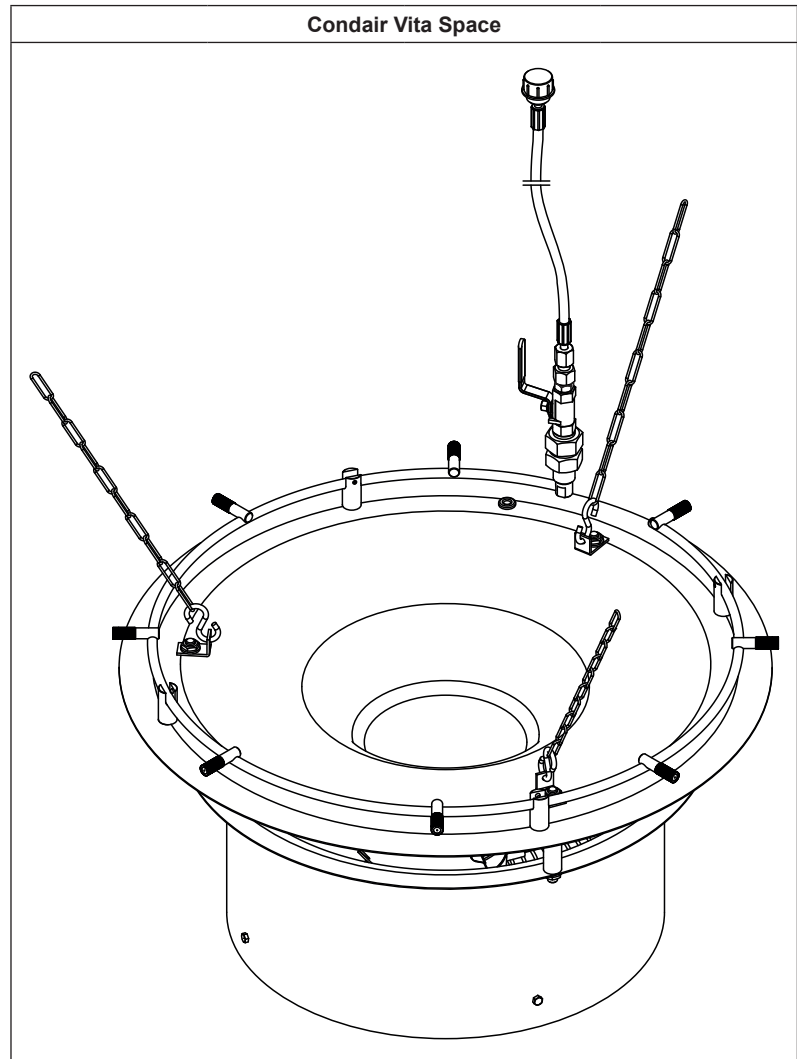

Fig. 7: Structure of the Condair Vita Space

#### Legend

- |   |  |   |   |
|---|--|---|---|
| 1 | Condair Vita Space nebulizer                               | 7 | 45° Cone Adapter - 6L                                 |
| 2 | High-pressure nozzles (max. 8 pcs)                         | 8 | Eyelets for attaching the chains for ceiling mounting |
| 3 | Air inlet opening  | 9 | Cable grommets for power supply cable                 |
| 4 | Air outlet opening   |   |   |
| 5 | Connection box power supply                                |   |   |
| 6 | High-pressure hose for hydraulic connection to string line |   |   |

### 3.8.2 Versions of the Condair Space nebulizer



Humidification capacity	12 l/h	20 l/h	36 l/h	52 l/h
Nozzle type	Multitech 1.5	Multitech 2.5	Multitech 4.5	Multitech 6.5
Number of nozzles	8			
High pressure line type	String line			
High pressure connector	M16			
Voltage	115V AC / 230V AC			
Power consumption	26 W (12 - 36 l/h / 49 W (>36 l/h))			
Dimensions (H x Ø)	302 mm x ø540 mm			
Weight	5.5 kg			
Operating pressure	approx. 70 bar			
Ambient temperature	7...35 °C			
Ambient humidity	max. 95 %rh			
Protection class	IP44			

The Condair Vita Space is hydraulically connected to the Condair Vita Direct room air humidification system using an "45° Cone Adapter - 6L".

Item
Vita Space Spray Head, 230V
Vita Space Spray Head, 115V UL
45° Cone Adapter - 6L

### 3.8.3 Accessories for Condair Vita Space nebulizers

Item
Wall bracket including air baffle
Chain 50 m
S-hook
Multitech nozzle 1.5 l/hr
Multitech nozzle 2.5 l/hr
Multitech nozzle 4.5 l/hr
Multitech nozzle 6.5 l/hr
Blind nozzle stainless steel
Nozzle swivel adapter
Snap hook 50 x ø5 mm

### 3.9 Zone valves

The zone valves for controlling nebulizers in branch line systems are available in three different versions for different flow rates.

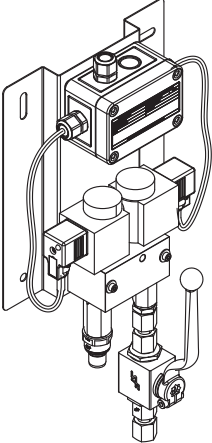
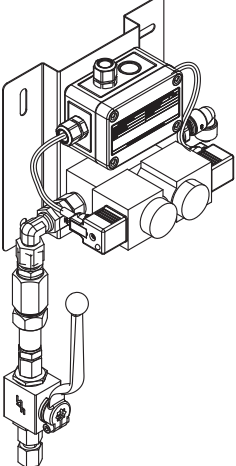
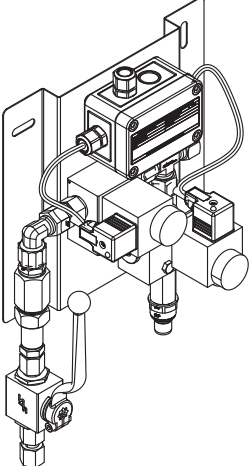
<b>Zone valve 76I</b>																	
	<table> <tr><td>Flow range</td><td>0 - 76 l/h</td></tr> <tr><td>Inlet fitting</td><td>10 L</td></tr> <tr><td>Outlet fitting</td><td>8 L</td></tr> <tr><td>Drain connection</td><td>JG 6</td></tr> <tr><td>Integrated filter</td><td>80 µm</td></tr> <tr><td>Valve type</td><td>3/2-way valve</td></tr> <tr><td>Coil voltage</td><td>24 VDC</td></tr> <tr><td>Power consumption</td><td>32 W</td></tr> </table>	Flow range	0 - 76 l/h	Inlet fitting	10 L	Outlet fitting	8 L	Drain connection	JG 6	Integrated filter	80 µm	Valve type	3/2-way valve	Coil voltage	24 VDC	Power consumption	32 W
Flow range	0 - 76 l/h																
Inlet fitting	10 L																
Outlet fitting	8 L																
Drain connection	JG 6																
Integrated filter	80 µm																
Valve type	3/2-way valve																
Coil voltage	24 VDC																
Power consumption	32 W																
<b>Zone valve 60-360L</b>																	
	<table> <tr><td>Flow range</td><td>60 - 360 l/h</td></tr> <tr><td>Inlet fitting</td><td>10 L</td></tr> <tr><td>Outlet fitting</td><td>8 L</td></tr> <tr><td>Drain connection</td><td>JG 6</td></tr> <tr><td>Integrated filter</td><td>80 µm</td></tr> <tr><td>Valve type</td><td>3/2-way valve</td></tr> <tr><td>Coil voltage</td><td>24 V</td></tr> <tr><td>Power consumption</td><td>32 W</td></tr> </table>	Flow range	60 - 360 l/h	Inlet fitting	10 L	Outlet fitting	8 L	Drain connection	JG 6	Integrated filter	80 µm	Valve type	3/2-way valve	Coil voltage	24 V	Power consumption	32 W
Flow range	60 - 360 l/h																
Inlet fitting	10 L																
Outlet fitting	8 L																
Drain connection	JG 6																
Integrated filter	80 µm																
Valve type	3/2-way valve																
Coil voltage	24 V																
Power consumption	32 W																
<b>Zone valve 120-1800L</b>																	
	<table> <tr><td>Flow range</td><td>120 - 1800 l/h</td></tr> <tr><td>Inlet fitting</td><td>10 L</td></tr> <tr><td>Outlet fitting</td><td>12 L</td></tr> <tr><td>Drain connection</td><td>JG 6</td></tr> <tr><td>Integrated filter</td><td>80 µm</td></tr> <tr><td>Valve type</td><td>3/2-way valve</td></tr> <tr><td>Coil voltage</td><td>24 V</td></tr> <tr><td>Power consumption</td><td>32 W</td></tr> </table>	Flow range	120 - 1800 l/h	Inlet fitting	10 L	Outlet fitting	12 L	Drain connection	JG 6	Integrated filter	80 µm	Valve type	3/2-way valve	Coil voltage	24 V	Power consumption	32 W
Flow range	120 - 1800 l/h																
Inlet fitting	10 L																
Outlet fitting	12 L																
Drain connection	JG 6																
Integrated filter	80 µm																
Valve type	3/2-way valve																
Coil voltage	24 V																
Power consumption	32 W																

## 3.10 Control devices

### 3.10.1 System Master

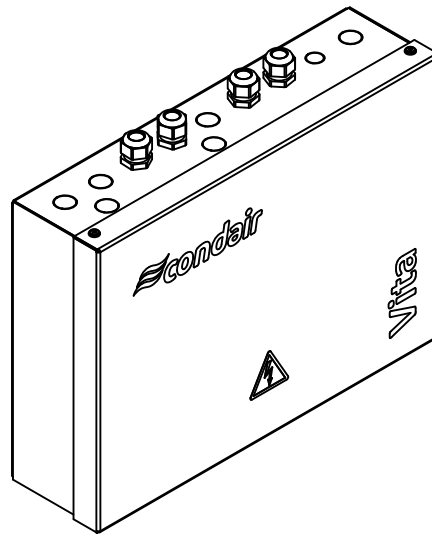

The System Master is mounted on the frame of the Condair Vita high-pressure water treatment systems. It serves as a digital control for monitoring and analyzing the entire humidification system including the high pressure water treatment system, the nebulizers and the humidification zones. The System Master contains extensive reporting, hygiene, data logging and service functions. The connection and data transfer to a building management system via LAN with Modbus or BACnet is possible.

The System Master is connected to the control devices (HumPower, HumSpot, Industrial sensor gateway and CAN bus extender) of the humidification zones via the CAN bus.

### 3.10.2 External control unit

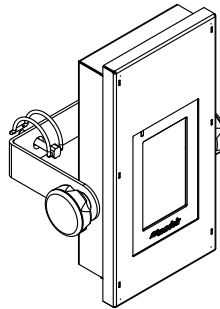

The external control unit is connected to the System Master and forms the central access point to the high pressure water treatment system and zone control. The external control unit shows current information of the high pressure water treatment system, reports errors and maintenance instructions and offers update and analysis functions via the integrated USB interface. In addition, the parameters of all humidification zones can be accessed and adjusted via the external control unit.

### 3.10.3 HumPower

The HumPower provides the operating voltage for the nebulizers, the junction boxes and the HumPower 24V. Please refer to the installation overviews and information on system limitations in [Section 4](#).

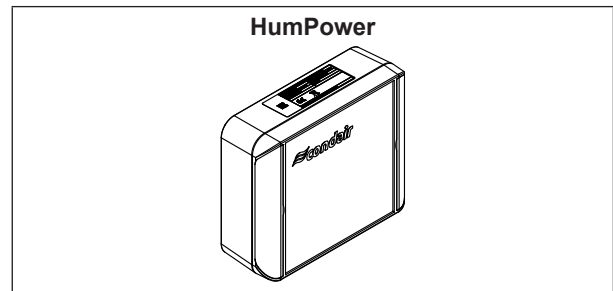

Dimensions (L x H x D)	180 mm x 150 mm x 60 mm
Input voltage range	120 -240 VAC, 1~, 50/60 Hz
Input voltage range	25-42 VDC (via CAN-Bus)
Power consumption	30 VA (AC)
Output voltage	120-240 VAC, 50/60 Hz (corresponds to input voltage range)
Output voltage	24 VDC
Output power / switching power	440 VA (AC)
Output power / switching power	20 W (DC)
Overvoltage category	III
Protection class	I
IP protection type	IP66
Ambient temperature	7 - 35 °C
Ambient humidity	Max. 80 %rH, non condensing

### 3.10.4 HumPower 24V

The HumPower 24 V has a 24VDC power supply and provides 24 V supply for the 24 V nebulizers (Condair Vita Sky) and the zone valves. Please refer to the installation overviews and information on system limitations in [Section 4](#).

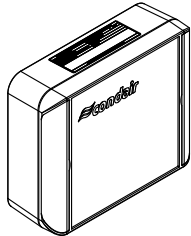
<b>HumPower 24V</b>	
	
Dimensions (L x H x D)	180 mm x 150 mm x 60 mm
Input voltage range	120 -240 VAC, 1~, 50/60 Hz
Power consumption	50 VA (AC)
Output voltage	24 VDC
Output power / switching power	50 W (DC)
Overvoltage category	III
Protection class	I
IP protection type	IP66
Ambient temperature	7 - 35 °C
Ambient humidity	Max. 80 %rH, non condensing

### 3.10.5 CAN bus extender

The maximum cable length of the CAN bus is limited to approx. 200 m. The maximum cable length of the CAN bus can be extended to approx. 400 m with one CAN bus extender and to ca. 600 m with two CAN bus extenders.

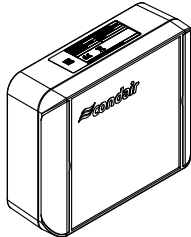
<b>CAN-Bus Extender</b>	
	
Dimensions (L x H x D)	180 mm x 150 mm x 60 mm
Input voltage range	120 -240 VAC, 1~, 50/60 Hz
Power consumption	30 VA (AC)
Overvoltage category	III
Protection class	I
IP protection type	IP66
Ambient temperature	7 - 35 °C
Ambient humidity	Max. 80 %rH, non condensing

### 3.10.6 Industrial sensor gateway with industrial humidity sensor

The industrial humidity sensor, together with the industrial sensor gateway, is used to measure the relative humidity and room temperature in the humidification zone. It is used when the humidification values of a humidification area need to be measured very precisely. The industrial sensor gateway is connected to the humidification area via CAN bus.

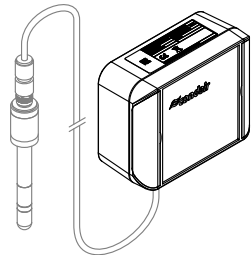
<b>Industrial sensor gateway</b>	
	
Dimensions (L x H x D)	140 mm x 140 mm x 60 mm
Input voltage range	up to 42 VDC
Power consumption	2.5 W (DC)
Interfaces	2x CANOpen
	2x Analog input industrial sensor (4-20 mA / 0-100 °C / 0-100 %rH)
	1x Analog input (4-20 mA / Setpoint %rH / 0-100 %rH)
	On/Off Demand
	On/Off Release
IP protection type	IP66
Ambient temperature	7 - 35 °C
Ambient humidity	Max. 80 %rH, non-condensing

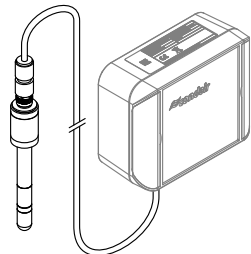
<b>Industrial humidity sensor</b>	
	
Dimensions (L x D1 x D2)	148.5 mm x 12.8 mm x 24.4 mm
Input voltage range	12 - 30 VDC
Power consumption	0.5 W (DC)
Interfaces	1x Analog output (4-20 mA / 0-100 °C)
	1x Analog output (4-20 mA / 0-100 %rH)
Tolerance, typical (25 °C)	±3.5 %rH / ±0.6 °C
Tolerance, across the entire temperature range	±4.5 %rH / ±0.6 °C
IP protection type	??
Ambient temperature	7 - 35 °C
Ambient humidity	Max. 100 %rH, non-condensing

### 3.10.7 HumSpot

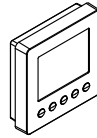

The HumSpot is used for precise, digital control of the air humidification in the humidification areas. One HumSpot or several HumSpots can be used per humidification area. The HumSpot(s) are connected to the HumPower of the respective humidification zone via the CAN bus. The relative humidity and room temperature are permanently displayed via the HumSpot(s). In addition, the HumSpot(s) offers the possibility of displaying system warnings and errors.

### 3.10.8 Safety humidistat

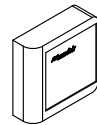

The safety humidistat serves as a safety device. It is set to a maximum humidity setpoint to prevent the humidification area from becoming overhumidified. The safety humidistat can also be used to control the zone with on/off operation.

### 3.10.9 Junction Box

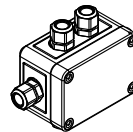

The junction box is used for the electrical connection of the HumPower and HumPower 24V as well as to electrically connect multiple nebulizers.

# 4 Installation overviews

## 4.1 Installation example "Ring line"

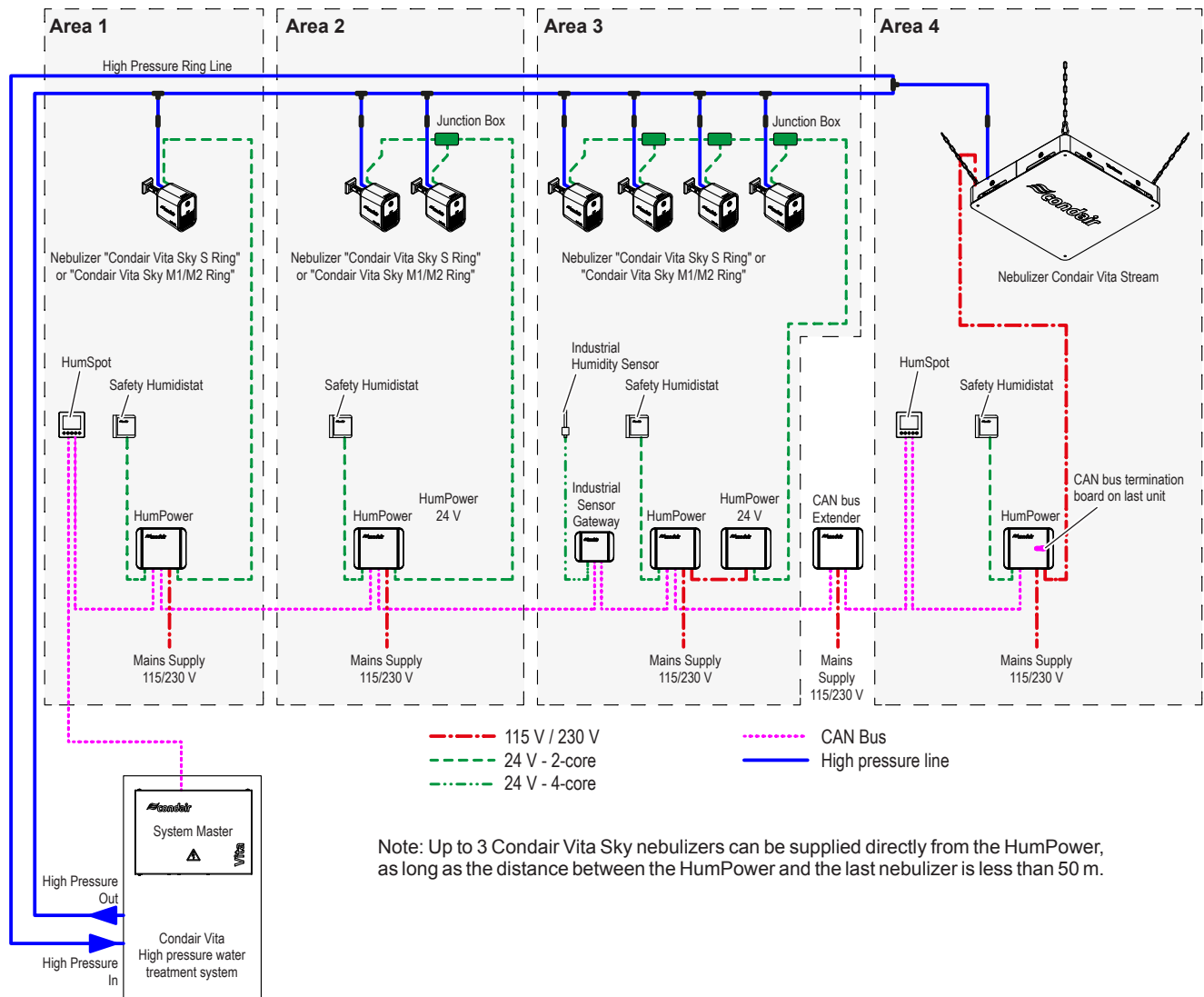

Fig. 8: Installation example "Ring line"

## 4.2 Installation examples "String line"

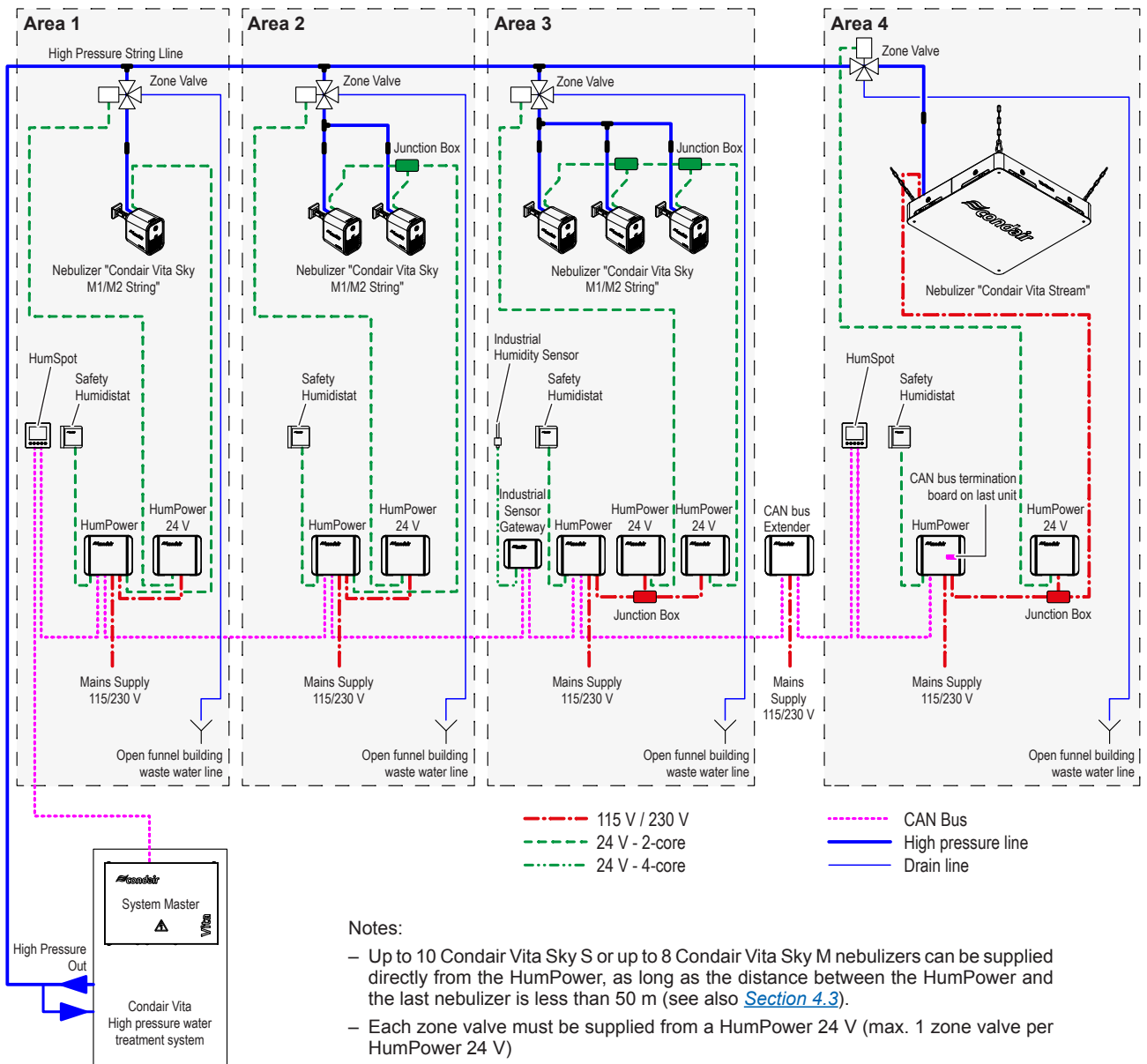

Fig. 9: "String line" installation example 1

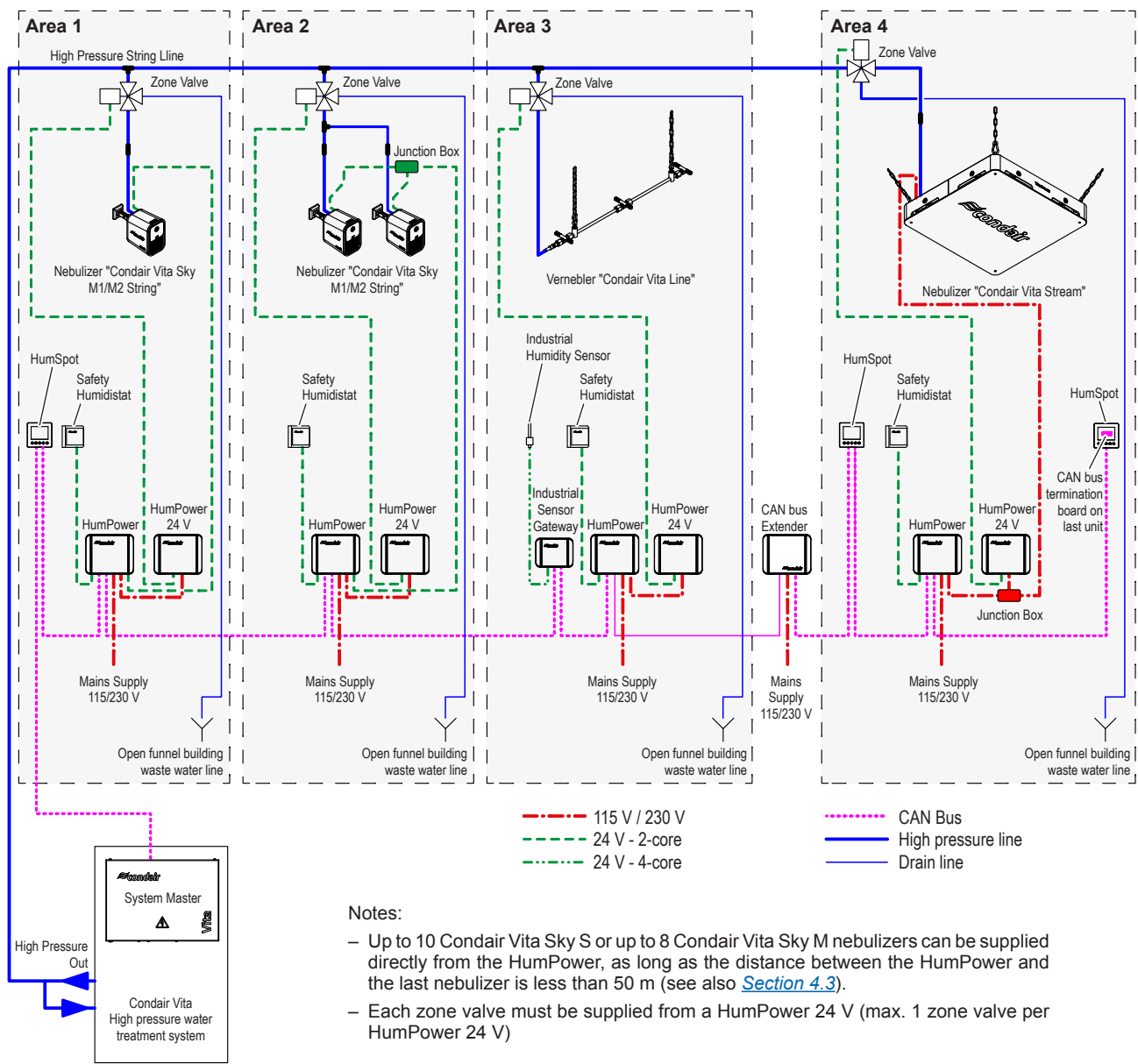

Fig. 10: "String line" installation example 2

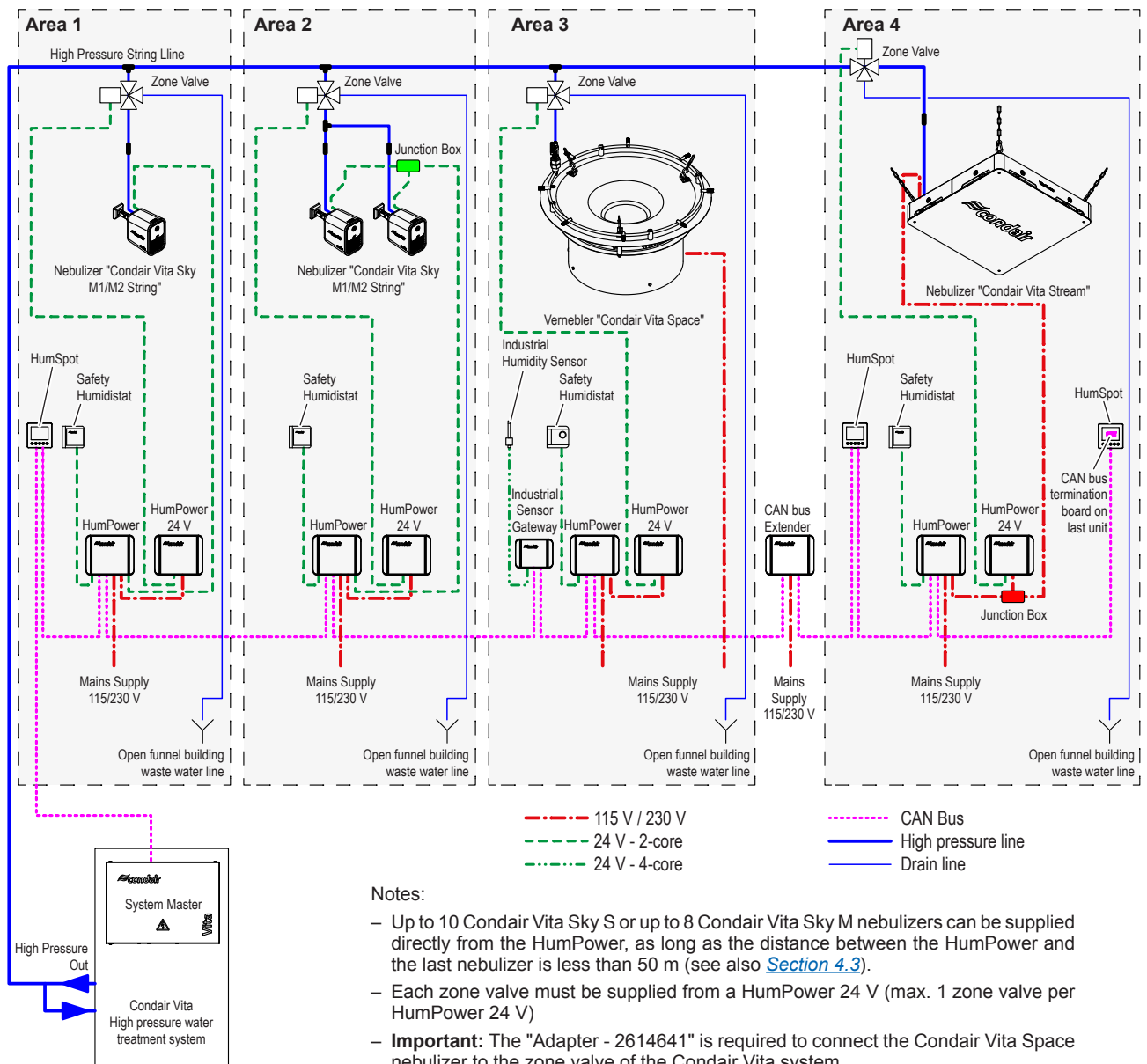

Fig. 11: "String line" installation example 3

## 4.3 System Restrictions

### 4.3.1 CAN bus system limitations

The following maximum values must not be exceeded in the humidification system:

Max. Areas	50
Max. CAN bus Nodes	126 System Master + Total number of HumPowers + Total number of HumSpots + Total number of Industrial Sensor Gateways + Total number of CAN bus extenders must be $\leq 126$
Max. CAN bus extenders	2
Max. CAN bus length	approx. 200 m approx. 400 m (with one CAN bus extender) approx. 600 m (with two CAN bus extenders)

### 4.3.2 Max. number of nebulizers and max. number of HumPower 24 V per HumPower

	Ring line system	String line system
Nebulizer Condair Vita Stream 230 V	10	10
Nebulizer Condair Vita Stream 115 V	8	10
Nebulizer Condair Vita Sky S	3	–
Nebulizer Condair Vita Sky M	3	8
HumPower 24 V	3	3

### 4.3.3 Max. number of nebulizers per HumPower 24 V:

	Ring line system	String line system
Nebulizer Condair Vita Sky S	10	–
Nebulizer Condair Vita Sky M	8	20
Zone valve	-	1

<sup>1)</sup> Each zone valve must be connected to a separate HumPower 24V

# 5 Mounting

---

## 5.1 Mounting the nebulizers

### 5.1.1 General information on positioning

The following **information on positioning must be referred to and complied with:**

- There must be no deflector surfaces facing in the direction of the mist. Otherwise, condensation or precipitation – and therefore dripping water – may occur.
- In the direction of the mist, the airspace should be clear at an angle of 90° and a distance of 4 m.
- Within the specified free area (air space at the front, distance from ceiling and floor), there must not be any ventilation ducts, system components or other parts / goods sensitive to humidity.
- The stubs with the high-pressure hose 1/8" extending from the short T-connector (ring line) must not be longer than 4 m.
- The nebulizers must not be placed directly over workstations or machines. In workplaces, an impairment of the working environment due to evaporative cooling of the aerosols is to be expected. Machines and materials can be damaged in the event of malfunctions due to dripping water
- Safety devices such as fire detectors or alarm systems may react to aerosol mist under certain circumstances. Make sure that no such devices are mounted in the area of the aerosol mist.
- The evaporation distance (free air gap in front of the nebulizer) described in the following sections varies depending on the place of use, the prevailing temperature, the relative humidity and the air flow. The specifications are selected in such a way that the evaporation distance is not exceeded under expected conditions.
- Please also note the specific positioning instructions in the corresponding chapters of the respective nebulizers.

## 5.1.2 Positioning and mounting the Condair Vita Sky S/M1/M2 nebulizers

### 5.1.2.1 Positioning and mounting the Condair Vita Sky S/M1/M2 nebulizers

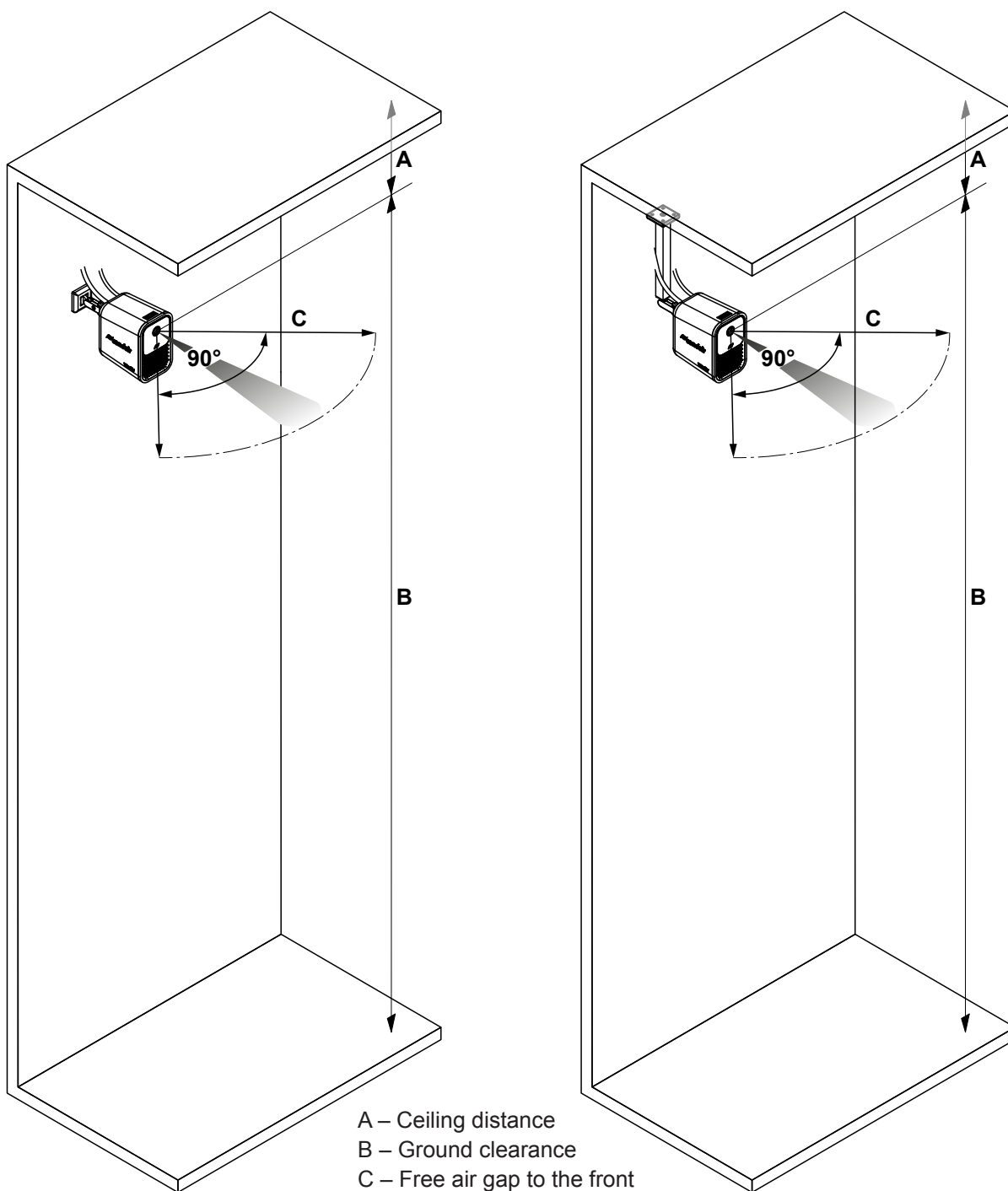

Fig. 12: Positioning and mounting the Condair Vita Sky S/M1/M2 nebulizers

Nebulizer type	Ceiling distance (A)	Ground clearance (B)	Free air gap (C)
Condair Vita Sky S	0.2 m	2.4 m	4.0 m
Condair Vita Sky M1	0.2 m	3.0 m	4.0 m
Condair Vita Sky M2	0.2 m	4.0 m	4.0 m

### 5.1.2.2 Wall mounting of the Condair Vita Sky S/M1/M2 nebulizers

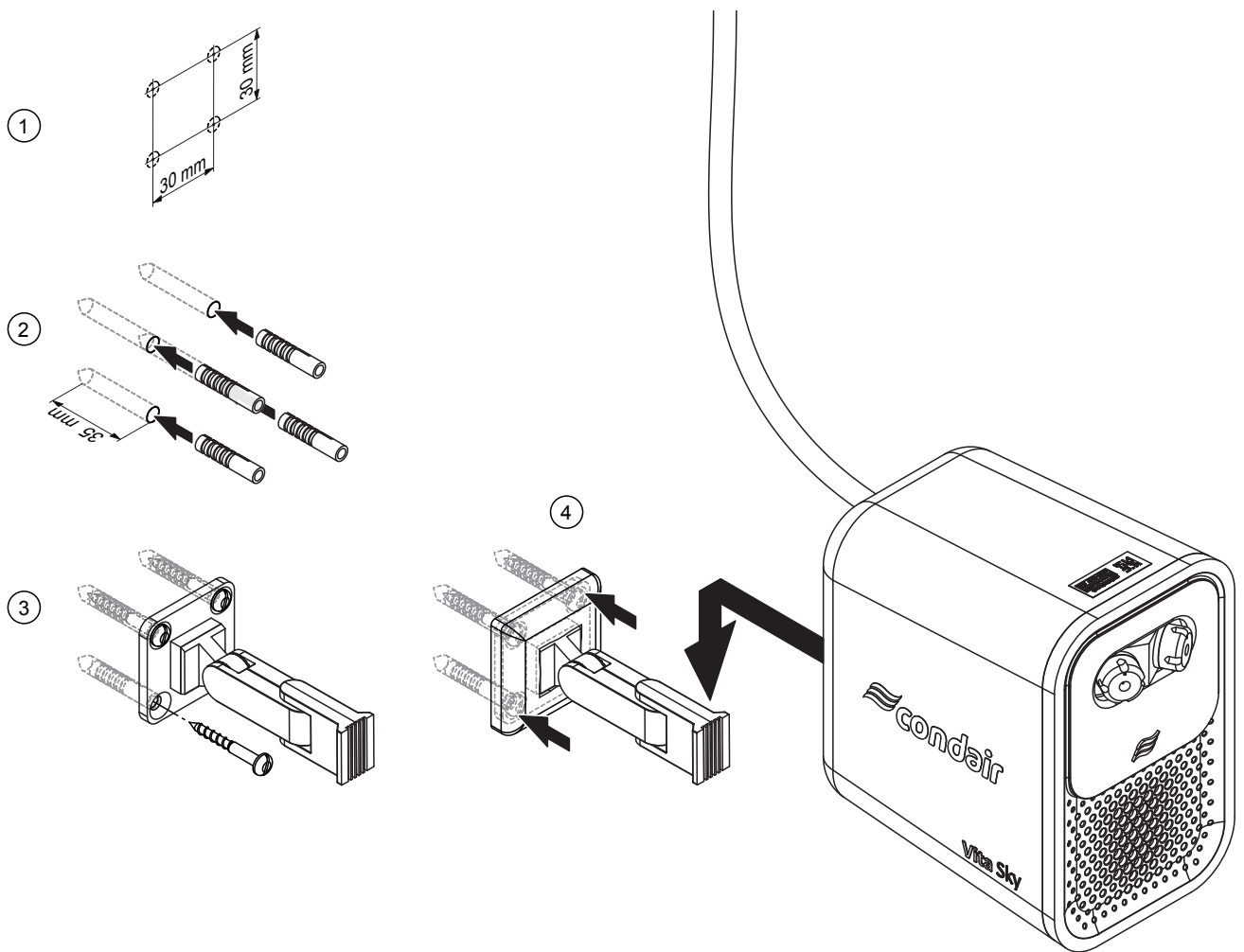

Fig. 13: Wall mounting of the Condair Vita Sky S/M1/M2 nebulizers (figure shows fastening with dowels)

#### Mounting:

1. Mark the 4 fixing points of the wall bracket at the desired location on the wall.
2. Drill 4 holes  $\varnothing 6 \times 35$  mm and insert dowels  $\varnothing 6 \times 30$  mm.  
Note: This step is not necessary if the wall bracket is mounted on a wooden or plaster wall.
3. Attach the wall bracket to the wall using 4 screws  $\varnothing 4 \times 35$  mm or suitable wood or plaster screws.
4. Slide the cover panel over the mounting flange until it stops. Hang the nebulizer in the wall bracket and slide it down until it stops.

### 5.1.2.3 Ceiling mounting of the Condair Vita Sky S/M1/M2 nebulizers with standard ceiling bracket

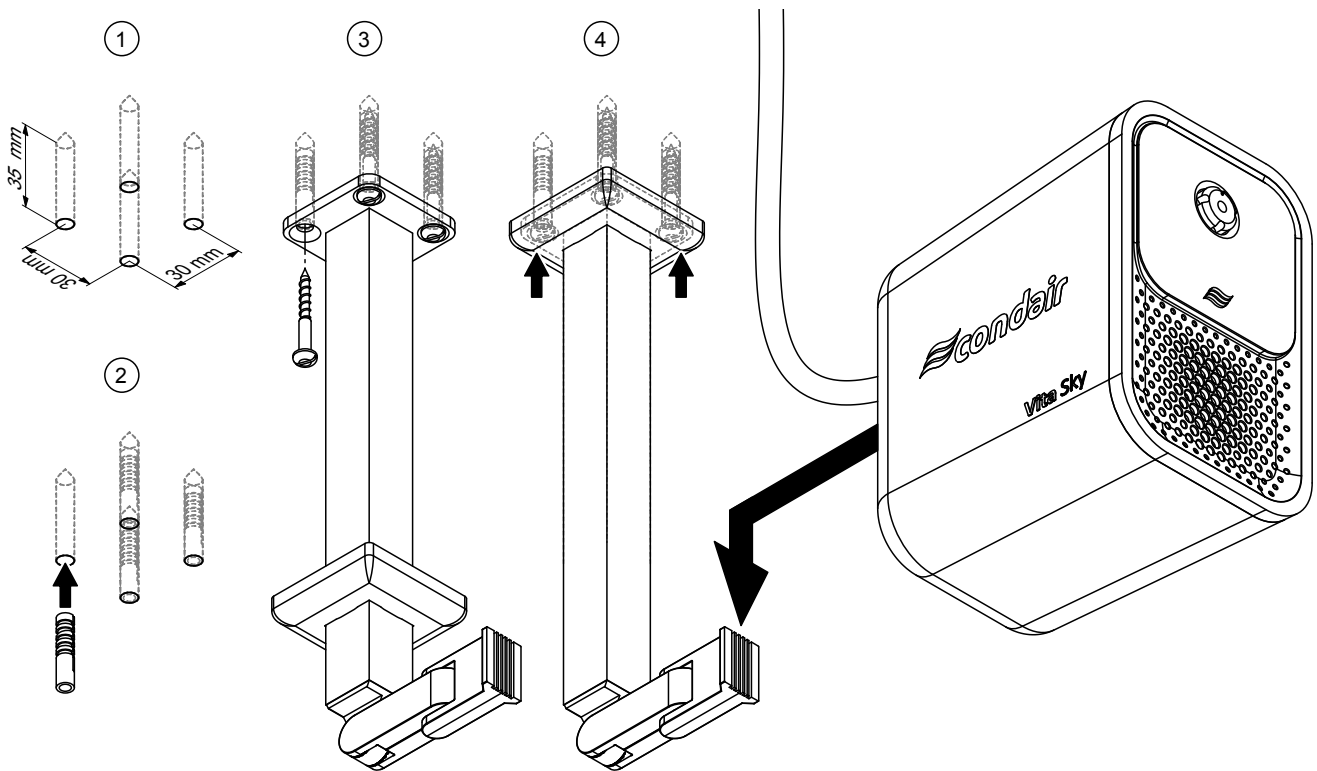

Fig. 14: Ceiling mounting of the Condair Vita Sky S/M1/M2 nebulizers with standard ceiling bracket (figure shows fastening with dowels)

#### Mounting:

1. Mark the 4 fixing points of the ceiling bracket at the desired location on the ceiling.
2. Drill 4 holes  $\varnothing 6 \times 35$  mm and insert dowels  $\varnothing 6 \times 30$  mm.  
Note: This step is not necessary if the ceiling bracket is mounted on a wooden or plaster ceiling.
3. Attach the ceiling bracket to the ceiling using 4 screws  $\varnothing 4 \times 35$  mm or suitable wood or plaster screws.
4. Push the cover panel upwards until it stops. Hang the nebulizer in the ceiling bracket and push it downwards until it stops.

### 5.1.2.4 Ceiling mounting of the Condair Vita Sky S/M1/M2 nebulizers with premium ceiling bracket

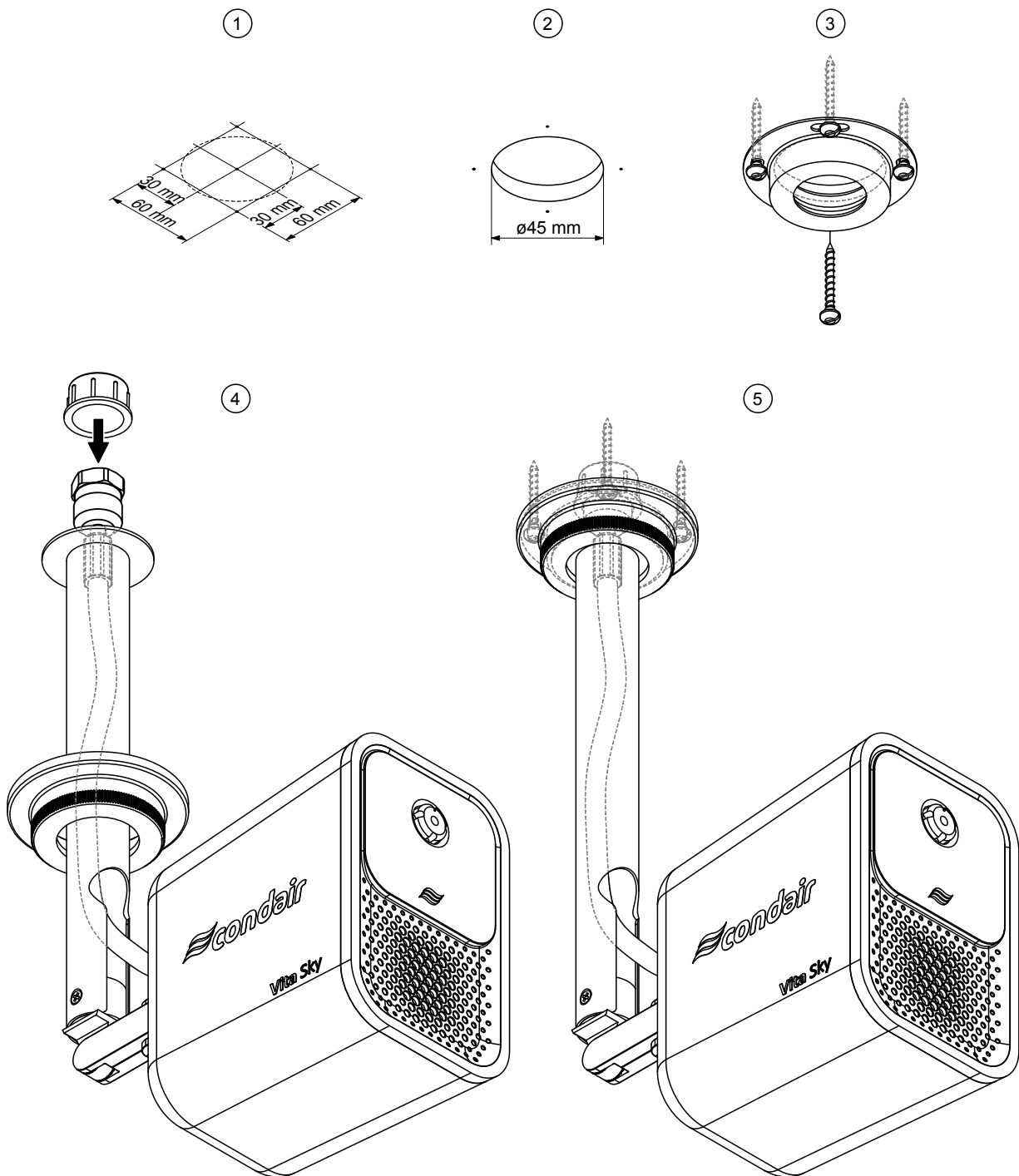

Fig. 15: Ceiling mounting of the Condair Vita Sky S/M1/M2 nebulizers with premium ceiling bracket (figure shows fastening to a suspended ceiling)

#### Mounting:

1. Mark the position of the hole for the feed-through of the hydraulic and electrical supply and 4 points for attaching the threaded flange at the desired location on the ceiling.
2. Drill a  $\varnothing 45$  mm hole into the suspended ceiling.
3. Fasten the threaded flange of the ceiling bracket to the ceiling using 4 screws  $\varnothing 4 \times 35$  mm or other suitable wood or plaster screws.
4. Remove the yellow cap from the high-pressure hose connection. Insert the nebulizer's high-pressure hose into the tube of the ceiling bracket and push it upwards. Then hang the nebulizer in the ceiling mount and push it down until it stops. Close the high-pressure hose connection again with the yellow cap.
5. Do not perform this step until you connect the nebulizer to the high-pressure system:
  - Remove the yellow cap on the nebulizer's high-pressure hose connection.
  - Connect the high-pressure hose to the high-pressure system. Route the 24 VDC power supply cable down the tube of the ceiling bracket and connect it to the nebulizer. Connect the ceiling bracket to the threaded flange using the knurled nut.

### 5.1.3 Positioning and mounting the Condair Vita Sky T1/T2 nebulizers

#### 5.1.3.1 Positioning the Condair Vita Sky T1/T2 nebulizers

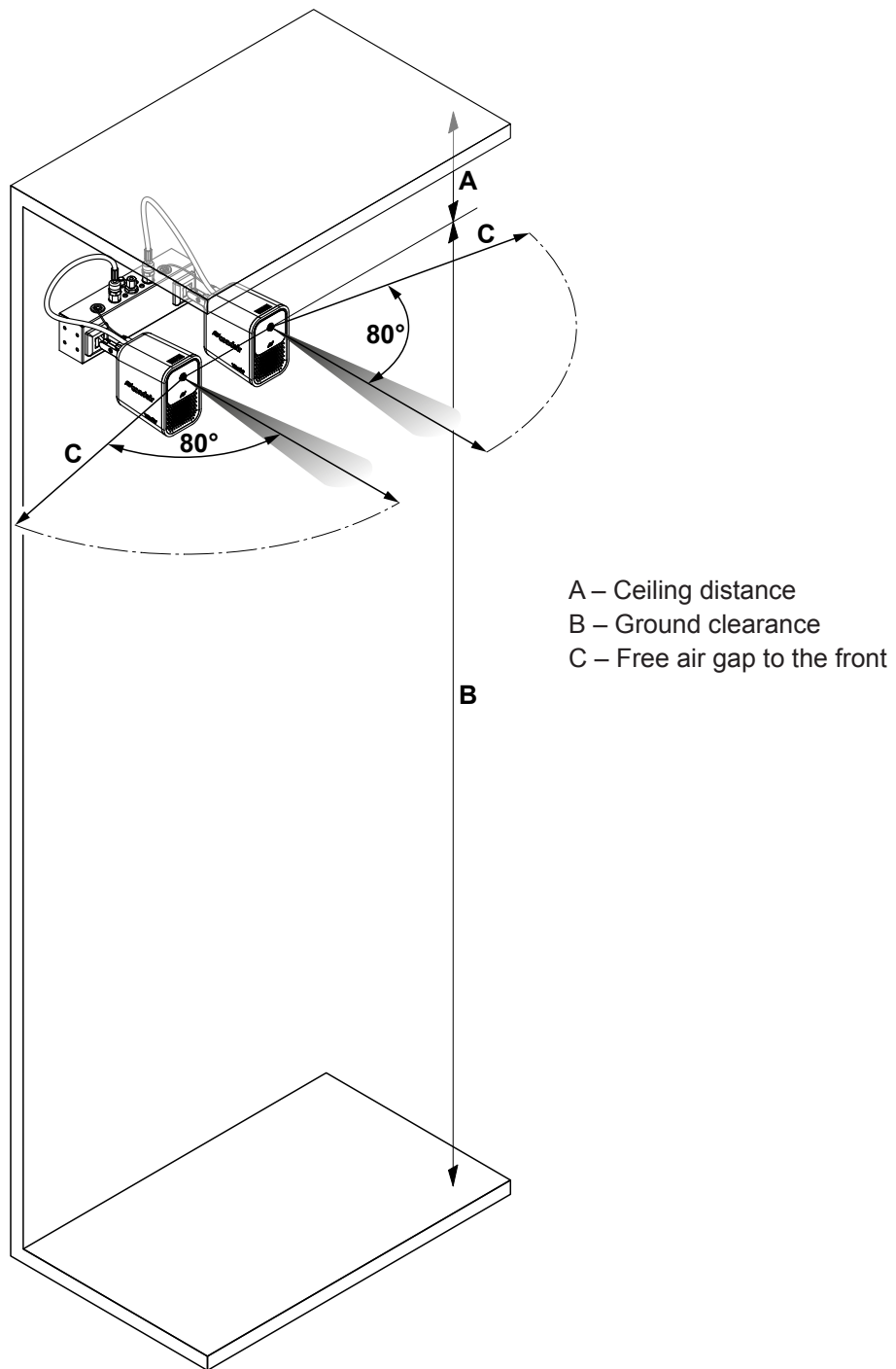

Fig. 16: Positioning and mounting the Condair Vita Sky T1/T2 nebulizers

Nebulizer type	Ceiling distance (A)	Ground clearance (B)	Free air gap (C)
Condair Vita Sky T1	0.5 m	3.0 m	4.0 m
Condair Vita Sky T2	1.0 m	4.0 m	4.0 m

### 5.1.3.2 Wall mounting of the Condair Vita Sky T1/T2 nebulizers

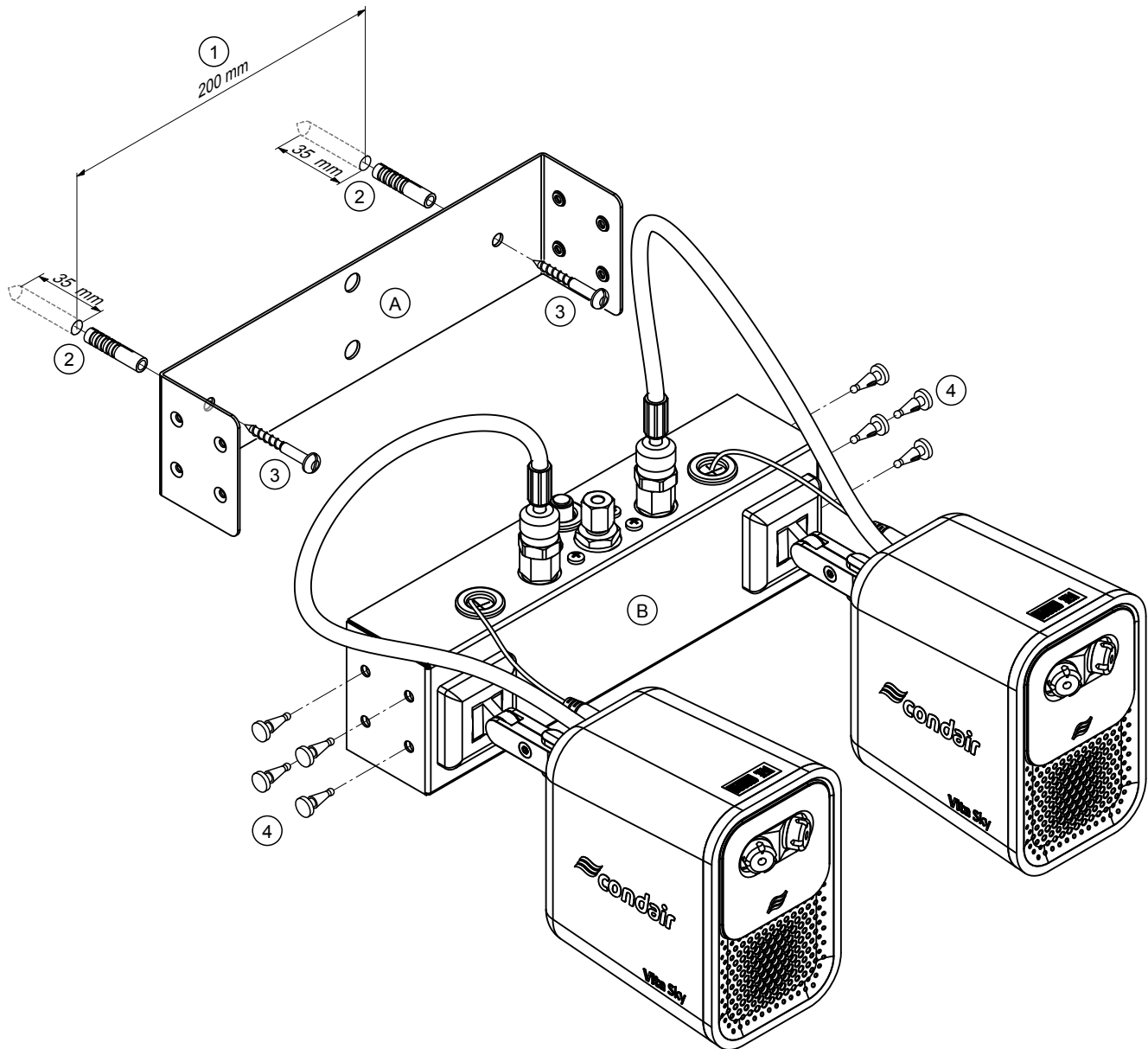

Fig. 17: Wall mounting of the Condair Vita Sky T1/T2 nebulizers (figure shows fastening with dowels)

#### Mounting:

1. Mark the 2 points for fastening the wall plate "A" at the desired location on the wall.
2. Drill 2 holes  $\varnothing 6 \times 35$  mm and insert dowels  $\varnothing 6 \times 30$  mm.  
Note: This step is not necessary if the wall plate "A" is mounted on a wooden or plaster wall.
3. Fasten wall plate "A" to the wall with 2 screws  $\varnothing 4 \times 35$  mm or suitable wood or plaster screws.
4. Insert nebulizer support "B" into the wall plate "A" and secure it with 4 locking pins on each side.

## 5.1.4 Positioning and mounting the Condair Vita Stream nebulizer

### 5.1.4.1 Additional information on positioning the Condair Vita Stream nebulizer

- The maximum installation height should not be exceeded so as to not make access unnecessarily difficult.
- The air space in front should be free at a 360° angle and a distance of 4 m. (For further details, see [Fig. 18](#))
- The stubs with the DN4 high-pressure hose, starting from the short T-connector, must not exceed 6 m in length.

### 5.1.4.2 Positioning the Condair Vita Stream nebulizer

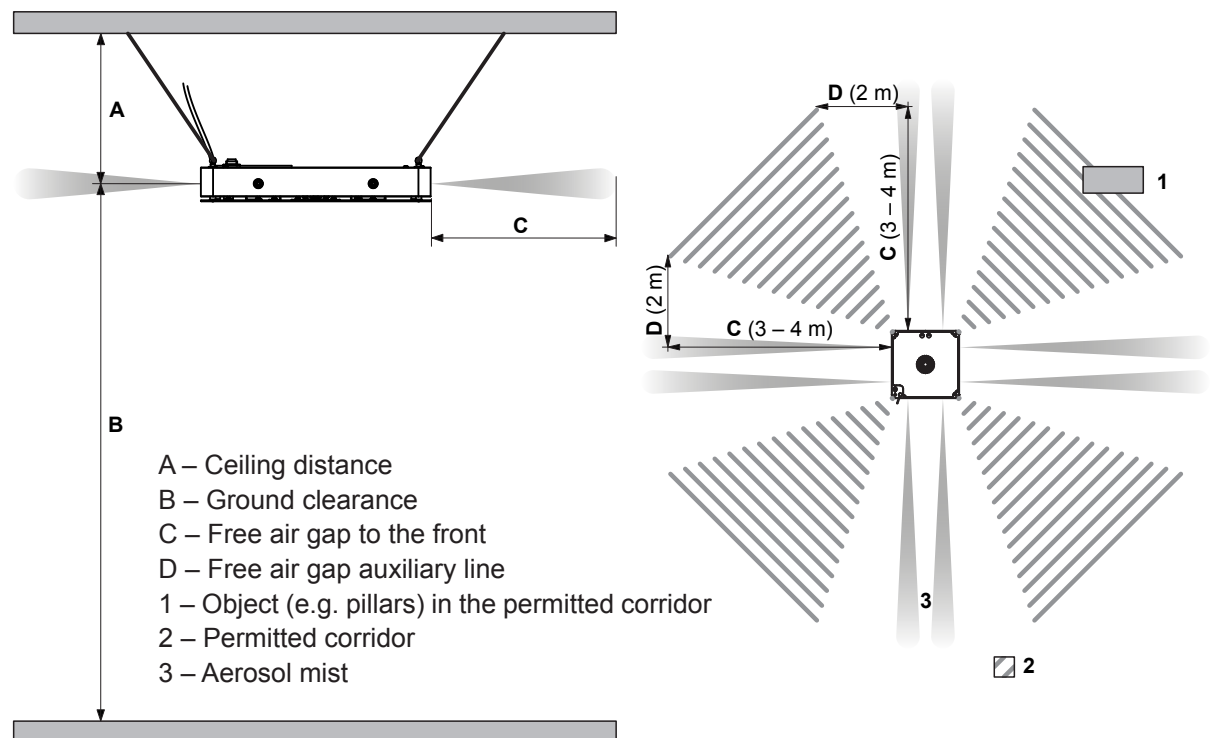

Fig. 18: Positioning the Condair Vita Stream nebulizer

Clearances Condair Vita Stream	
Ceiling clearance [A]	min. 1.0 m
Floor clearance [B]	min. 4.0 – 6.0 m
Free air gap [C]	min. 3.0 – 4.0 m
Free air gap [D]	min. 2.0 m

### 5.1.4.3 Mounting the Condair Vita Stream nebulizer

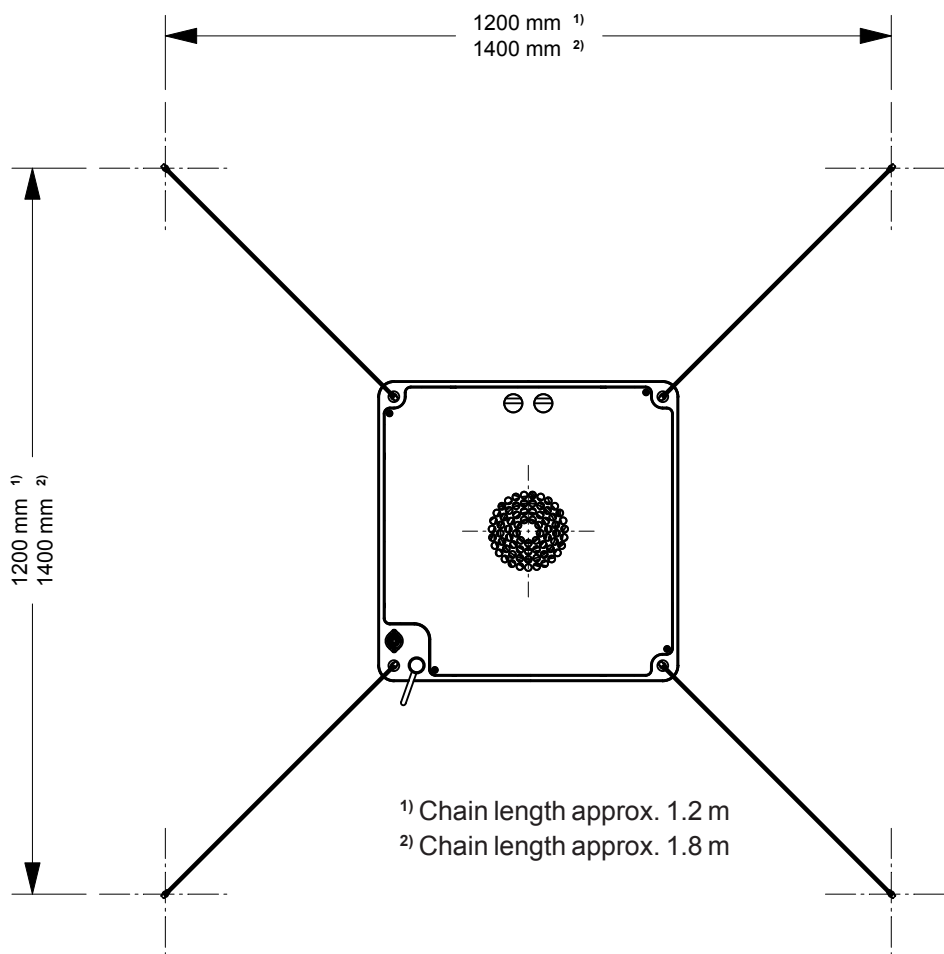

Fig. 19: Hole dimensions for chain suspension – Condair Vita Stream nebulizer

#### Mounting:

1. Mark the 4 points for attaching the chains at the desired location on the ceiling.
2. Drill appropriate holes and insert dowels.
3. Screw in the appropriate eyebolts.
4. Hook the 4 chains of the nebulizer into the eyebolts using snap hooks.

## 5.1.5 Positioning and mounting the Condair Vita Line nebulizer

### 5.1.5.1 Additional positioning instructions for the Condair Vita Line nebulizer

The positioning of a Condair Vita Line nebulizer is always determined during planning and noted in the system documents.

Prior to mounting the Condair Vita Line nebulizers, ensure that all hose layouts, distances between nebulizers and atomization clearances have been considered and adhered to, as per [Fig. 21](#).

The recommended hose layouts, distances between the Condair Vita Line nebulizers and atomization clearances, are shown below. Consult local and national installation regulations. Condair does not accept responsibility for violations of the installation codes.

The following general positioning notes, however, have to be read and complied with in any case:

- Make sure that the construction (rafter, beam, wall, pillar, ceiling construction, etc.) on which the devices and/or system components will be mounted disposes of a sufficient load-bearing capacity and is suitable for fixing
- Position the Condair Vita Line nebulizers in such a way to enable the atomized mist to spread freely. When the mist is prevented from spreading by obstacles (e.g. ceilings, beams, ventilation ducts, airflow, machinery, etc.), turbulences can build up and condensation may occur as a result.
- [Fig. 21](#) shows the recommended clearances, of the expansion of the atomization stream, and the clearances that have to be maintained. These are ideal and recommended distances under standard conditions using Condair nozzles. Different weather, climate and indoor conditions can alter the spread and distance of the mist.
- As shown in [Fig. 21](#), when the nozzles and humidification heads are placed one opposite the other, make sure that a minimum distance of 6 m is adhered to. This will avoid the streams to condensate each other.
- Pay attention to the airflow of the room. Do not install humidification heads or nozzles in the immediate vicinity of a supply, return or exhaust system or of a cold-air inlet.
- Do not direct Condair Vita Line nebulizers or their nozzles at cold parts of a building, e.g. outside walls, windows, etc. (risk of condensation).
- Insulate cold-water pipes in the area of the atomizing stream (risk of condensation).
- The evaporation process absorbs heat from the ambient air. For this reason, make sure that the atomized stream is not directed on persons or on places directly above workplaces.
- In order to guarantee optimum humidification, ensure that the nebulizers are sensibly distributed in the room.
- The system components must be mounted in such a way that there is enough space for operation and maintenance.

Please contact your Condair representative in case you have questions on positioning and clearances.

### 5.1.5.2 Positioning the Condair Vita Line nebulizers

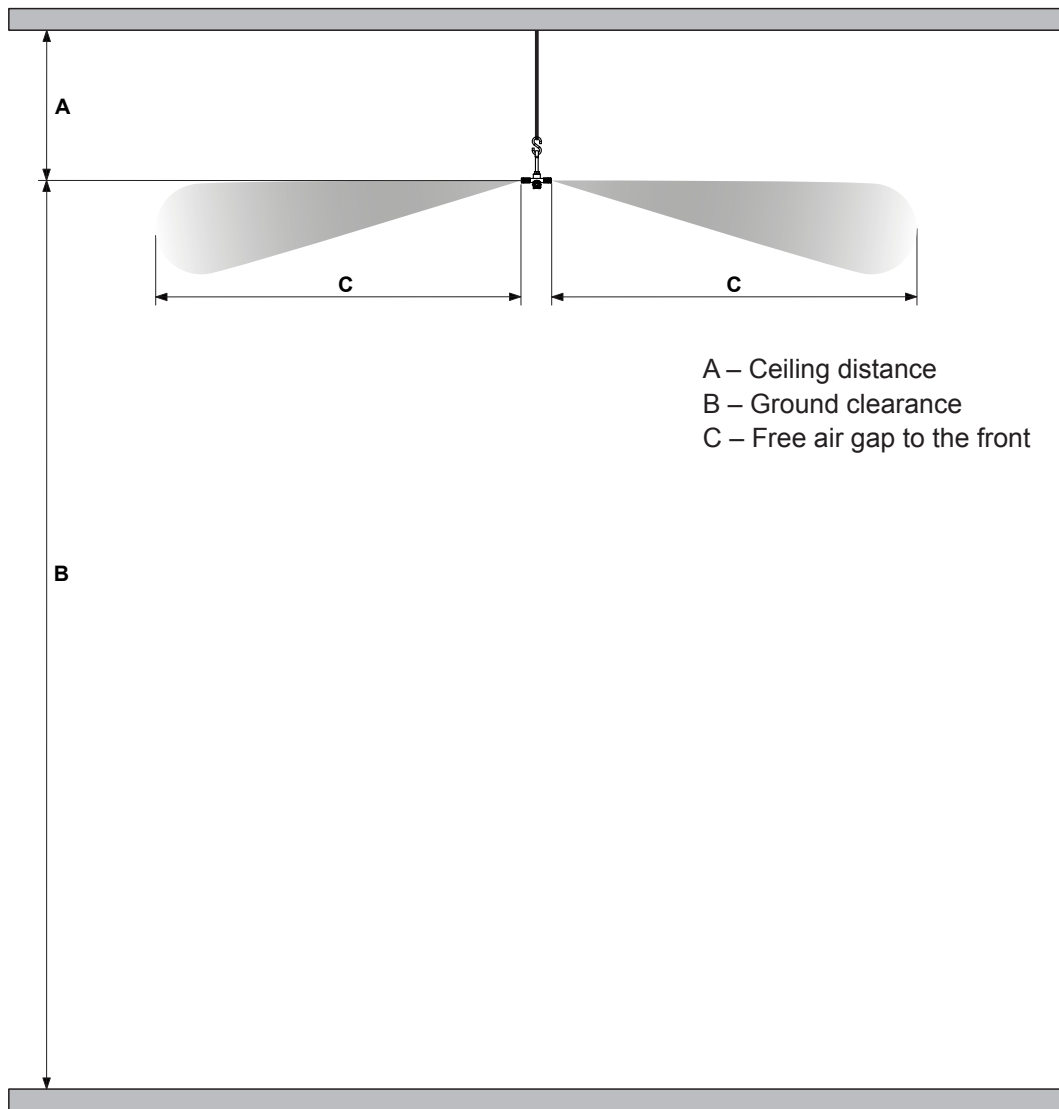

Fig. 20: Positioning the Condair Vita Line nebulizer

<b>Clearances Condair Vita Line</b>	
Ceiling clearance [A]	min. 0.2 – 1.0 m
Floor clearance [B]	4.0 – 6.0 m
Free air gap [C]	min. 3.0 m

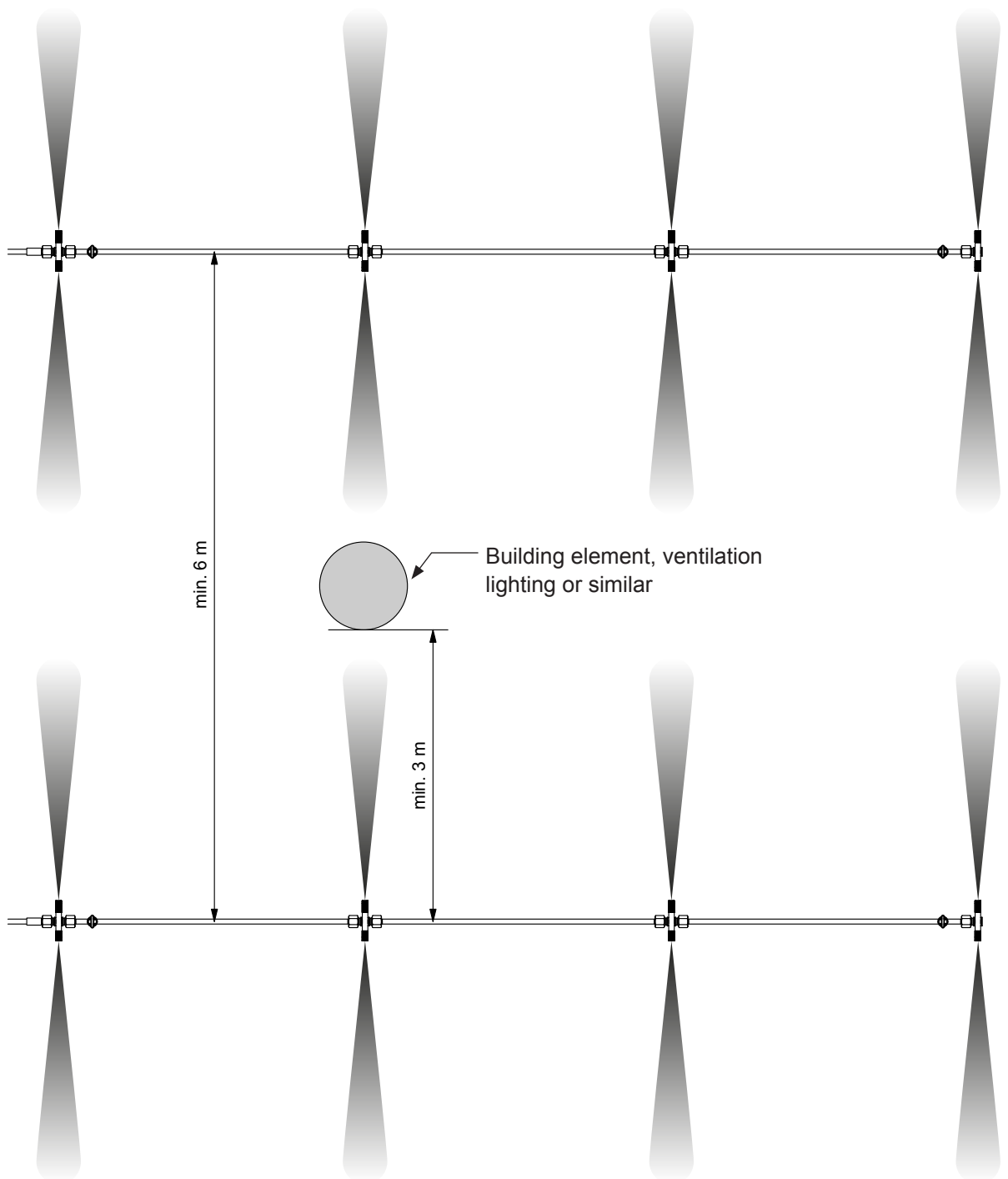
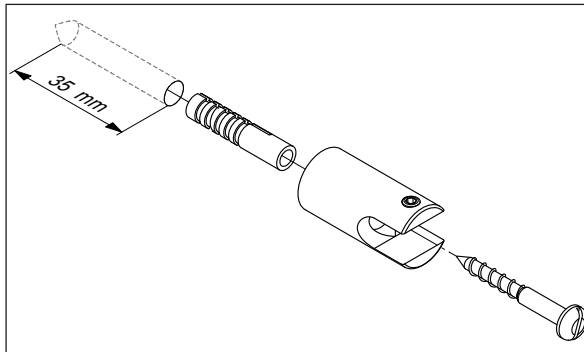

Fig. 21: Distances between the Condair Vita Line nebulizers

### 5.1.5.3 Assembly of the Condair Vita Line nebulizer

Condair Vita Line nebulizers are delivered from the factory as individual components and must be assembled on-site. Since the nebulizers can be several meters long, we recommend screwing together sections of 2 m to a maximum of 3 m, and then finally screwing these sections together when mounting them on the wall or ceiling.

Procedure:



Mount the wall mounts to the wall using 6 x 30 mm dowels and 4 x 35 mm screws or suitable wood or plaster screws (wood or plaster walls). Ensure that all wall mounts are mounted horizontally in a straight line.

The maximum distance between wall brackets is 1 m. Each Condair Vita Line nebulizer must be mounted with at least two wall brackets, even if the nebulizer is less than 1 m long.

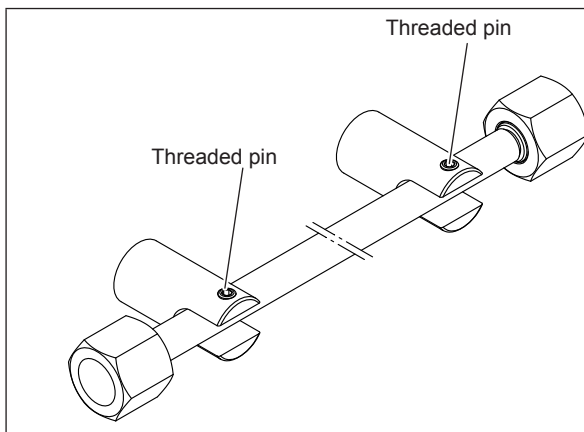

Insert the tubes into the hangers and secure them with the threaded pin (2 mm Allen key).

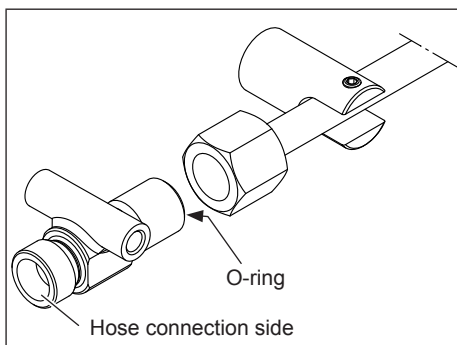

Install the hose connection T-piece. Ensure the O-ring is in place and that the nozzle mount is facing up.

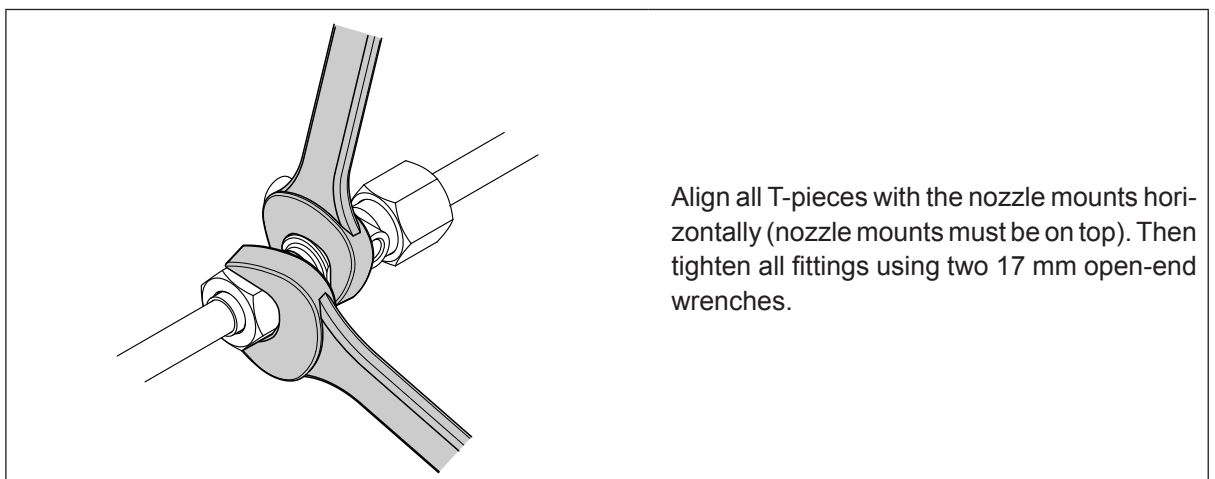
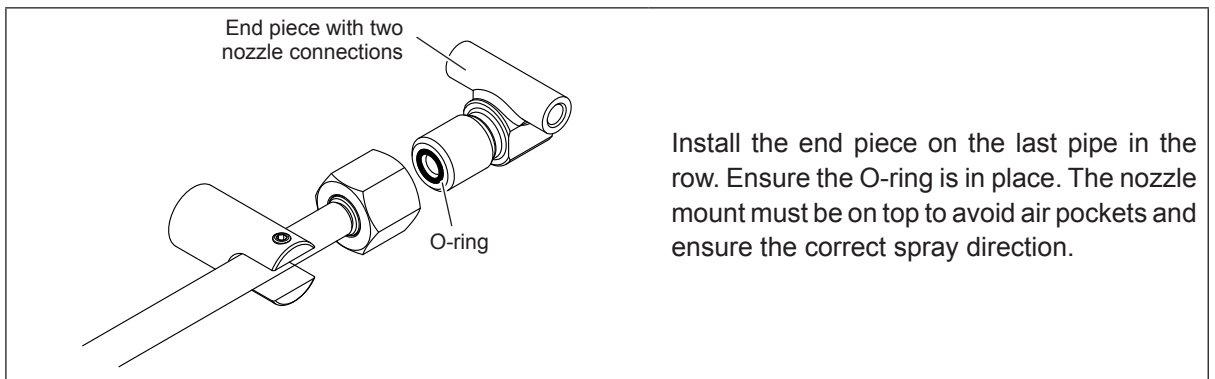
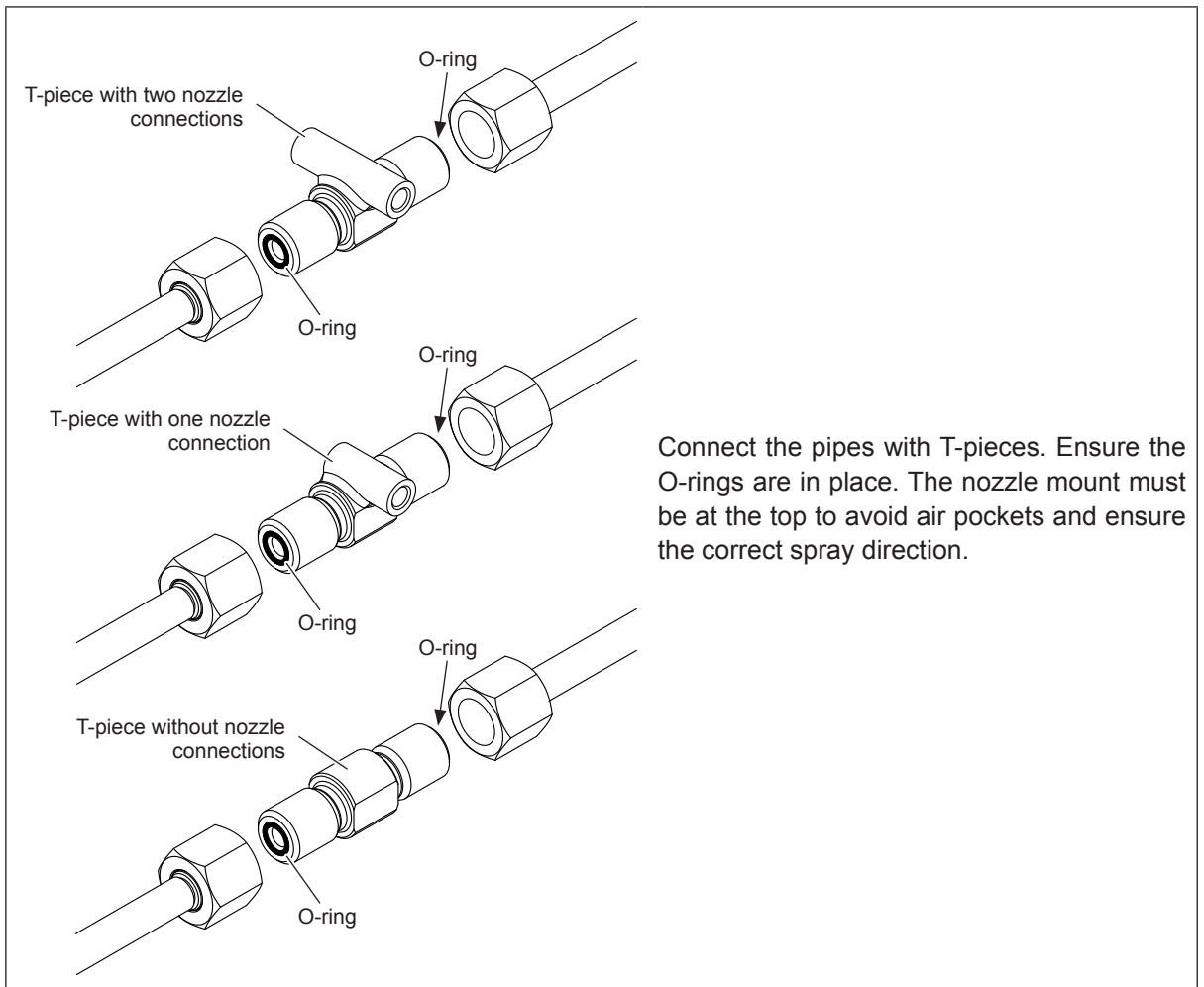

#### 5.1.5.4 Connecting the high-pressure hose

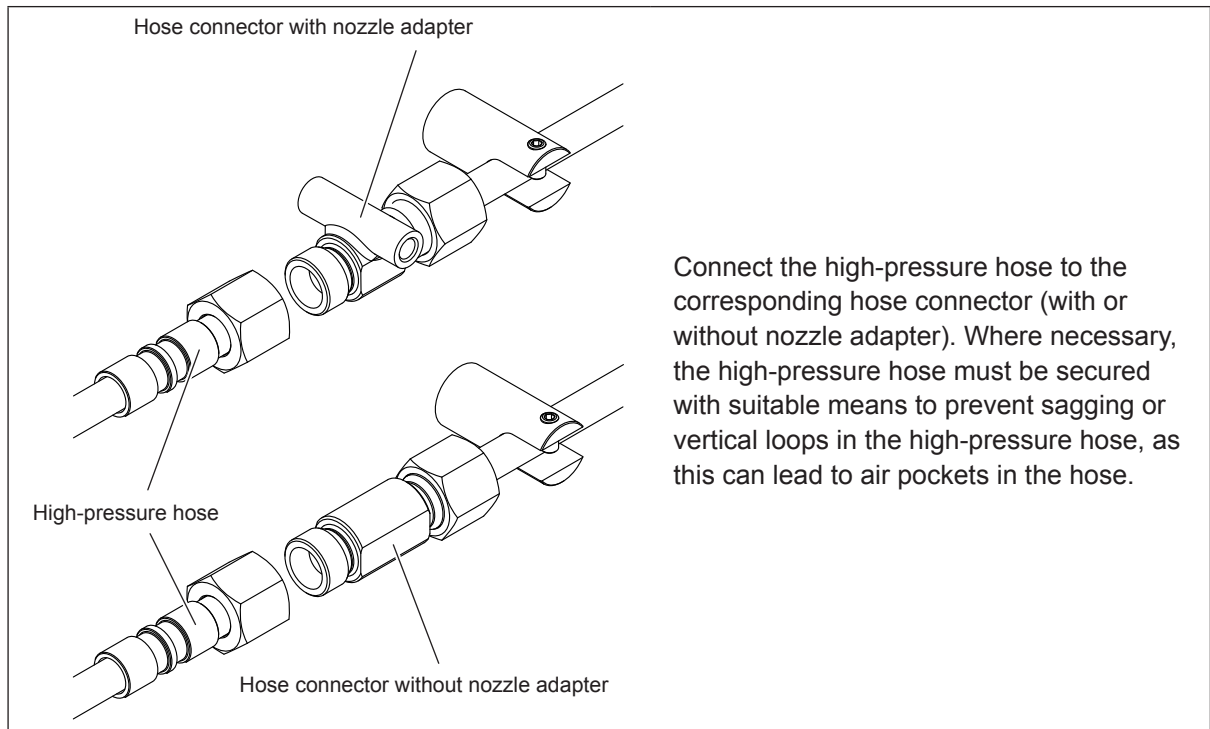

### 5.1.5.5 Inserting the nozzles

1. If connections or nozzle adapters have not been closed or have been left open for an extended period of time, thoroughly rinse the components of the Condair Vita Line with clean tap water before assembling the nozzles.
2. Before inserting the nozzle, check that its threads and O-ring are intact.
3. Screw the nozzles into the nozzle adapters of the Condair Vita Line nebulizer as shown in [Fig. 22](#) and tighten the nozzles by hand.  
**Important:** Nozzle openings that face to the wall must be closed with a blind nozzle (see [Fig. 22](#) right).
4. Use a set of polygrip pliers to tighten the nozzles (approx. 1/8 turn) (torque: 2.1 Nm  $\pm$ 0.1 Nm).
5. Ensure that the nozzle itself is tightened by tightening on the tip of the nozzle.

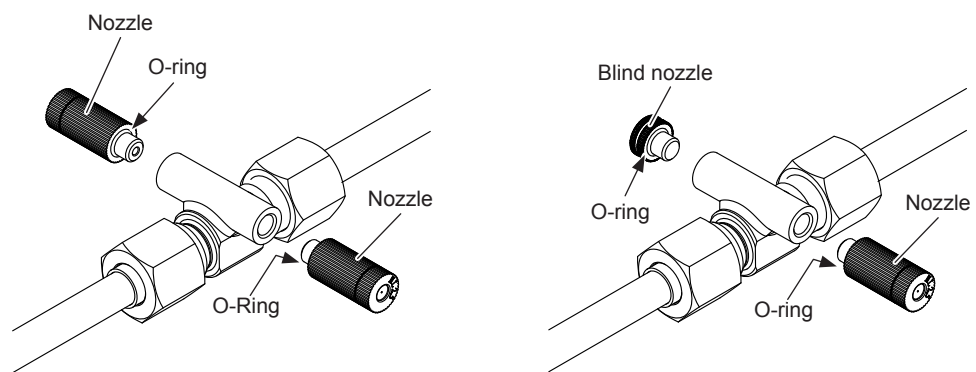

Fig. 22: Inserting the nozzles

### 5.1.5.6 Wall mounting of the Condair Vita Line nebulizer

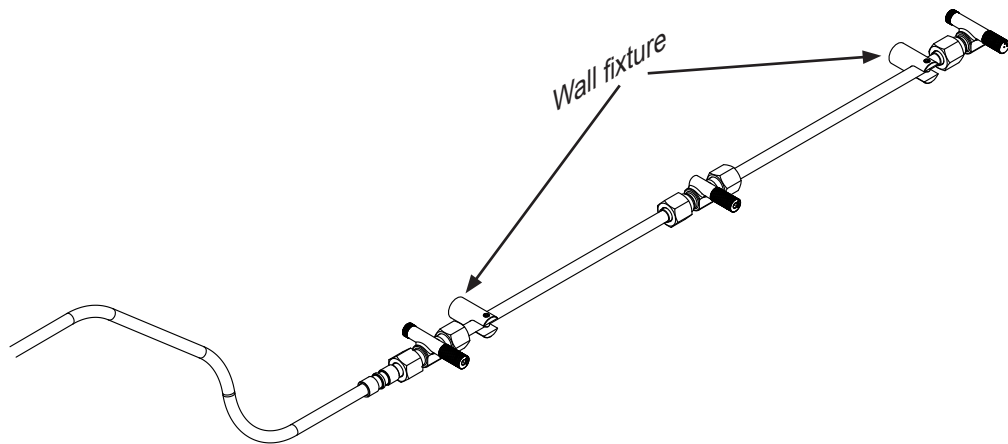

Fig. 23: Wall mounting of the Condair Vita Line nebulizer

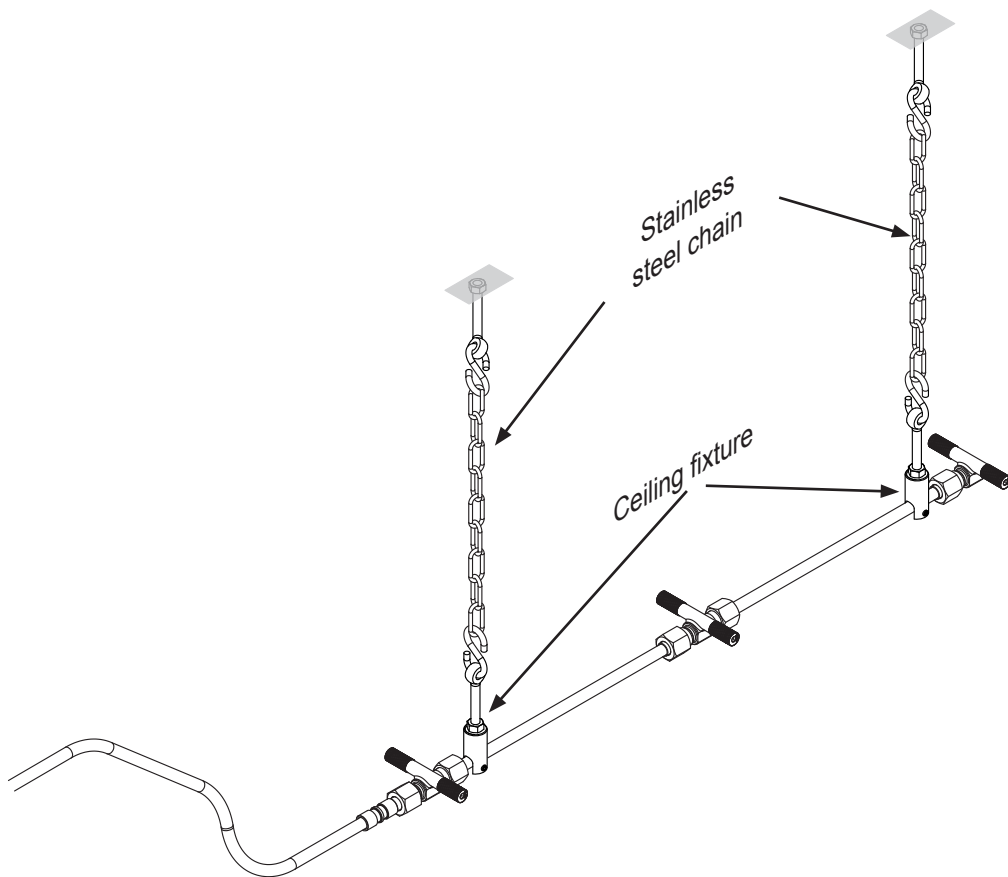

Fig. 24: Ceiling mounting of the Condair Vita Line nebulizer

## 5.1.6 Positioning and mounting the Condair Vita Space nebulizer

### 5.1.6.1 General notes on positioning

The positioning of a system is always determined during planning and noted in the system documents. Prior to mounting the Condair Vita Space nebulizers, ensure that all hose layouts, distances between nebulizers and atomization clearances have been considered and adhered to, as per [Fig. 25](#) and [Fig. 26](#).

The recommended hose layouts, distances between the Condair Vita Space nebulizers and atomization clearances, are shown below. Consult local and national installation regulations. Condair does not accept responsibility for violations of the installation codes.

The following general positioning notes, however, have to be read and complied with in any case:

- Make sure that the construction (rafter, beam, wall, pillar, ceiling construction, etc.) on which the devices and/or system components will be mounted disposes of a sufficient load-bearing capacity and is suitable for fixing.
- Position the Vita Space nebulizers in such a way to enable the atomized mist to spread freely. When the mist is prevented from spreading by obstacles (e.g. ceilings, beams, ventilation ducts, airflow, machinery, etc.), turbulences can build up and condensation may occur as a result.
- [Fig. 25](#) shows the recommended clearances, of the expansion of the atomization stream, and the clearances that have to be maintained. These are ideal and recommended distances at maximum capacities using Condair nozzles. Different weather, climate and indoor conditions can alter the spread and distance of the mist. As shown in [Fig. 26](#), when the nozzles and humidification heads are placed one opposite the other, make sure that a minimum distance of 8.0 m is adhered to. This will avoid the streams to condensate each other.
- Pay close attention to the airflow of the room. Do not install the nebulizers or nozzles in the immediate vicinity of a supply, return or exhaust system or of a cold-air inlet.
- Do not direct the nebulizers or their nozzles at cold parts of a building, e.g. outside walls, windows, etc. (risk of condensation).
- Insulate cold-water pipes in the area of the atomizing stream (risk of condensation).
- The evaporation process absorbs heat from the ambient air. For this reason, make sure that the nebulizer stream is not directed on persons or on places directly above workplaces.
- In order to guarantee optimum humidification, ensure that the nebulizers are sensibly distributed in the room.
- The system components have to be mounted in such a way to provide enough space for operation and maintenance.

Please contact Condair's Technical Service Team in case you have questions on positioning and clearances.

### 5.1.6.2 Positioning the Condair Vita Line nebulizers

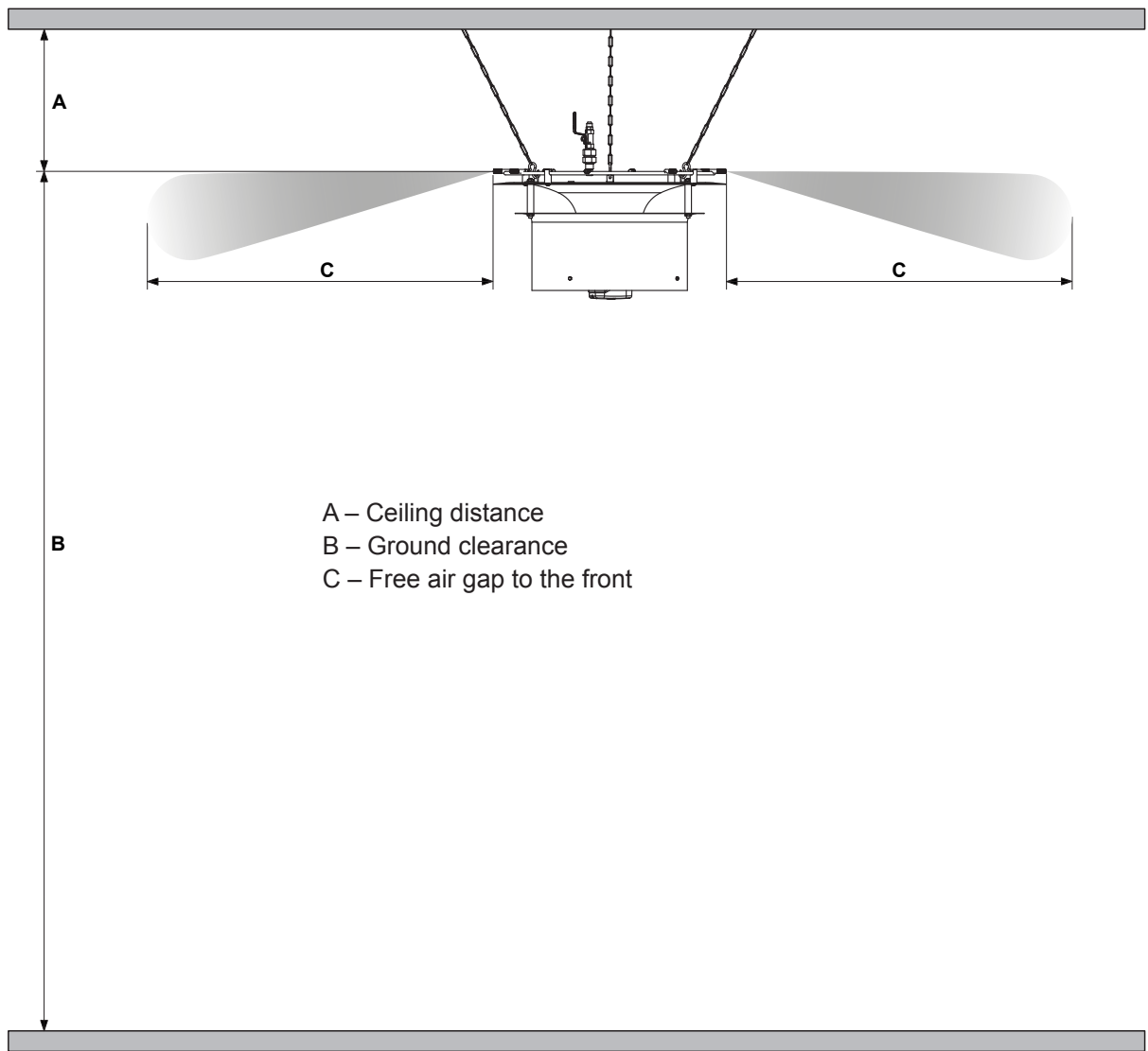
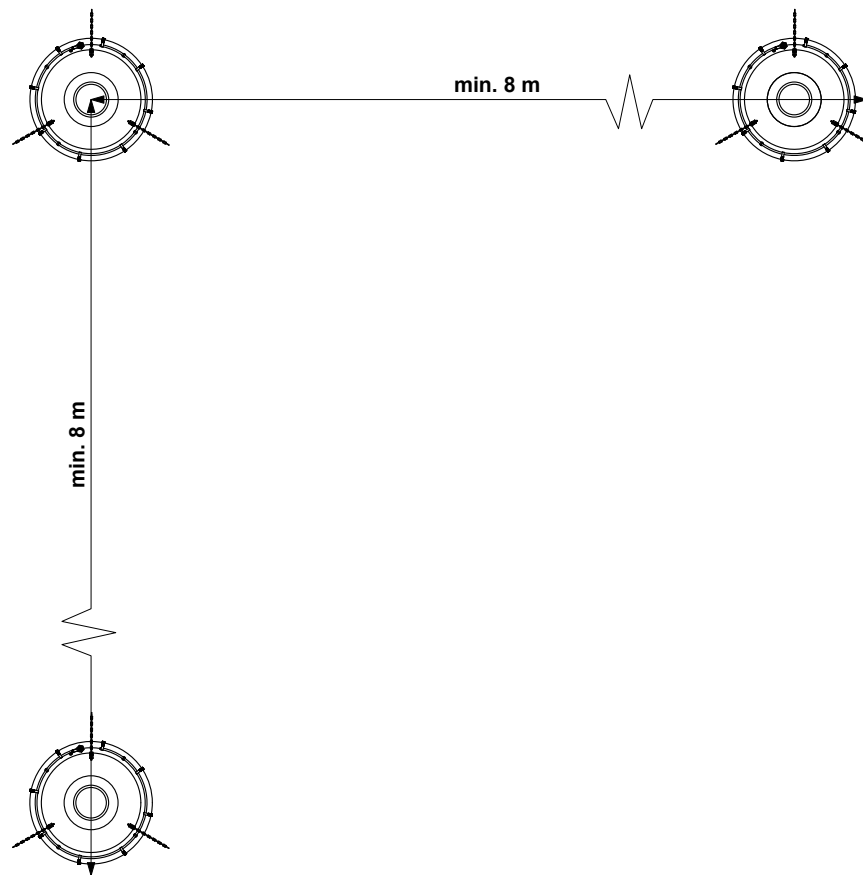

Fig. 25: Positioning the Condair Vita Space nebulizer

Minimum clearances Condair Vita Space	
Ceiling clearance [A]	0.5 m
Floor clearance [B]	4.0 – 6.0 m
Free air gap [C]	min. 3.0 m



*Fig. 26: Minimum distance between Condair Vita Space nebulizers*

### 5.1.6.3 Inserting the nozzle

6. If connections or nozzle adapters have not been closed or have been left open for an extended period of time, thoroughly rinse the components of the Condair Vita Space with clean tap water before assembling the nozzles.
7. Before inserting the nozzle, check that its threads and O-ring are intact.
8. Screw the nozzles into the nozzle adapters of the Condair Vita Space nebulizer as shown in [Fig. 27](#) and tighten the nozzles by hand.  
**Important:** Nozzle openings that face to the wall must be closed with a blind nozzle (see [Fig. 27](#)).
9. Use a set of polygrip pliers to tighten the nozzles (approx. 1/8 turn) (torque: 2.1 Nm  $\pm$ 0.1 Nm).
10. Ensure that the nozzle itself is tightened by tightening on the tip of the nozzle.

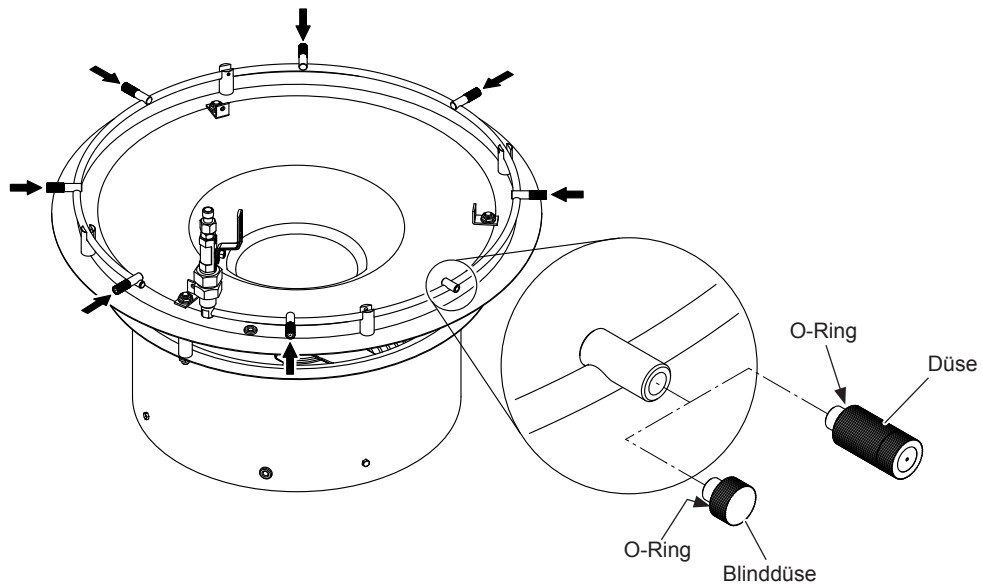

Fig. 27: Inserting the nozzles

#### 5.1.6.4 Mounting the Condair Vita Space nebulizers

Condair Vita Space nebulizers are typically suspended from the ceiling by chains, with water supplied via a high-pressure hose and electricity via a power supply cable. An optional wall bracket is available for wall mounting.

##### 5.1.6.4.1 Ceiling mounting

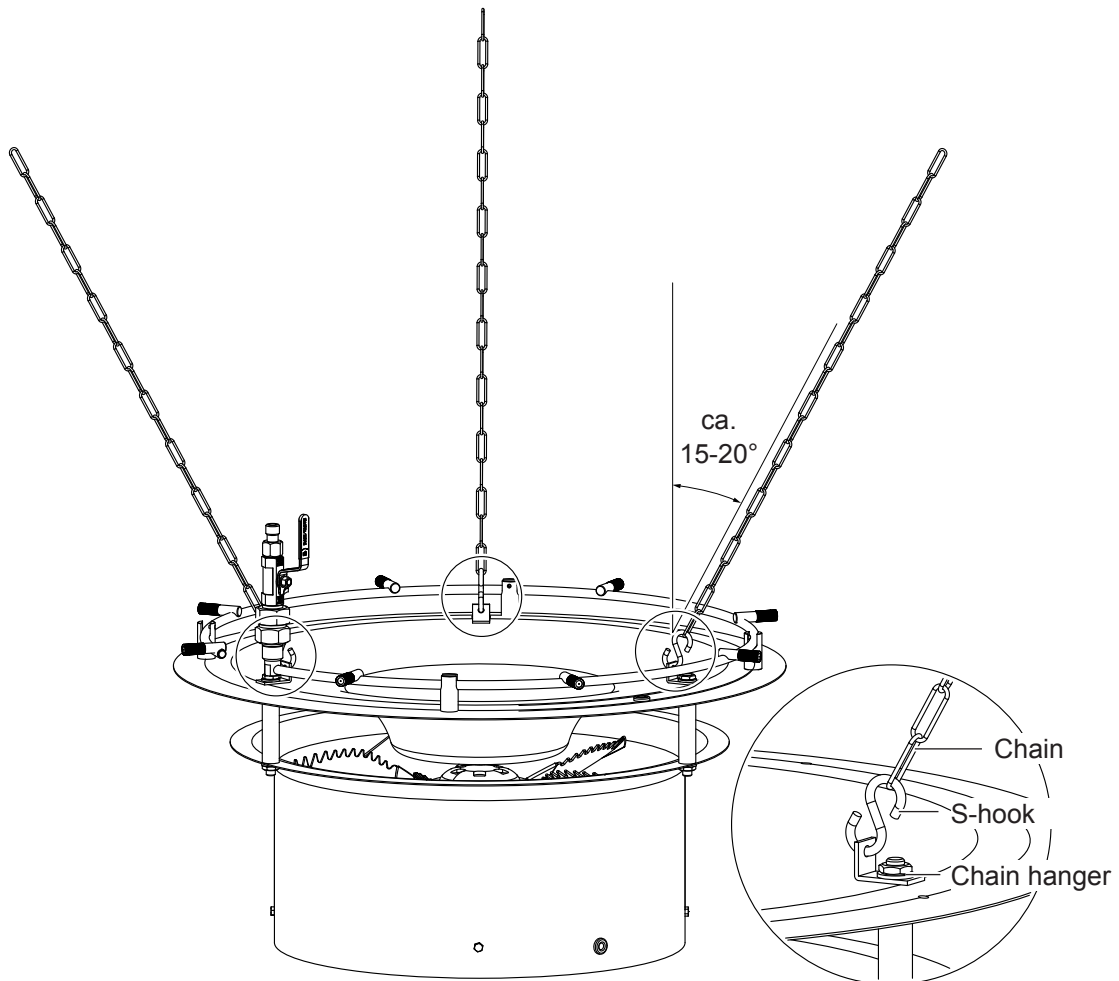

Fig. 28: Ceiling mounting Condair Vita Space

#### Mounting

1. Ensure that the structure (rafters, beams, ceiling, etc.) on which the nebulizer is to be mounted has a sufficient load-bearing capacity of at least four times the system weight and is suitable for fastening.
2. Using suitable materials (eye bolts, dowels, concrete anchors, etc.), create the fixings for the chains on the ceiling. Ensure that the chains from the Condair Vita Space can be routed to the ceiling fixings at an angle of approximately 15-20°.
3. Attach the chains to the chain hanger on the Condair Vita Space using the S-hooks.
4. Hang the chains of the Condair Vita Space in the ceiling fixings. Adjust the length of the chains so that the Condair Vita Space hangs horizontally.
5. When the Condair Vita Space is hanging horizontally, remove the excess chain and close the S-hooks.

### 5.1.6.4.2 Wall mounting

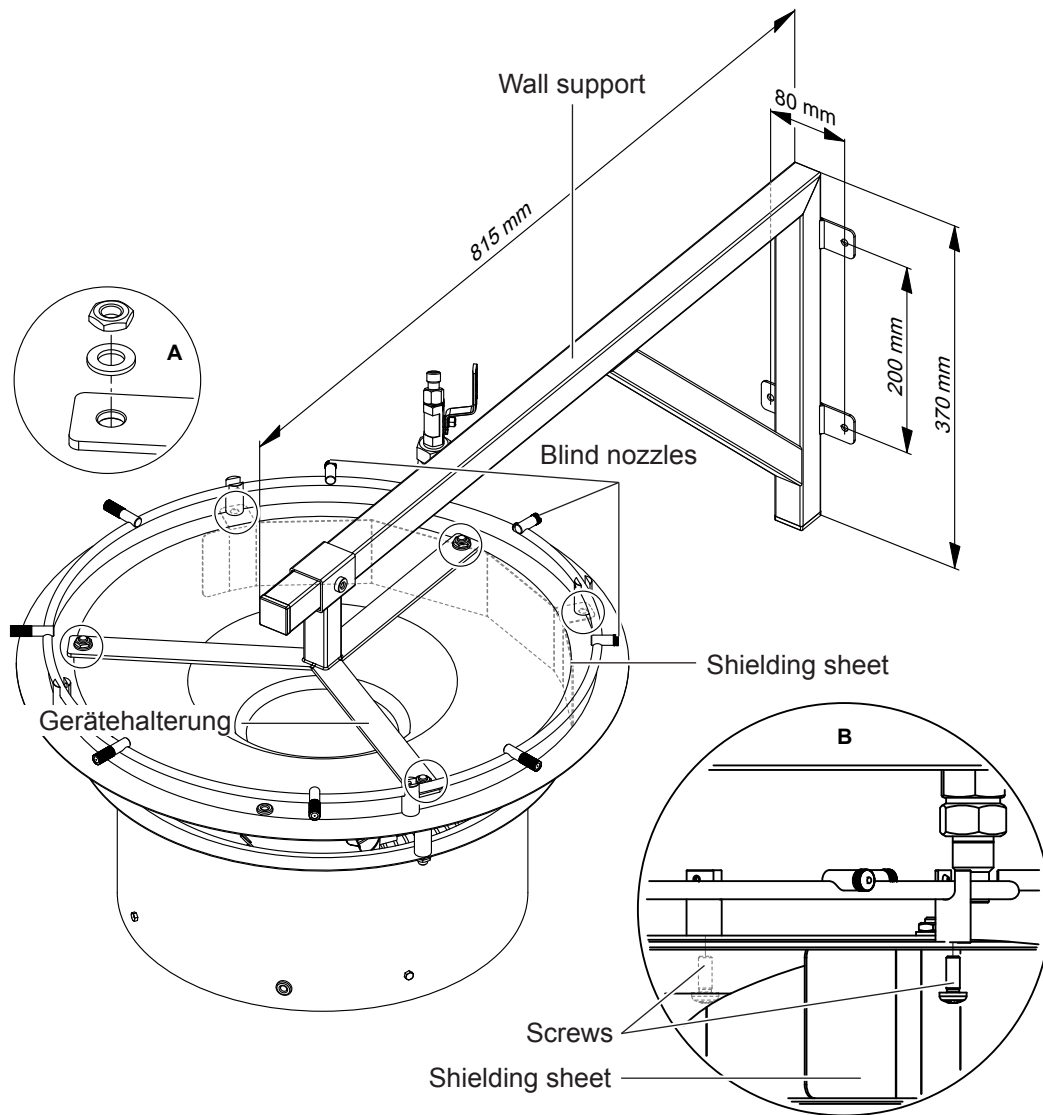

Fig. 29: Wall mounting Condair Vita Space

#### Technical specifications wall support

Article number	101102000
Material	Powder-coated steel
Color	Grey
Dimensions	815 x 370 x 100 mm
Weight	3.5 kg

## Mounting

1. Ensure that the wall on which the nebulizer is to be mounted has sufficient load-bearing capacity of at least four times the system weight and is suitable for mounting.
2. Mount the wall bracket to the wall using suitable mounting hardware (e.g., screws and wall plugs of the correct size).
3. Fix the supplied shielding sheet to the side facing the wall from below using the two screws to the baffle plate (see [Fig. 29, Detail A](#)).
4. Seal the nozzle openings facing the wall with the supplied blind nozzles.
5. Fix the three-pronged device holder to the baffle plate of the Condair Vita Space nebulizer using the nuts and washers (see [Fig. 29, Detail B](#)).
6. Slide the device holder with the Condair Vita Space nebulizer onto the arm of the wall support and adjust the distance to the wall (0.3 to approximately 0.55 m). Then secure the device holder to the arm of the wall support with the screw.

### 5.1.6.5 High pressure and power supply connection

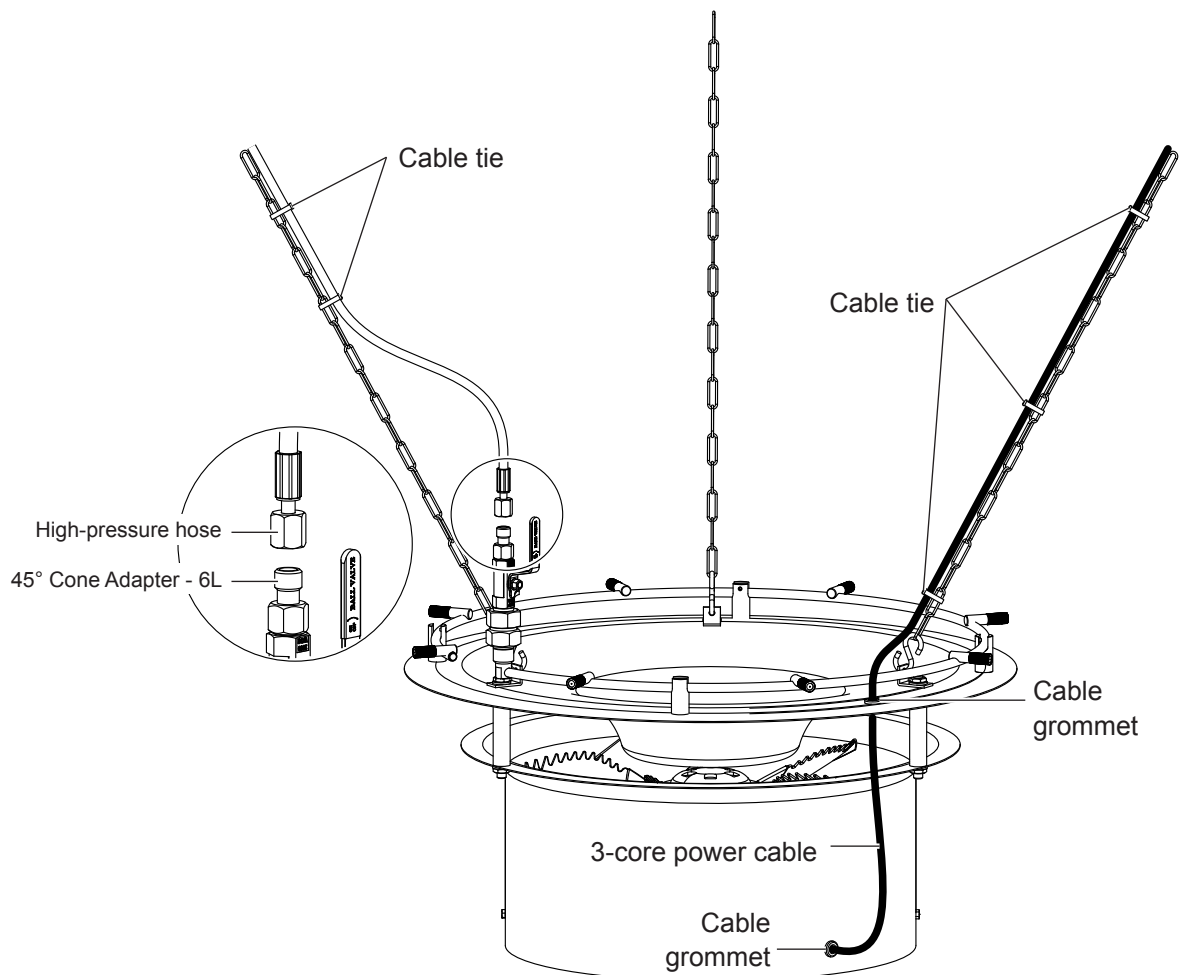

Fig. 30: Water and power supply connection

### High-pressure connection

- Route the high-pressure hose along one of the chains to the connection point and secure it to the chain with cable ties (see [Fig. 30](#)). When routing the high-pressure hose, ensure that there are no vertical loops in the hose. This can lead to air pockets in the hose and disrupt the operation later.  
Note: When wall-mounting the nebulizer, appropriate hose routing and fastening must be selected.
- After flushing the hose system, connect the high-pressure hose to the ball valve using the supplied adapter (see [Fig. 30](#)).

### Power supply connection

- Route the power supply cable along one of the chains to the nebulizer, then via the two cable grommets to the connection box at the bottom of the nebulizer. Secure the power supply cable to the chain with cable ties (see [Fig. 30](#)).  
Note: When wall-mounting the nebulizer, appropriate cable routing and fastening must be selected.

**DANGER!**  
**Danger of electric hazard!**

The following work steps may only be carried out by an authorized electrician who is familiar with the associated hazards.

- Feed the power supply cable through the cable gland into the nebulizer's connection box.
- Connect the power supply cable (3x0.75 mm<sup>2</sup>) to the terminals L1, N and PE in the connection box according to the wiring diagram (see [Fig. 30](#)).

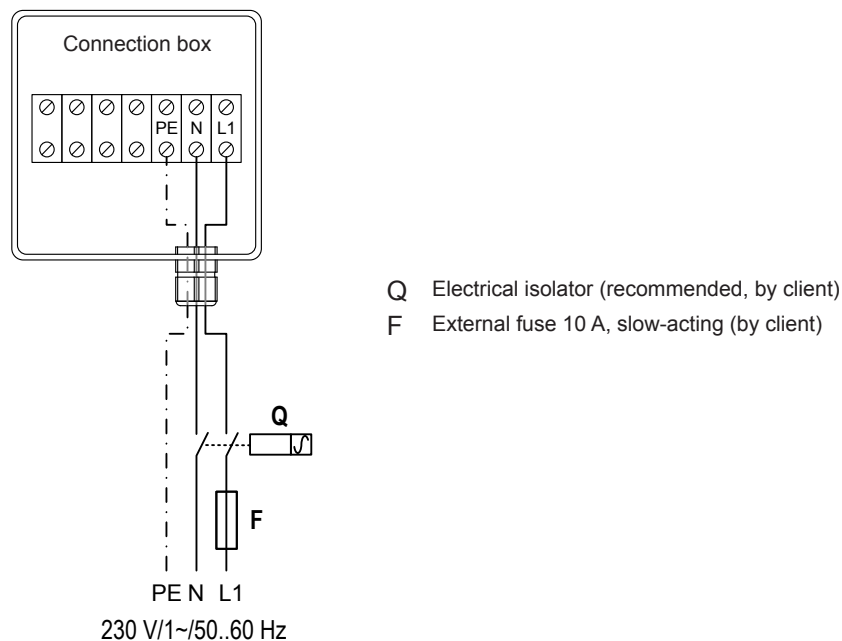

Fig. 31: Wiring diagram Condair Vita Space

## 5.2 Mounting the zones valves

### Notes on positioning the zone valves

The following notes on positioning must be strictly observed and followed:

- The zone valves must be placed as close as possible to the nebulizers of the respective zone..
- For the connection work, a free space of at least 60 cm must be available in front of the zone valves.

### Mounting the zone valves

The zone valves must be fixed to the wall at the designated location using the supplied mounting material. The notes on positioning the zone valves must be observed.

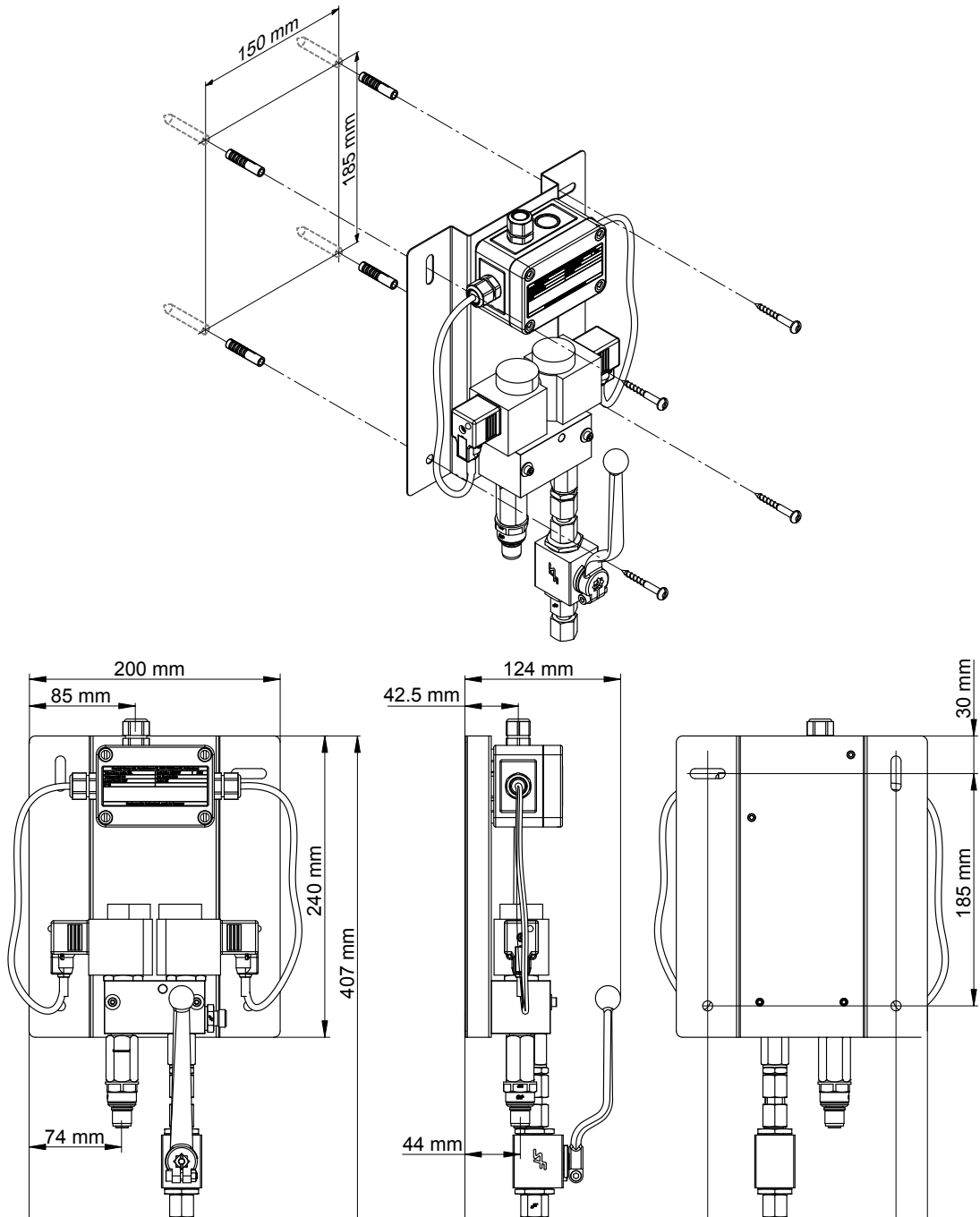

Fig. 32: Mounting the zone valve 75L

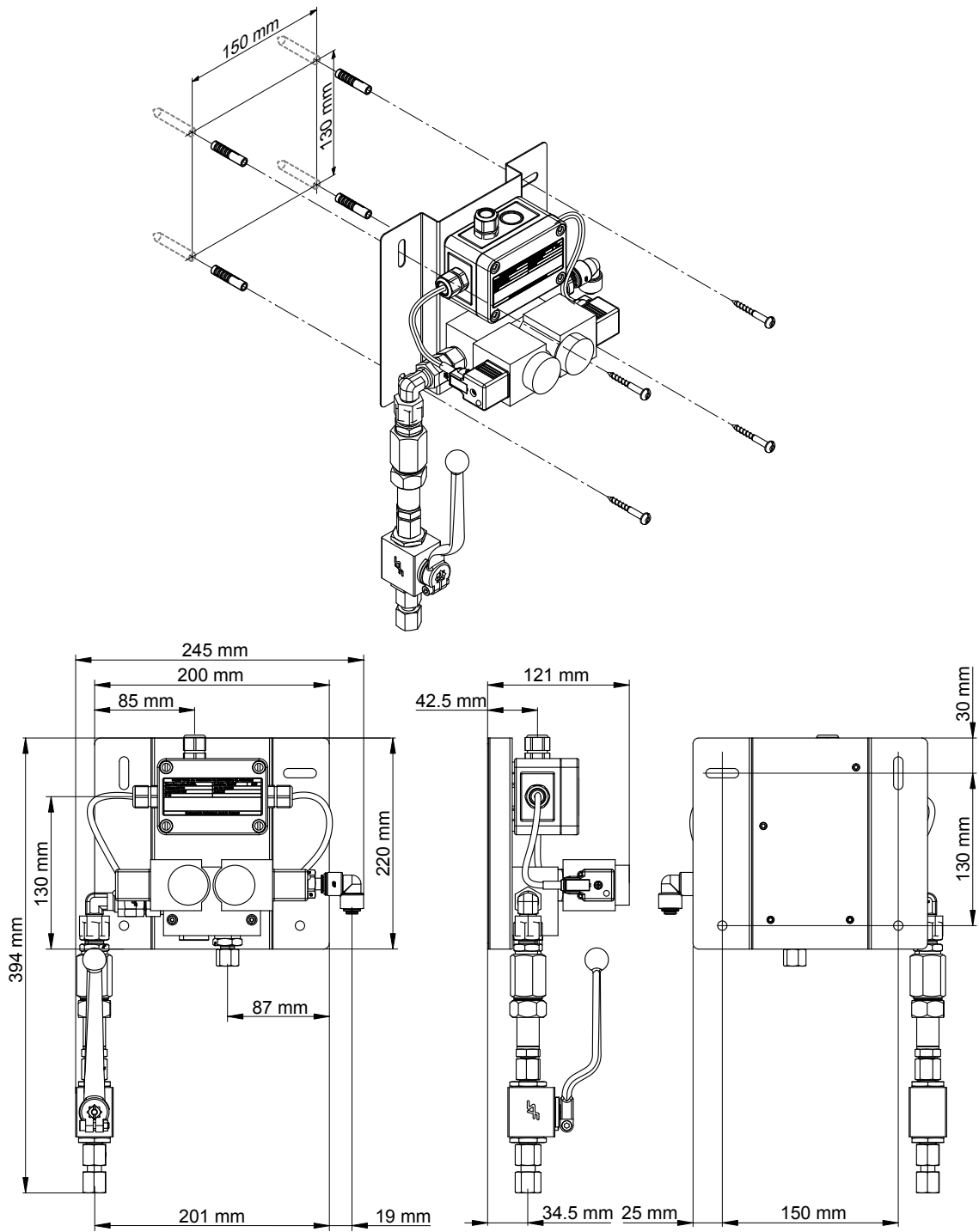

Fig. 33: Mounting the zone valve 60-360L

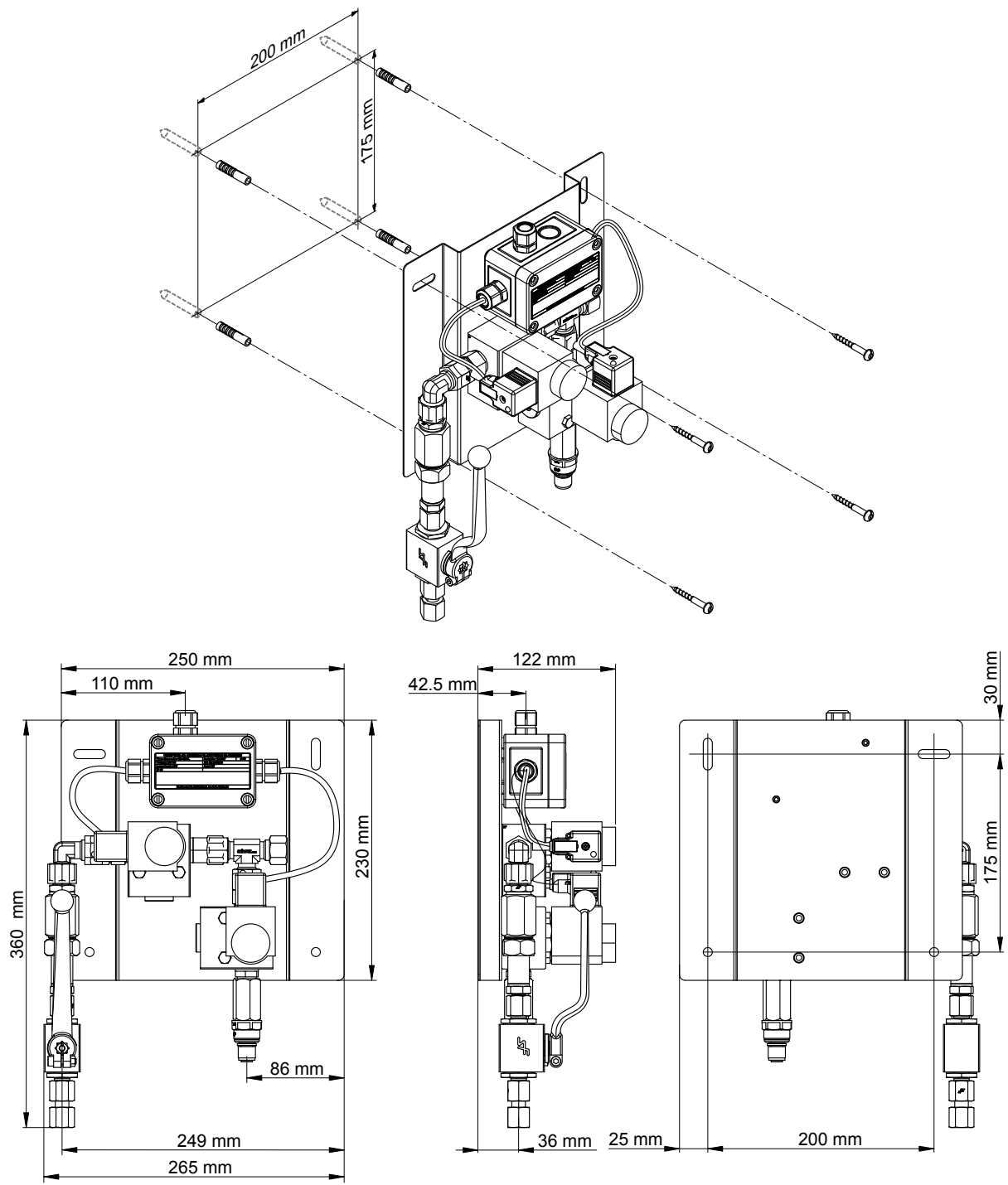

Fig. 34: Mounting the zone valve 120-1800L

### 5.3 Hydraulic connection of the nebulizers

The nebulizers are connected to the Condair Vita high-pressure water treatment system either via a high-pressure ring line system or a high-pressure string line system. Information on connecting the high-pressure ring line system or high-pressure string line system to the Condair Vita high-pressure water treatment system can be found in the installation instructions for the Condair Vita high-pressure water treatment system.

The high-pressure ring line or high-pressure string line systems are made using special high-pressure hoses (supplied). Depending on the design, the following high-pressure hoses are used:

- Ring line system: High-pressure hoses with  $\varnothing 1/4"$  and  $\varnothing 3/8"$
- String line system: High-pressure hoses with  $\varnothing 1/16"$ ,  $\varnothing 1/8"$ ,  $\varnothing 1/4"$  and  $\varnothing 3/8"$

Note: The ring line system can alternatively be made using stainless steel pipes  $\varnothing 10 \times 1$  mm with appropriate high-pressure fittings.

In both high-pressure systems, the individual nebulizers are supplied via short, standardized string lines ( $\varnothing 1/8"$ , max. 4 m) which are connected to the main line via a T-connector. The standardized string lines are equipped with a high-pressure coupling so that the nebulizers can be disconnected from the string or ring line under pressure.

#### 5.3.1 Dimensioning examples of high-pressure ring line with high pressure hoses

Min. pressure at nozzle	50 bar
Pump pressure	70 bar
Max. permissible pressure drop	20 bar

Ring line					
Hose size	Condair Vita water treatment system size	Min. flow	Max. flow	Max. loop length	Max. pressure drop
1/4"	100	35 l/hr	100 l/hr	800 m	10.9 bar
	300		300 l/hr	150 m	18.5 bar
	500		500 l/hr	50 m	17.1 bar
3/8"	100	80 l/hr	100 l/hr	800 m	1.5 bar
	300		300 l/hr	800 m	13.5 bar
	500		500 l/hr	400 m	18.8 bar

### 5.3.2 Dimensioning examples of high-pressure ring line with stainless steel pipe

Min. pressure at nozzle	50 bar
Pump pressure	70 bar
Max. permissible pressure drop	20 bar

Ring line					
Pipe size	Condair Vita water treatment system size	Min. flow	Max. flow	Max. loop length	Max. pressure drop
ø10x1 mm	100	60 l/hr	100 l/hr	800 m	6 bar
	300		300 l/hr	350 m	18 bar
	500		500 l/hr	150 m	18 bar

### 5.3.3 Dimensioning examples of high-pressure string line with high-pressure hose

Min. pressure at nozzle	50 bar
Pump pressure	70 bar
Max. permissible pressure drop	20 bar
Max. total string line length	425 m

String Line					
Hose size	Condair Vita water treatment system size	Min. flow	Max. flow	Max. string line length	Max. pressure drop
1/16"	100	1 l/hr	20 l/hr	25 m	6.2 bar
	300		20 l/hr		
	500		20 l/hr		
1/8"	100	10 l/hr	90 l/hr	50 m	15.0 bar
	300		90 l/hr		
	500		90 l/hr		
1/4"	100	35 l/hr	100 l/hr	150 m	2.1 bar
	300		200 l/hr		8.2 bar
	500		200 l/hr		8.2 bar
3/8"	100	80 l/hr	100 l/hr	200 m	0.5 bar
	300		300 l/hr		3.4 bar
	500		500 l/hr		9.4 bar

<b>Example string Line (max. length: 425 m and max. flow: 500 l/hr)</b>			
	<b>Max. flow</b>	<b>Max. lenght</b>	<b>Max. pressure drop</b>
Hose 1/16"	10 l/hr	25 m	2.1 bar
Hose 1/8"	35 l/hr	50 m	2.3 bar
Hose 1/4"	170 l/hr	150 m	5.9 bar
Hose 3/8"	500 l/hr	200 m	9.4 bar
Total Pressure drop			<b>19.7 bar</b>
Admissible pressure drop			<b>20 bar</b>
Total length		<b>425 m</b>	

<b>Example string Line (max. length: 425 m and max. flow: 300 l/hr)</b>			
	<b>Max. flow</b>	<b>Max. lenght</b>	<b>Max. pressure drop</b>
Hose 1/16"	10 l/hr	25 m	2.1 bar
Hose 1/8"	35 l/hr	50 m	2.3 bar
Hose 1/4"	170 l/hr	150 m	5.9 bar
Hose 3/8"	300 l/hr	200 m	3.4 bar
Total Pressure drop			<b>13.7 bar</b>
Admissible pressure drop			<b>20 bar</b>
Total length		<b>425 m</b>	

<b>Example string Line (max. length: 425 m and max. flow: 100 l/hr)</b>			
<b>Hose size</b>	<b>Max. flow</b>	<b>Max. lenght</b>	<b>Max. pressure drop</b>
Hose 1/16"	10 l/hr	25 m	2.1 bar
Hose 1/8"	35 l/hr	50 m	2.3 bar
Hose 1/4"	100 l/hr	350 m	4.8 bar
Hose 3/8"	-	-	-
Total Pressure drop			<b>9.2 bar</b>
Admissible pressure drop			<b>20 bar</b>
Total length		<b>425 m</b>	

### 5.3.4 General information

- Use only components that comply with the material specifications.
- The following minimum bend radius must be observed when routing the high-pressure hoses:
  - for 3/8" high-pressure hoses: R 70 mm
  - for 1/4" high-pressure hoses: R 55 mm
  - for 1/8" high-pressure hoses: R 40 mm
  - for 1/16" high-pressure hoses: R 30 mm
- The minimum bending radius to be observed for stainless steel tubes  $\varnothing 10 \times 1$  mm is: R 25 mm.
- For the production of the compression type fittings for the stainless steel pipes  $\varnothing 10 \times 1$  mm, please refer to the pipe manufacturer's instructions.
- The ends of the high-pressure lines (whether with or without a screwed-on fitting) must be sealed until final assembly to prevent dirt from entering the hoses/pipes.
- The union nuts of the high-pressure hoses must be tightened to the following torques:

Hose dimension	Torque
3/8"	70 Nm $\pm 2$ Nm
1/16", 1/8", 1/4"	42 Nm $\pm 2$ Nm

- The high-pressure lines must be fixed at regular intervals using appropriate brackets. The recommended distance between the brackets is 1 m.



**CAUTION!**  
**Damage to the hose due to incorrect installation**

When laying the hoses you must ensure that they do not rub on corners, wall feedthroughs, or wall openings, etc., to avoid damaging the high-pressure hoses. Please note that the hose may expand or contract due to differences in pressure and temperature.

### 5.3.5 Cutting the high-pressure hoses

Since Vita high-pressure hoses have a steel inner sheath for higher pressure resistance, we recommend the following special tools for cutting:

Hose dimension	Tool designation	Tool
1/16"	RS- PRO 541-6567	
1/8"		
1/4"	Wire rope cutter Felco C16	
3/8"		

### 5.3.6 Compressing the high-pressure hoses

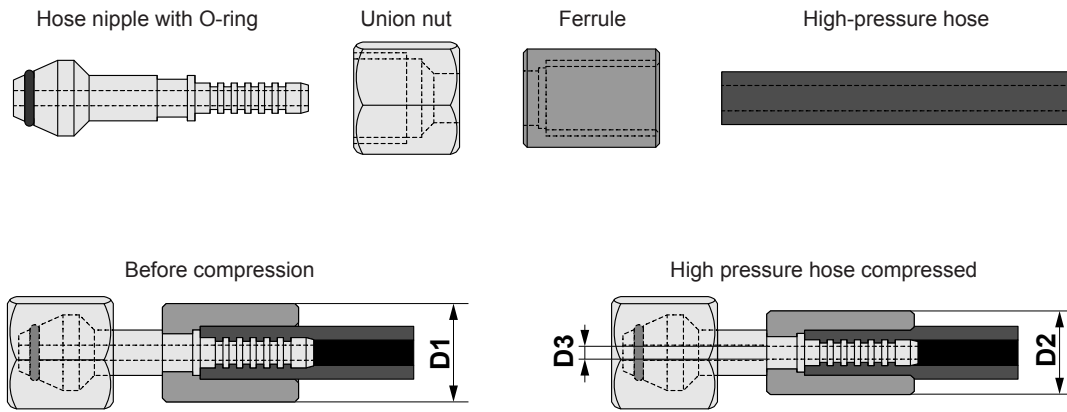

Fig. 35: Compressing the high-pressure hoses

#### Compression

For correct compression of the high-pressure hoses, please note the information on the hose compression device and the compression dimensions listed below.

#### Compression dimensions

Hose dimension	1/16"	1/8"	1/4"	3/8"
Inside	1.91	3.35	6.48	9.65
Outside	5.54	6.98	11.68	15.11
Fitting connection	M12x1.5	M12x1.5	M14x1.5	M18x1.5
Nominal diameter	2	4	6	10
Sealing cone screw connection with O-ring type	6L	6L	8L	12L
Article No. ferrule	2613485	2613486	2613487	2613488
Article No. hose nipple	2613490	2613491	2613492	2613493
Outer diameter of ferrule "D1" before compression	<b>8.8 mm</b>	<b>13.0 mm</b>	<b>20.0 mm</b>	<b>26.3 mm</b>
Outer diameter of ferrule "D2" after compression	<b>7.3 mm ±0.1 mm</b>	<b>10.5 mm ±0.1 mm</b>	<b>17.5 mm ±0.1 mm</b>	<b>19.6 mm ±0.1 mm</b>
Min. inner diameter of hose nipple "D3" after compression	<b>0.6 mm</b>	<b>1.5 mm</b>	<b>tbd</b>	<b>tbd</b>
Jaw size (Diameter range)	6 mm (6 - 8 mm)	10 mm (10 - 12 mm)	16 mm (16 - 18 mm)	18 mm (18 - 21 mm)
Compression tool mobile	Please contact your Condaire representative			

#### CAUTION!

- When compressing the fittings (ferrule and hose nipple), the specifications in the table above must be strictly followed.
- The compression dimensions "D2" and "D3" and correct compression must be checked for each fitting. Fittings that are incorrectly compressed must be replaced.

## 5.4 Positioning and mounting of the control components

### 5.4.1 Positioning and mounting the HumPower

#### Notes on positioning the HumPower

- Place the HumPower at a suitable height for operation (recommended: 1.2 - 1.6 m from the ground).
- For the connection work, a clearance of at least 60 cm must be available in front of the HumPower.
- Position the HumPower so that the electrical connection cables can be fed into the device from below through the cable glands.
- The HumPower must be positioned so that the maximum cable length of 500 m to the safety humidistat or nebulizer in the zone is not exceeded.

#### Mounting the HumPower

The HumPower should be fixed to the wall at the designated location using the supplied mounting material, taking into account the positioning instructions.

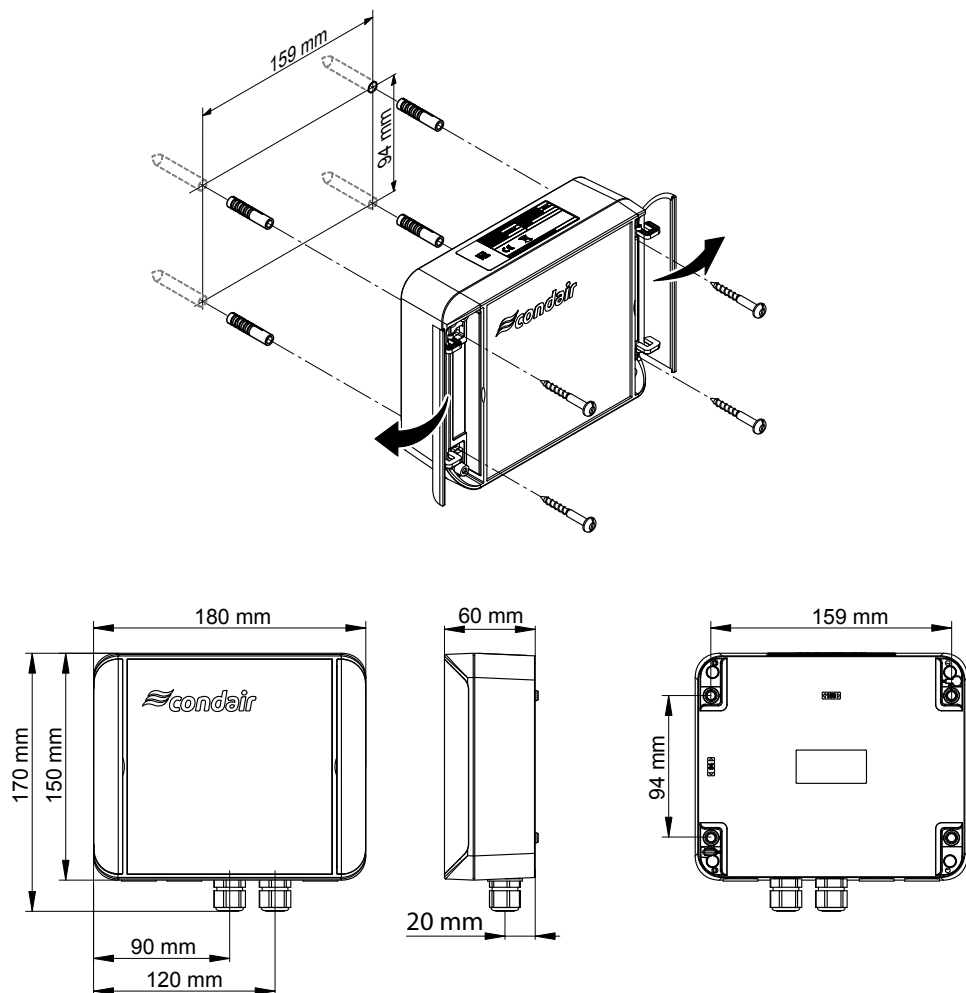

Fig. 36: Mounting the HumPower

## 5.4.2 Positioning and mounting the HumPower 24V

### Notes on positioning the HumPower 24V

- Place the HumPower 24V at a suitable height for operation (recommended: 1.2 - 1.6 m from the ground).
- For the connection work, a clearance of at least 60 cm must be available in front of the HumPower 24V.
- Position the HumPower 24V so that the electrical connection cables can be fed into the device from below through the cable glands.
- The HumPower 24V must be positioned so that the maximum cable length of 500 m to the safety humidistat or nebulizer in the zone is not exceeded.

### Mounting the HumPower

The HumPower 24V should be fixed to the wall at the designated location using the supplied mounting material, taking into account the positioning instructions.

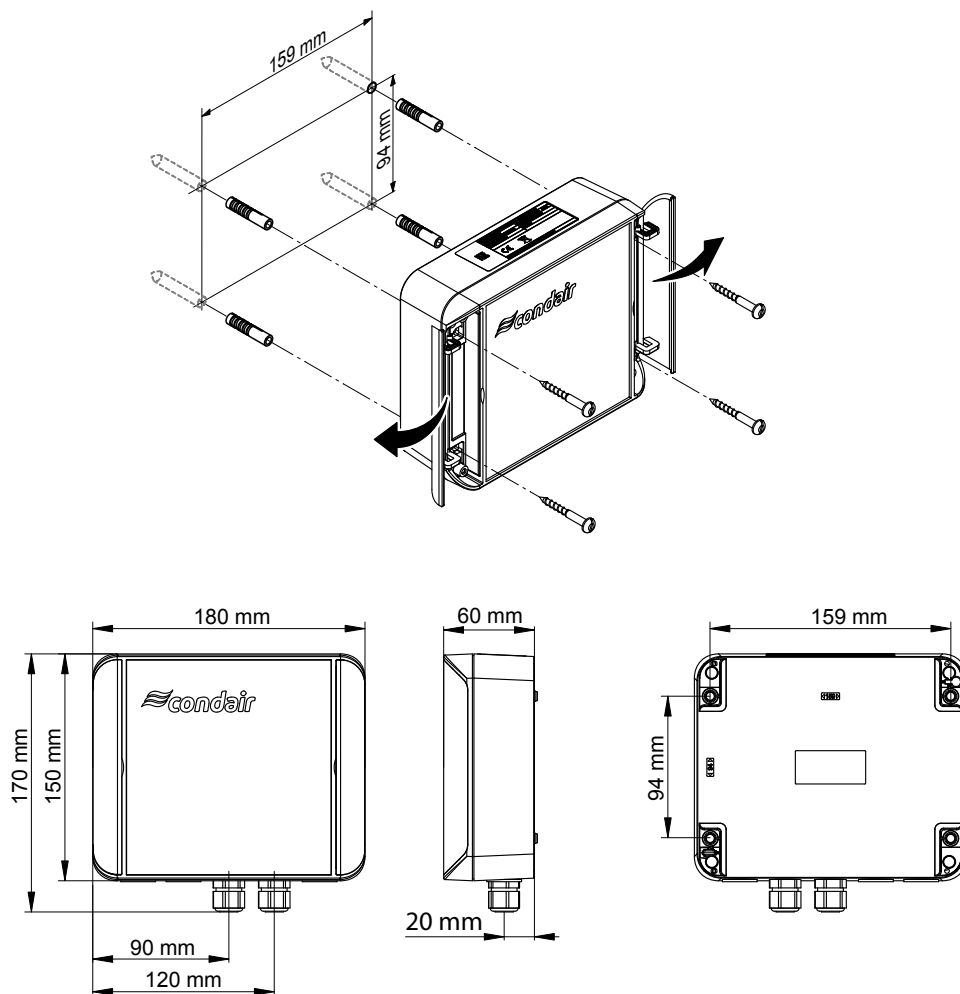

Fig. 37: Mounting the HumPower 24V

### 5.4.3 Positioning and mounting the CAN-Bus Extender

#### Notes on positioning the CAN-Bus Extender

- Place the CAN-Bus Extender at a suitable height for operation (recommended: 1.2 - 1.6 m from the ground).
- For the connection work, a clearance of at least 60 cm must be available in front of the CAN-Bus Extender.
- Position the CAN-Bus Extender so that the electrical connection cables can be fed into the device from below through the cable glands.
- The HumPower 24V must be positioned so that the maximum cable length of 500 m to the safety humidistat or nebulizer in the zone is not exceeded.

#### Mounting the CAN-Bus Extender

The CAN bus extender should be fixed to the wall at the designated location using the supplied mounting material, taking into account the positioning instructions.

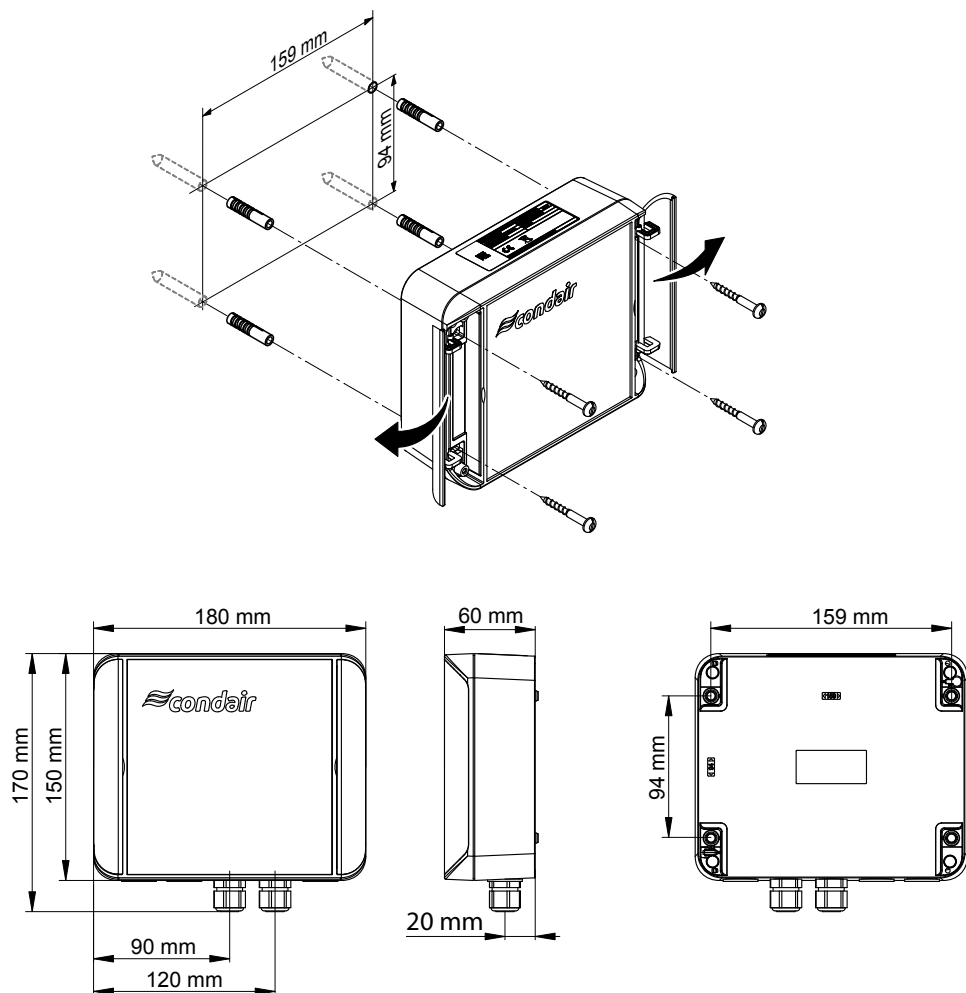

Fig. 38: Mounting the CAN-Bus Extender

## 5.4.4 Positioning and mounting the junction boxes

### Notes on positioning the junction boxes

- Position the junction boxes so that the electrical connection cables can be as short as possible.
- For the connection work, a clearance of at least 60 cm must be available in front of the junction boxes.

### Mounting the junction boxes

The junction boxes must be fixed to the wall at the designated location using suitable mounting material (not included), taking into account the placement instructions.

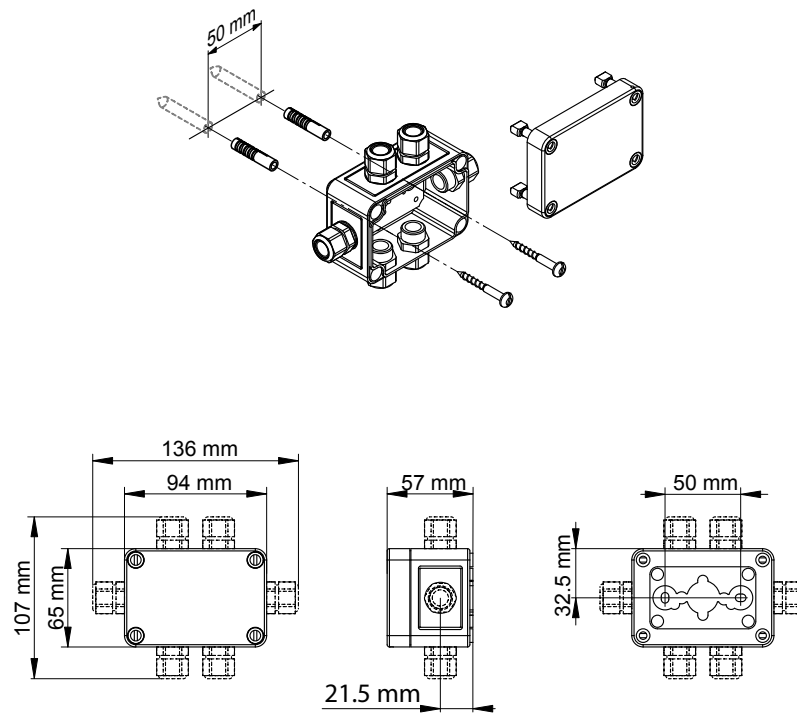

Fig. 39: Mounting the junction box

## 5.4.5 Positioning and mounting the industrial sensor gateways

### Notes on positioning the industrial sensor gateways

- Place the industrial sensor gateway at a suitable height for operation (recommended: 1.2 - 1.6 m from the ground).
- For the connection work, a clearance of at least 60 cm must be available in front of the industrial sensor gateway.
- Position the industrial sensor gateway so that:
  - the electrical connection cables can be fed into the device from below via the cable glands..
  - the maximum CAN bus cable length of 200 m to the Condair Vita System Master and to the downstream CAN bus devices is not exceeded..
  - the maximum cable length to the industrial humidity sensor of 400 m is not exceeded..

### Mounting the industrial sensor gateway

The industrial sensor gateway should be fixed to the wall at the designated location using the supplied mounting material, taking into account the positioning instructions.

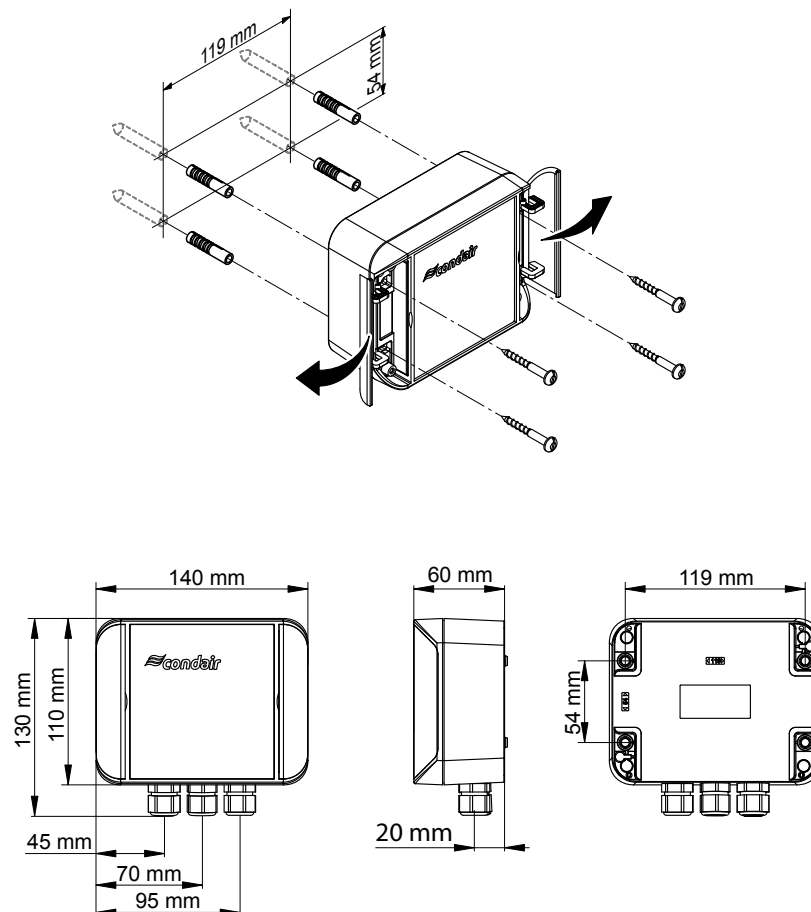

Fig. 40: Mounting the industrial sensor gateway

## 5.4.6 Positioning and mounting the industrial humidity sensor

### Notes on positioning the industrial humidity sensor

- Place the industrial humidity sensor in the room so that:
  - it is not exposed to direct sunlight.
  - it is not located in niches or behind covers.
  - it is not located above heat sources (such as radiators, fan heaters, etc.).
  - it is not exposed to air currents.
  - the maximum cable length to the industrial sensor gateway of 40 m is not exceeded..

### Mounting the humidity

The industrial humidity sensor should be mounted on the wall at the designated location using the supplied bracket, following the placement instructions. The orientation of the industrial humidity sensor (vertical or horizontal) is irrelevant.

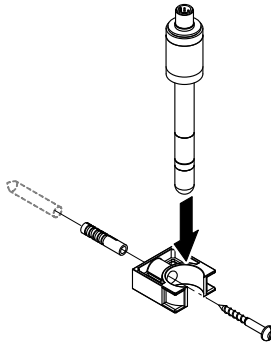

*Fig. 41: Mounting the Industrial Sensor*

## 5.4.7 Positioning and mounting the HumSpot

For positioning and mounting the HumSpot, please refer to the instructions in the separate HumSpot manual.

## 5.4.8 Positioning and mounting the safety humidistat

For positioning and mounting the safety humidistats, please refer to the instructions in the separate safety humidistat manual.

## 5.5 Electrical connection of the nebulizers

### 5.5.1 General connection instructions

The documentation does not cover installation of the mains power. However, it does contain requirements for the latter. The installation of the electrical components of the Condair nebulizers is described, as is the location for installing the mains power.

Notes on electrical installation:

- The connected nebulizers must be suitable for the voltage ranges of the fixed connection (115V OR 230V) (observe the type plate specifications).
- In the case of screw connections, the flexible cable ends must be provided with suitable ferrules.
- When connecting the lines with cable splice connectors (e.g. Wago 221-615), the ferrules can be omitted.
- The specified values for safeguarding must be observed and complied with.
- The maximum permissible output of the power supply devices (HumPower and HumPower 24 V) must not be exceeded when several nebulizers are connected.
- The system must be installed exclusively in accordance with the diagrams discussed in this document.
- Switch off the power supply during installation and secure the system against being switched on accidentally.
- The devices comply with protection class IP20 at a minimum. The ambient conditions must be suitable for this protection class.



**DANGER!**  
**Risk of electrocution**

Some of the Condair nebulizers work with mains voltage (115-230V AC, 50-60Hz).

For this reason: Before starting work on the electrical connections, make sure that the Condair Vita high pressure water treatment system and the HumPower units are disconnected from the power supply and secured against accidental switching on.



**DANGER!**  
**GFCI protection**

Water-carrying lines are installed in the devices themselves. Therefore, it can never be ruled out that water could come into contact with electrical parts. For this reason, the power supply must be provided via a residual current circuit breaker (GFCI switch).

## 5.5.2 HumPower connections

Each Area must be equipped with a HumPower connected to a 110-230V, 50-60Hz mains supply socket (see also [Fig. 8](#) to [Fig. 11](#)).

Each HumPower has the following connectors (see [Fig. 42](#)):

Terminal block	Description
X1 (POWER)	Terminal block (L/N/PE) for connecting the mains supply cable.
X2 (VALVE OUT)	Terminal block (L/N/PE) for connecting 115-230V, 50-60Hz consumer(s) via junction box(es) or directly. Note: The protective earth connector on the most left is used to connect the shielding of the CAN bus Out cable.
X3 (FAN)	Terminal block (24V/GND) for connecting one or more Condaire Vita Sky S/M1/M2 nebulizers of an area via junction box(es) or directly (one nebulizer only). For the maximum number of nebulizers that can be connected, see <a href="#">Section 4.3.2</a> .
X4 (MAX.HYG)	Terminal block (OUT/IN) for connecting the safety humidistat of the area.
X5 (BUS IN)	Socket to connect the HumPower to the previous CAN bus device.
X6 (BUS OUT)	Socket to connect the HumPower to the following CAN bus device. Note: If the HumPower is the last device in the CAN bus net the bus termination board must be connected to this connector.
X8 (SHIELD OUT)	Terminal block for connecting the shielding of the CAN bus IN cable.

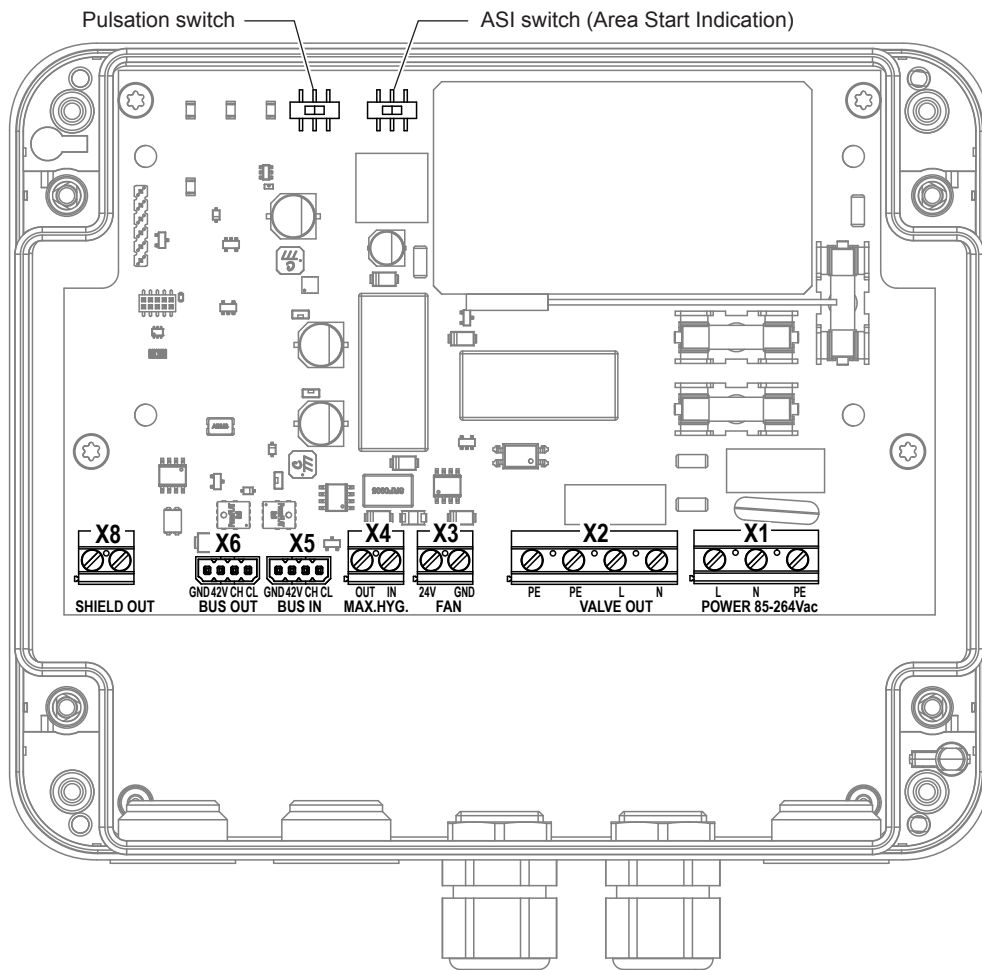

Fig. 42: HumPower connections

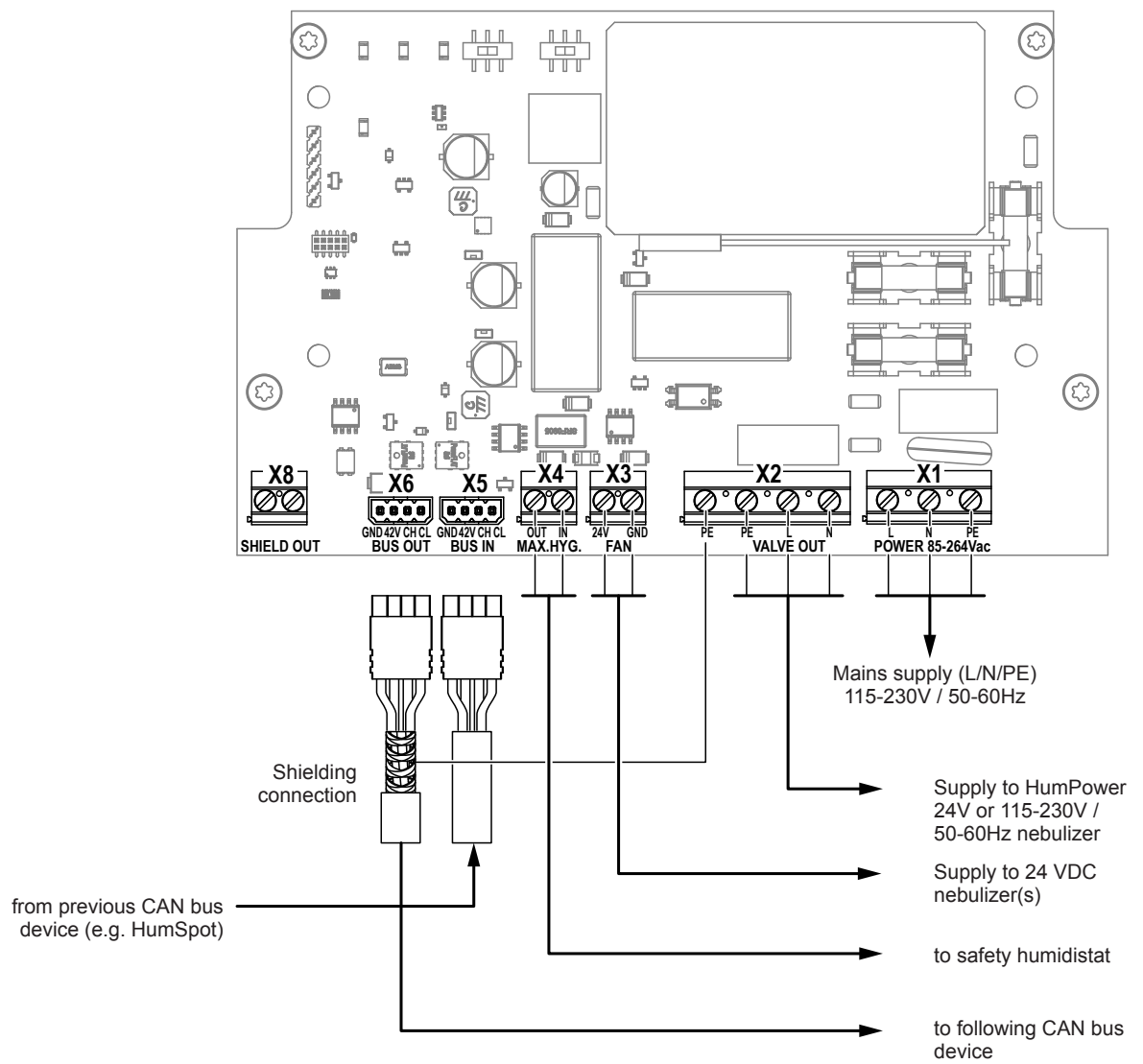

Fig. 43: HumPower wiring

Note: If no safety humidistat is connected to terminal block "X4", a cable bridge must be connected to the terminals "OUT" and "IN".

### 5.5.3 HumPower 24V connections

Each area equipped with more than three Vita Sky S/M1/M2 nebulizers for ring lines or with more than 10 Vita Sky S or 8 Vita Sky M1/M2 for string lines, must be equipped with a HumPower 24V connected to the HumPower (see also [Fig. 8](#) to [Fig. 11](#)).

Each HumPower 24V has the following connectors (see [Fig. 44](#)):

Terminals	Description
L, N and GND	Terminals (L/N/PE) for connecting the 115-230V, 50-60Hz power supply from the HumPower.
V+ and V-	Terminals (V+ and V-) for connecting the 24 V supply to the 24V nebulizers in the area. Note: If the area is equipped with a single 24 V nebulizer, this nebulizer is connected directly to V+ and V-. If the area is equipped with several 24 V nebulizers, the nebulizers are connected to the HumPower 24V via junction boxes.

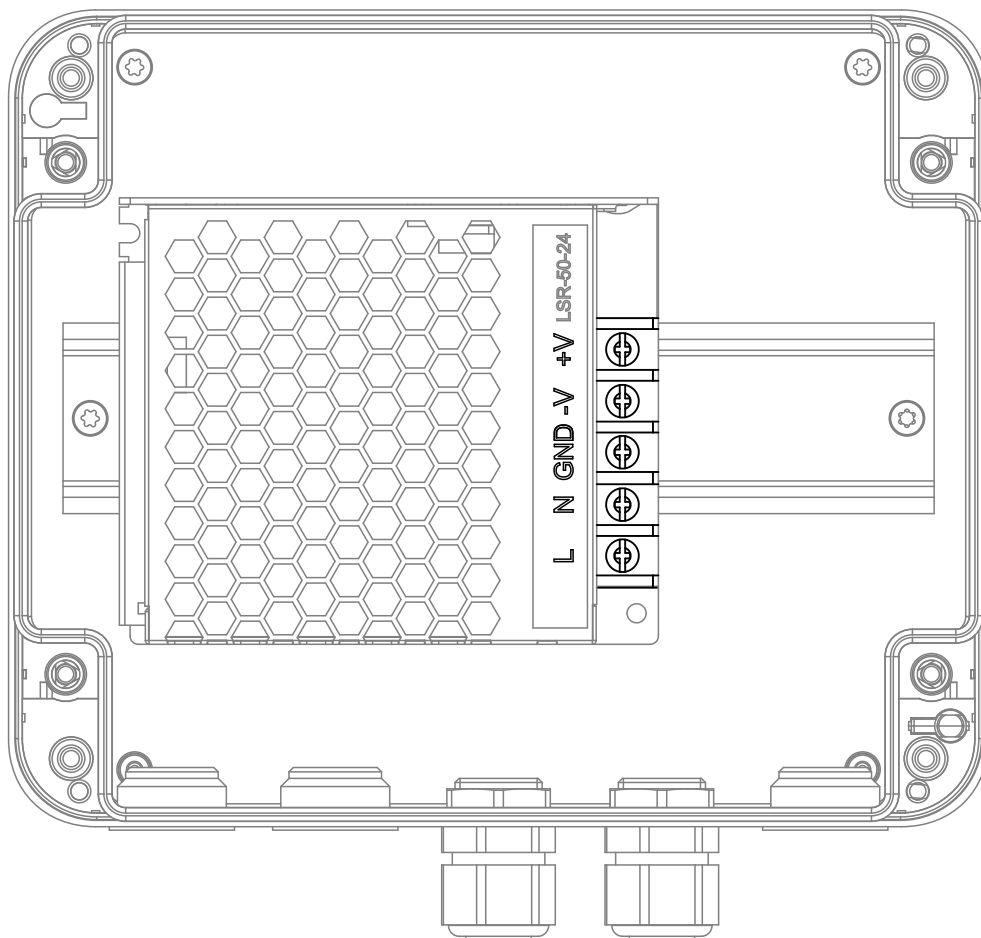

Fig. 44: HumPower 24 V connections

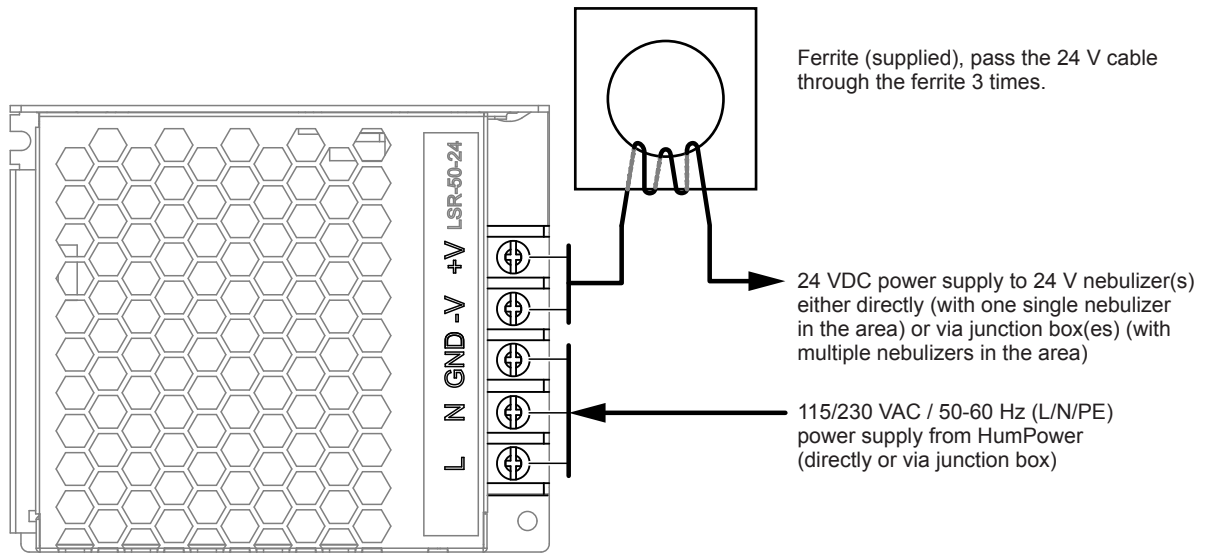

Fig. 45: HumPower 24 V wiring

### 5.5.4 24 VDC power supply to Condair Vita Sky S/M1/M2 nebulizers

All Condair Vita Sky S/M1/M2 nebulizers require 24 V supply for the integrated fan and the integrated valve (ring line models only).

Note: Nebulizer models for connection to string lines do not have a valve.

Connect the 24 VDC power supply for Condair Vita Sky S/M1/M2 nebulizers of an area as shown in [Fig. 46](#) using 2-core cables (2 x 0.5 mm<sup>2</sup>).

Note: In areas with one single "Condair Vita Sky S/M1/M2 nebulizer there is no junction box required. The power supply to the nebulizer can be connected directly to terminals "V+" and "V-" in the "HumPower 24V".

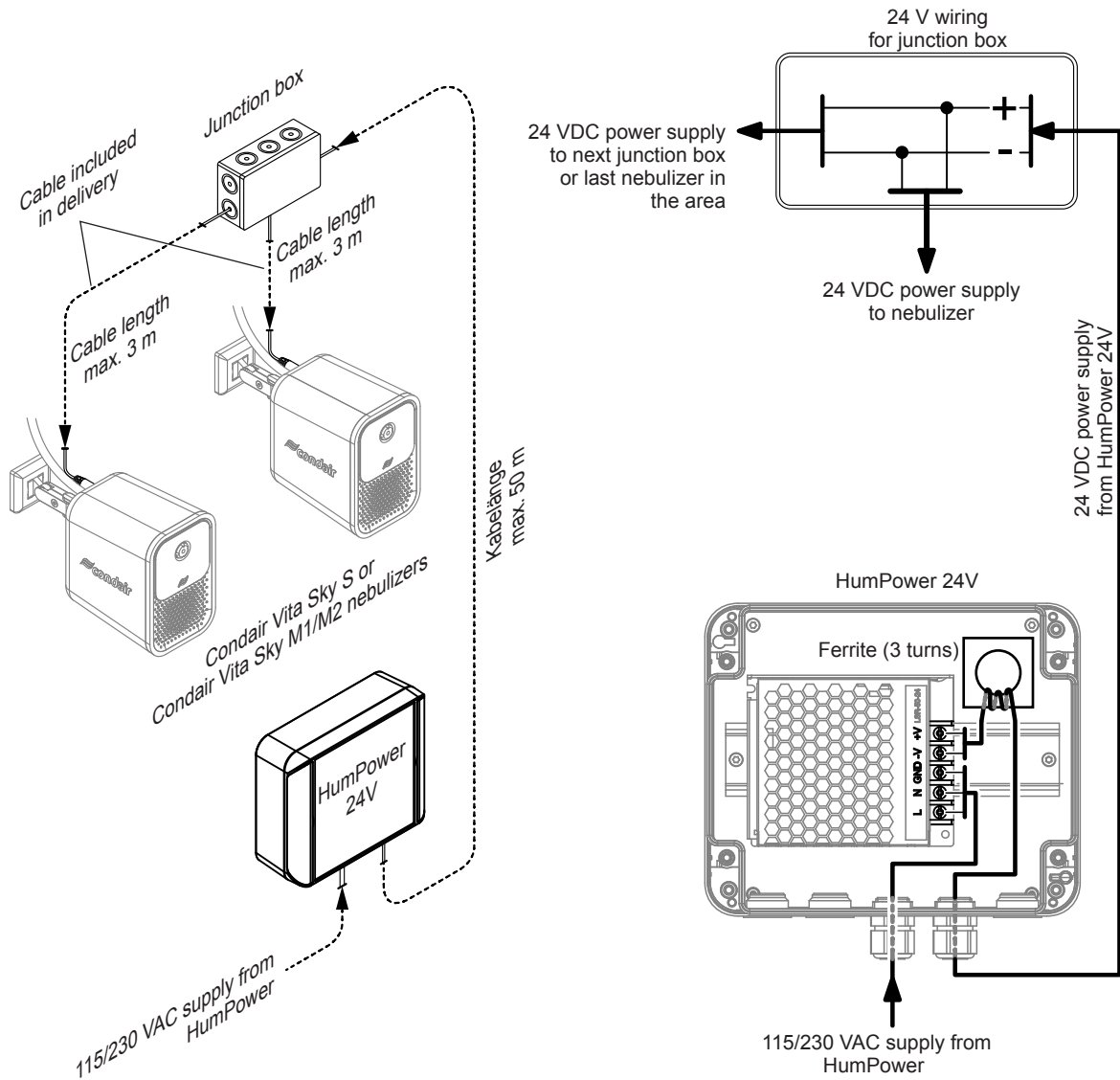

Fig. 46: 24 VDC power supply to Condair Vita Sky S/M1/M2 nebulizers

### 5.5.5 Connection of the zone valve for Condair Vita Sky S/M1/M2 string line nebulizers

Condair Vita Sky S/M1/M2 string line type nebulizers require a 24 VDC zone valve to control the water flow to the nebulizers in the appropriate area (see [Fig. 9](#) to [Fig. 11](#)). The corresponding wiring is shown in [Fig. 47](#) and [Fig. 48](#).

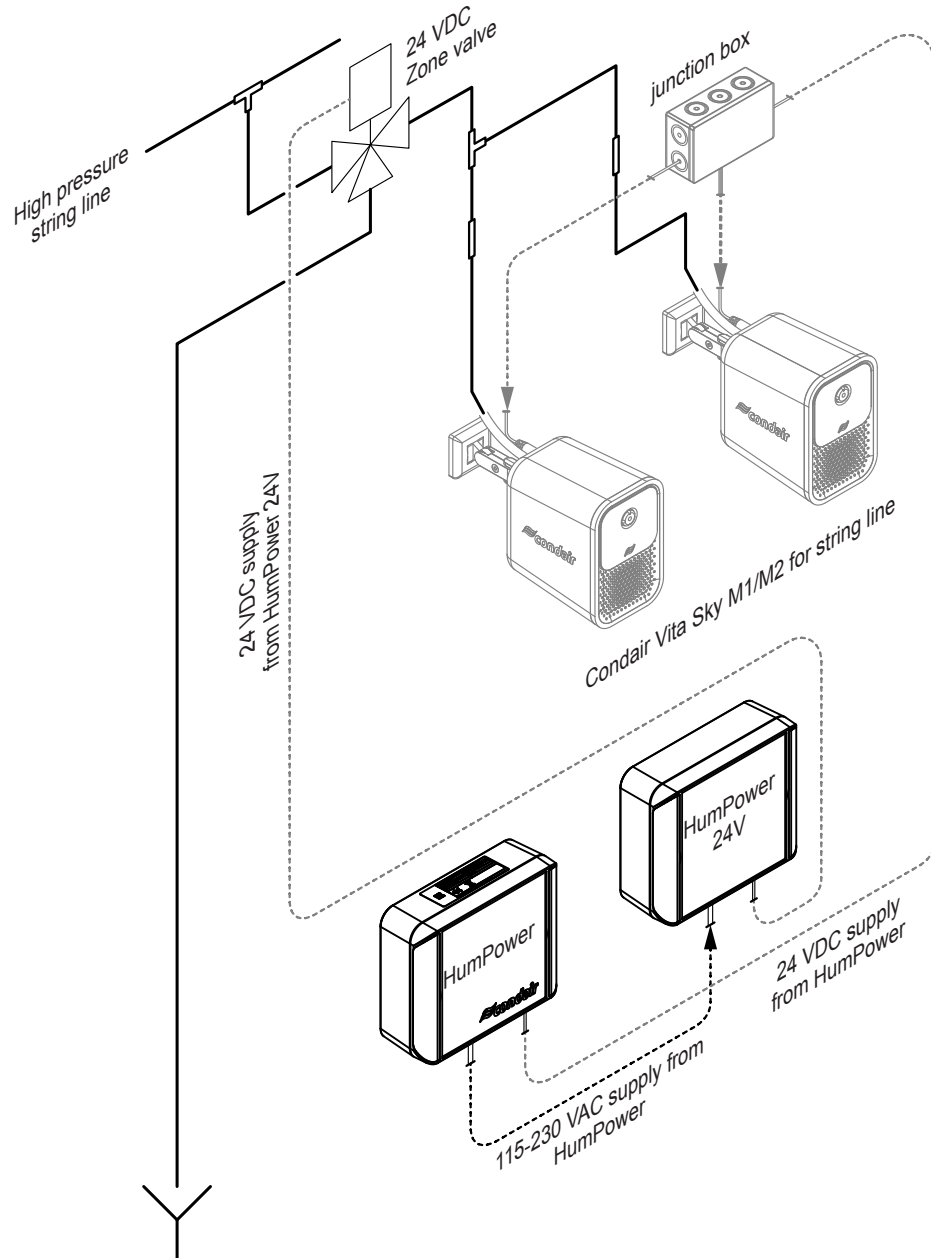

Fig. 47: Connection of the zone valve for Condair Vita Sky S/M1/M2 string line type nebulizers

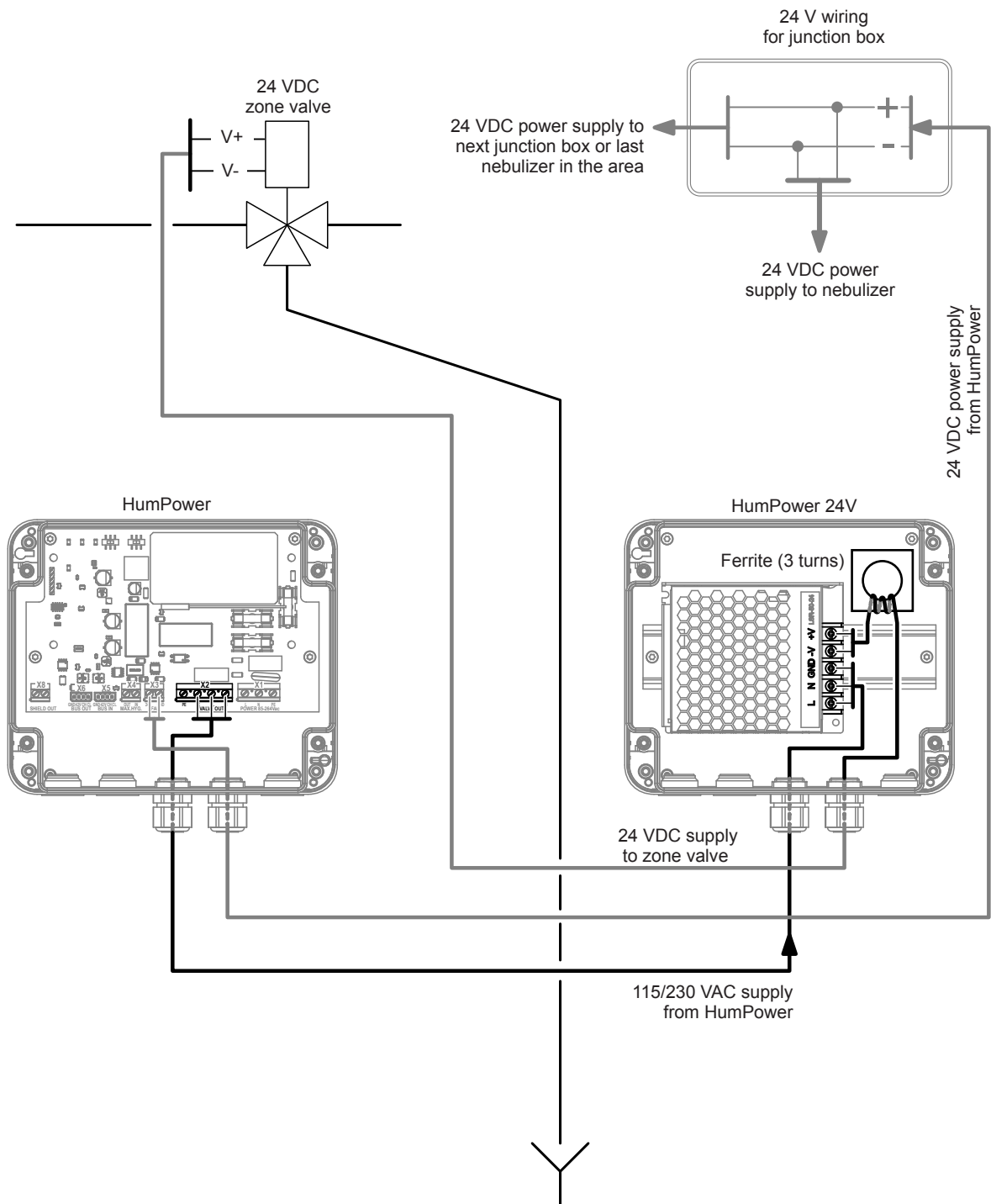

Fig. 48: Wiring of the zone valve for Condair Vita Sky S and Condair Vita Sky M1/M2 string line type nebulizers

### 5.5.6 24 VDC power supply for zone valve and 115/230 VAC power supply for Condair Vita Stream nebulizer

Condair Vita Stream nebulizers require 115/230 VAC power supply for the nebulizer and 24 VDC for the zone valve which is required to control the water flow to the nebulizer(s) in the appropriate area (see [Fig. 9](#) to [Fig. 11](#)).

For this reason junction box(es) and a HumPower 24V must be installed after the HumPower in order to supply the nebulizer(s) with 115/230 VAC and the zone valve with 24 VDC. The corresponding wiring is shown in [Fig. 49](#) and [Fig. 50](#).

Note: Additional nebulizer(s) in an area may require additional junction boxes in order to be able to connect the additional nebulizers.

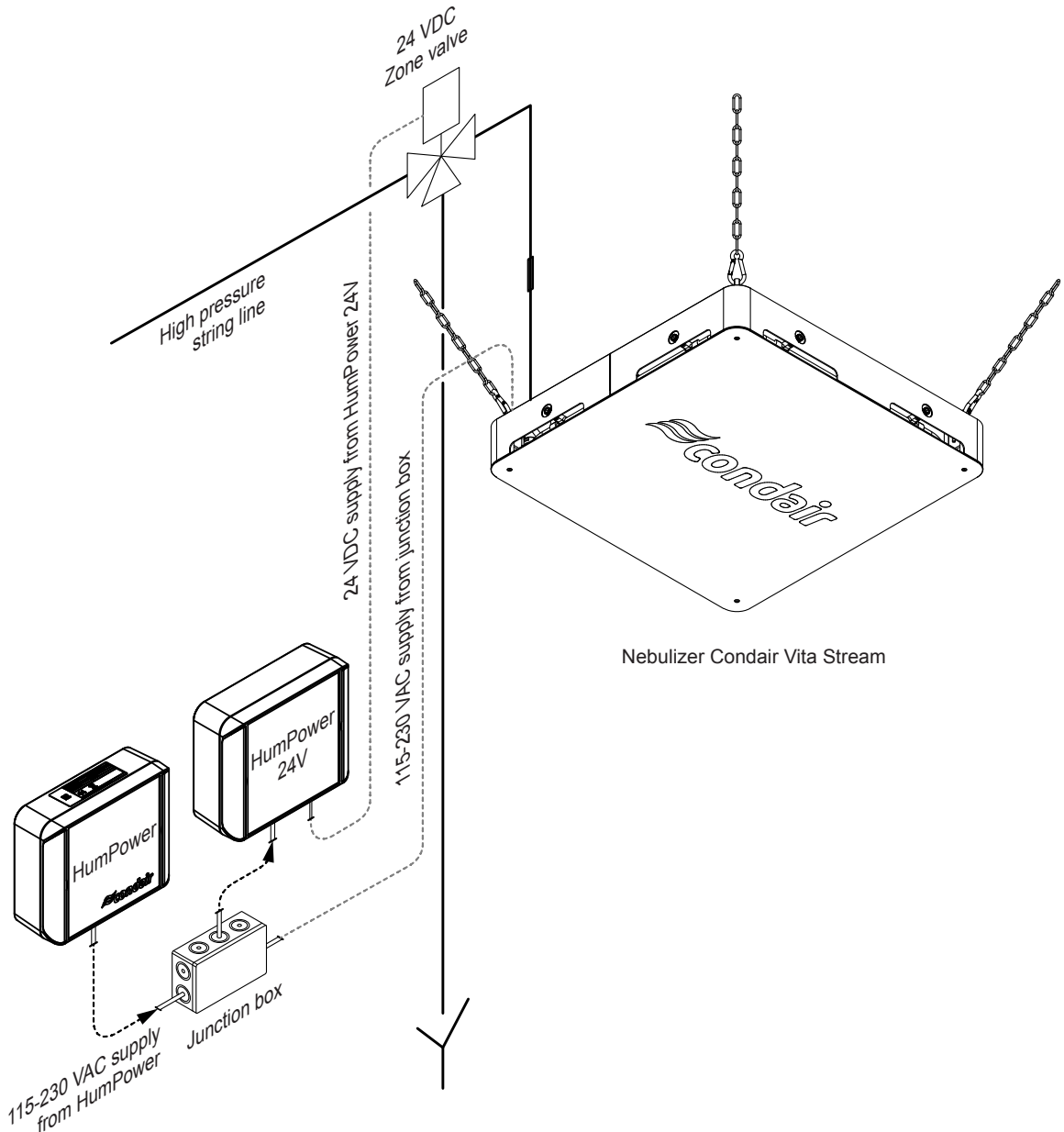

Fig. 49: 24 VDC power supply for zone valve and 115/230 VAC power supply for Condair Vita Stream nebulizer

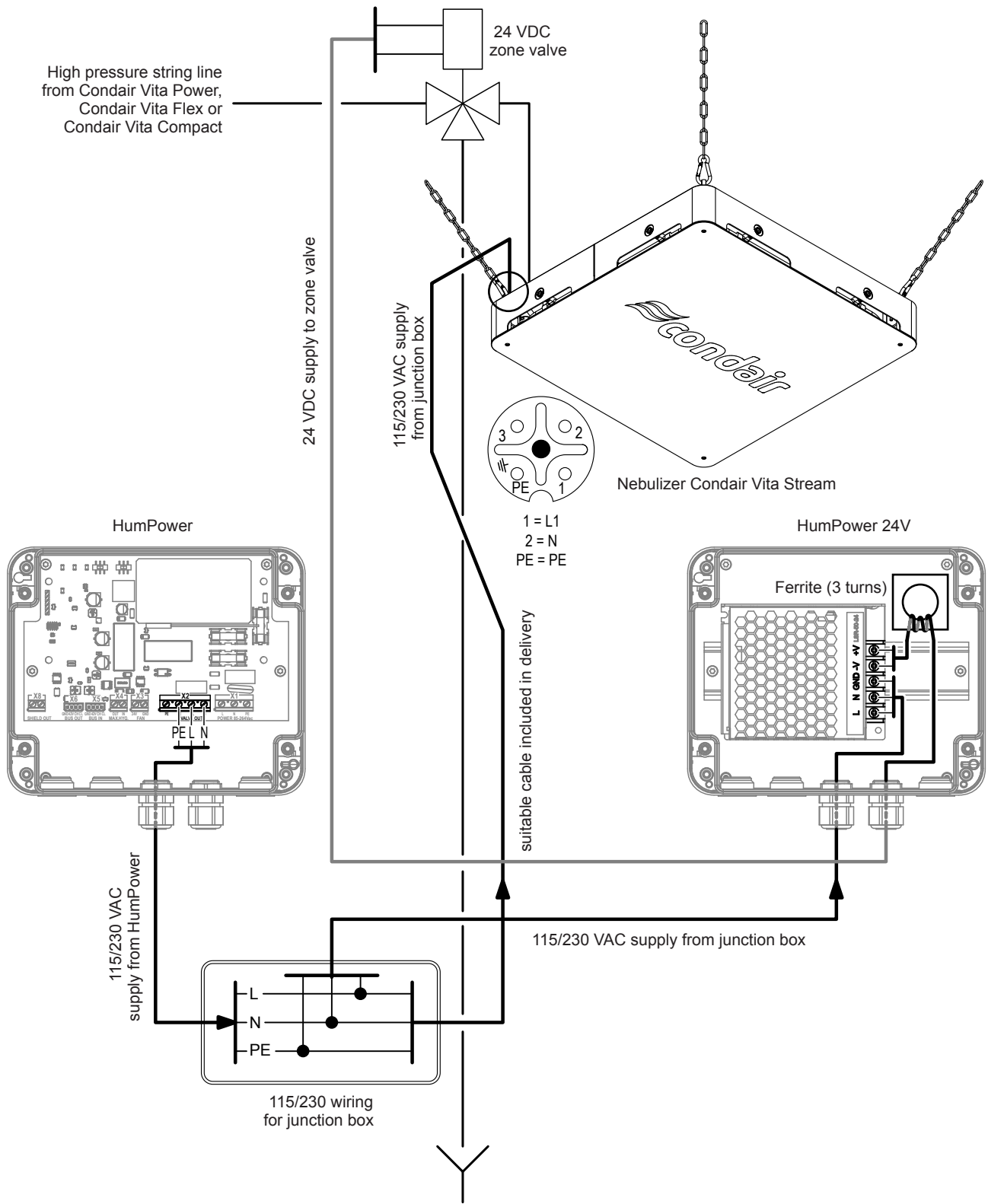
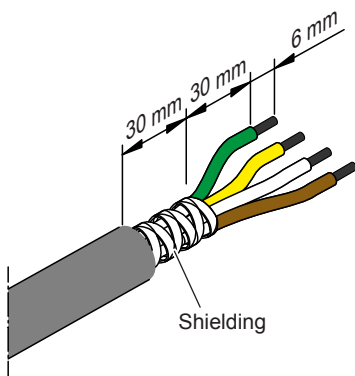

Fig. 50: Wiring of the zone valve and the Condair Vita Stream nebulizer



## Prepare the CAN bus cables

Strip the CAN bus cable



Attach ferrules

Attach ferrules 0.34 mm<sup>2</sup> x 6 mm with crimping pliers

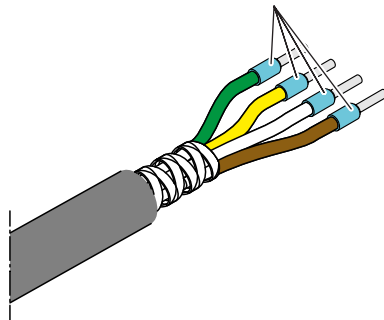

Connect CAN Bus plug

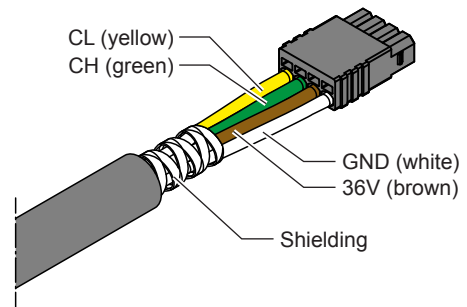

Fig. 52: CAN Bus Kabel vorbereiten

The following applies for the CAN bus net:

- Each device in the CAN bus net is called a node. The node numbering starts with the System Master (Node 1) and is increased by one for each unit in the net.
- The ASI switch of first device in a humidification area must be switched to "On" indicating that the area start here. All ASI switches of the remaining devices in the area are switched off. The position of the ASI switch in the CAN bus extender is ignored.

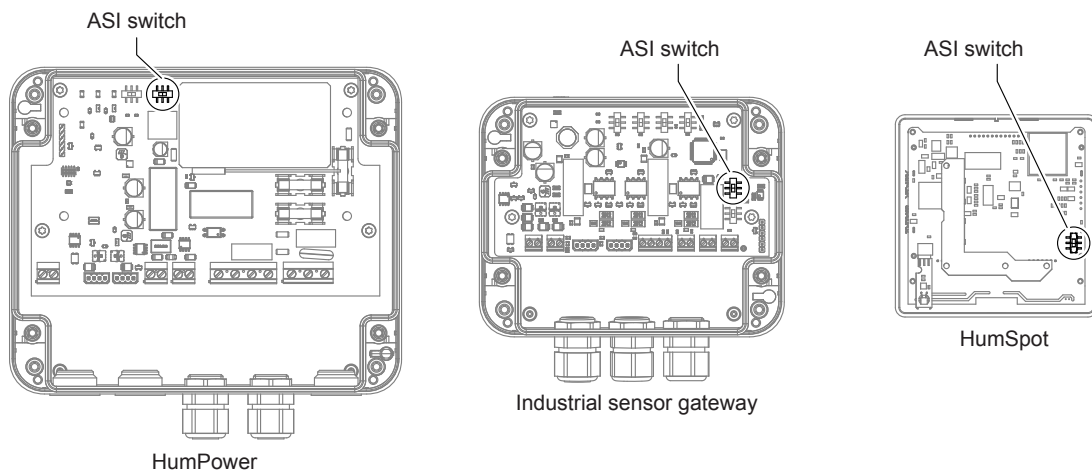

Fig. 53: Position of the ASI switch

- The shield of the CAN bus out cable must be connected to the corresponding ground in the device (see [Fig. 51](#)).  
Exception: In HumSpot devices and industrial sensor gateways the shield of both CAN bus cables must be connected together (e.g. with a WAGO terminal).
- In the last unit of the CAN bus net the CAN bus termination board must be connected to the CAN bus Out terminal.  
Note: The CAN bus termination board is supplied with the System Master.
- An area can be controlled without HumSpot and Industrial sensor.
- The connection order of the components in an area does not matter.
- A zone can have multiple HumPower(s) / HumSpot(s) and industrial humidity sensor(s) that can be connected via CAN bus.

## 5.6.1 Industrial sensor gateway connections and industrial sensor

Die Anschlüsse am Industriesensor Gateway sind für jeweils einen Industriesensor vorgesehen. Wird in einer Zone die externe Anforderung über das 4-20 mA Stromsignal geregelt, ist es nicht mehr möglich in dieser Zone den Sollwert der relativen Feuchte manuell zu konfigurieren. Aus diesem Grund schliessen sich der Betrieb mittels HumSpots und/oder mittels Industriesensor in Kombination mit einer externen Anforderung über das Stromsignal aus.

Jedes Industriesensor Gateway verfügt über die folgenden Anschlüsse und Mikroschalter (siehe [Fig. 54](#)):

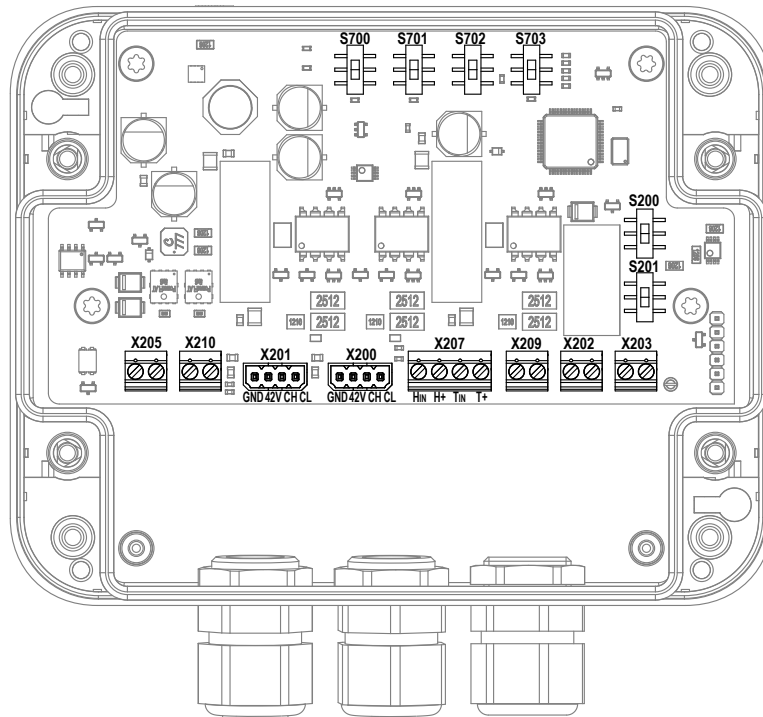

Fig. 54: Connections and microswitches in the industrial sensor gateway

Terminal block/ Microswitch	Description
X200 (BUS IN)	Socket to connect the industrial sensor gateway to the previous CAN bus device.
X201 (BUS OUT)	Socket to connect the industrial sensor gateway to the following CAN bus device. Note: If the industrial sensor gateway is the last device in the CAN bus net the bus termination board must be connected to this connector.
X202	?
X203	?
X205	?
X207 (Sensor)	Terminal block for connecting the industrial sensor.
X209	Terminal block for connecting a setpoint signal.
X210	Terminal block for connecting the CAN bus shields.
S200 (ASI)	Area Start Indicator Activate when the industrial sensor gateway is the first node in the zone.

<b>Terminal block/ Microswitch</b>	<b>Description</b>
S201 (Req)	Activate when a manual request signal is connected to terminal block X203.
S700 (Humid)	Activate when a humidity sensor is connected to terminals Hin and H+ of terminal block X207.
S701 (Temp)	Activate when a temperature sensor is connected to terminals Tin and T+ of terminal block X207.
S702 (T-Range)	Activate (temperature range: 0-100°C) when the Condair standard industrial sensor is connected to terminal block X209.
S703 (SetPoint)	Activate when a setpoint signal is connected to terminal block X209.

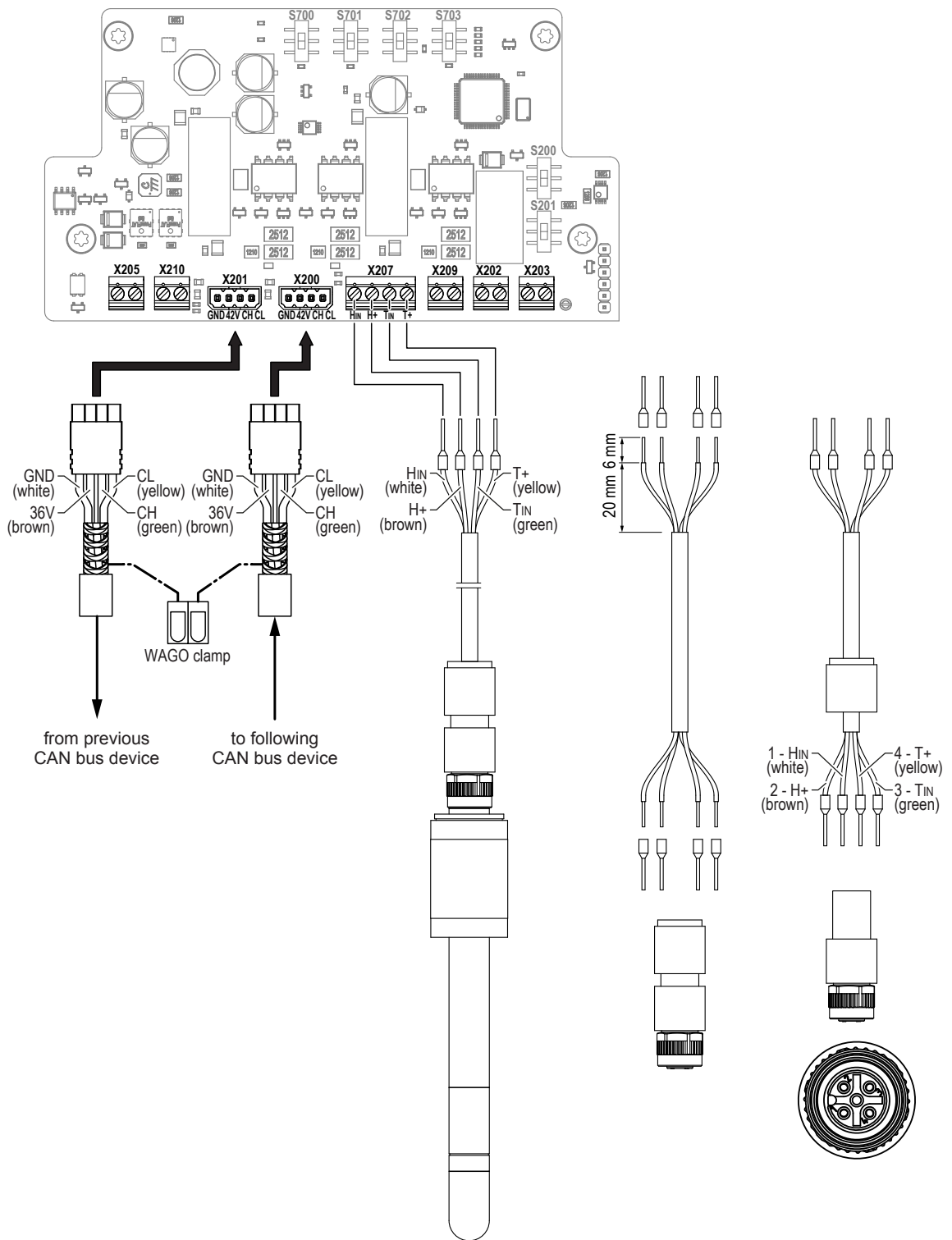

Fig. 55: Cabling of industrial sensor gateway and industrial sensor

Note: The sensor cable, the ferrules and the sensor plug are supplied as a set and must be assembled on site as shown in [Fig. 55](#)).

# 6 Operation

## 6.1 Initial commissioning

The initial commissioning of the direct room humidification system is always performed by a Condair service technician. The initial commissioning procedure is as follows:

1. Make sure that all spray heads are connected to the high-pressure line and electrically connected.
2. Check if the zone allocation is correct. The zone allocation is correct if the ASI switch for the first node in each zone is set to "ON" and all other nodes in the respective zone are set to "OFF" (see [Section 5.6](#)).
3. Switch on the Condair Vita water treatment system (see Condair Vita water treatment system operation manual).
4. Set the humidity setpoint value of the zones one after the other to 80% either via the control software of the water treatment system or on the HumSpot/safety humidistat to simulate a demand.
  - Check that all pipes and connections in the respective zone are tight. Repair any leaks.
  - Check that all spray heads in the respective zone are nebulizing without dripping and that the fans are running (except Vita Line). Correct any potential problems.
5. After checking the zones, reset the humidity setpoint value to the desired value.
6. Configure the humidity control of the zones using the water treatment system control software (see the water treatment system operation manual).

### Air in the high-pressure system

To remove any air from the high-pressure system, it can be helpful if the system or the spray heads are operated in a pulsating mode for about 15 minutes. To do this, before switching on the Condair Vita water treatment system, set the pulsation switch in the HumPower of each zone to "ON" (position of pulsation switch see [Fig. 42](#)). Then switch on the Condair Vita water treatment system and leave it switched on for about 15 minutes. During this time, the nebulizers are operated in a pulsating mode, regardless of the set humidity setpoint value of the zone. This will expel the air from the system. Turn off the Condair Vita water treatment system after 15 minutes and return the pulsation switch in the HumPower to "OFF."



**DANGER!**  
**Risk of electrocution**

The Condair HumPower works with mains voltage (115-230V AC, 50-60Hz).

Therefore: Before opening the HumPower, ensure that it is disconnected from the power supply and secured against accidental reconnection.



**CAUTION!**

If the system has not yet been leak tested, it must be done during pulsating operation.

## 6.2 Inspections during operation

During operation of the Condair Vita direct room humidification system, the system should be checked weekly. On this occasion check the following:

- the system for any leakage.
- the nebulizers and the other system components for correct fixing, any damage or malfunctions.
- the electric installations for any damage.

If the inspection reveals any irregularities (e.g. leakages, dripping nebulizers) or any damaged components take the Condair Vita direct room humidification system out of operation. Then, contact your Condair representative.

## 6.3 Shutting-down

To shut down the Condair Vita direct room humidification system, follow the instructions in the Condair Vita water treatment system operating manual.

## 7 Maintenance

---

Except for occasional external cleaning (removing dust and dirt buildup), the nebulizers and control devices require no maintenance.

For cleaning, use only a damp cloth, a brush or a vacuum cleaner on a low suction level.

## 8 Troubleshooting / replacement of defective components

### 8.1 Error list

The troubleshooting work highlighted in grey in the table may only be carried out by a Condair service technician or authorized specialist personnel.

If the fault cannot be resolved, contact your Condair representative

Fault	Possible cause	Remedy
<b>Nozzles drip</b>	Air in the (stub) line or system.	Perform a high-pressure line flush (see operation manual of the Condair Vita high pressure water treatment system). During the high-pressure line flush or during normal operation for 15 minutes, set the pulsation switch in the HumPower to ON. This will automatically set the zone to pulsating. This will expel the air from the system. Then, set the switch back to OFF. Please refer to the information in <a href="#">Section 6.1</a> .
	Conductivity value of the nebulizer water too low.	Check the CO <sub>2</sub> compressed gas cylinder.
<b>Poor spray pattern</b>	Integrated nozzle filter clogged.	Replace the nozzle as described in <a href="#">Section 8.2</a> .
	Fan or fan openings dirty.	Clean the fan openings with a vacuum cleaner. Replace the nebulizer if necessary (see <a href="#">Section 8.3</a> ).
	Nozzles dirty.	Replace the nozzle as described in <a href="#">Section 8.2</a> .

<b>Fault</b>	<b>Possible cause</b>	<b>Remedy</b>
<b>No nebulization takes place</b>	Target value limit exceeded or missing actuation signal	Wait until the target value limit is reached to switch on or increase the target value until the unit turns on
	Safety humidistat triggered.	Check whether the safety humidistat is triggered. If necessary, increase the set limit for commissioning up to 100% and reset it to the previously set value after commissioning.
	No or too low pressure in the high pressure system.	Brief interruptions (~15 minutes) may occur during a hygiene rinse or during pure water production. Wait for this time and check the error messages on the external control unit of the Condair Vita high pressure water treatment system.
	Power supply failure.	Check the building-side fuse protection of the HumPower control unit. Check error messages on the external control unit of the Condair Vita pure high pressure water treatment system.
	Overcurrent fuse in HumPower control unit tripped.	Determine the cause of the overcurrent fuse trip. If necessary, replace the fuse (1.5 A, slow-blow) in the HumPower.
<b>Tripping of the GFCI switch/overcurrent protection</b>	Earth fault or short circuit.	Check if another device on the same connector causes the same error. Return the defective device.
		Service unit and perform electrical safety check.
<b>Odor formation</b>	Zone switched off or out of operation for too long.	Disconnect the hydraulic connections to the affected nebulizer and contact your condair representative. The entire system must be disinfected.

## 8.2 Replacement of defective nozzles



### **CAUTION!** Risk of damage

When replacing a nozzle, avoid contact with the filter insert and nozzle opening. These could possibly be damaged during contact.

---

### **Replacement procedure**

- Disconnect the nebulizer from the high-pressure line system via the quick-release coupling or by closing the shut-off valve on the nebulizer.
- Have a bucket ready to catch the escaping water.
- Unscrew the nozzle(s) from the nebulizer.
- Make sure the seal on the nozzle(s) is/are in place. Screw the new nozzle(s) into the nebulizer.
- Restart the system and check the spray pattern.

Note: When commissioning after replacing nozzles, please note that a drip-free shutdown of the nebulizer will only occur after switching the system on and off several times. Therefore, it is essential to protect/cover any items and equipment underneath the nebulizer.



### **CAUTION!** Leakage check

Once the system is back in operation, look out for any leakages. Check the system occasionally over the next two days.

---

### **Returning defective nozzles**

The defective nozzles must be returned to the Condair representative in the original packaging of the nozzle set.

## 8.3 Replacing the defective nebulizers

### Replacement procedure

- Disconnect the power supply cable to the nebulizer.
- This step is only required for nebulizers with a "Premium" ceiling mount: Loosen the knurled nut on the ceiling mount and carefully pull the ceiling mount down a little to access the high-pressure quick coupling.
- Have a bucket ready to catch the escaping water.
- Disconnect the hydraulic supply line via the high-pressure quick coupling.
- For nebulizers with a "Premium" ceiling bracket, pull the power cable out of the ceiling bracket tube.
- Lift the Condair Vita Sky S/M nebulizer from the support arm or loosen the chains of the Condair Vita Stream or Vita Space nebulizer.
- Make sure that no water has got into the electrical connection and install the new nebulizer in reverse order.
- Restart the system and check the spray pattern.  
Note: When commissioning after replacing nozzles, please note that a drip-free shutdown of the nebulizer will only occur after switching the system on and off several times. Therefore, it is essential to protect/cover any items and equipment underneath the nebulizer.



**CAUTION!**  
**Leakage check**

Once the system is back in operation, look out for any leakages. Check the system occasionally over the next two days.

---

### Returning defective nebulizers

Defective nebulizers must be returned to your Condair representative in their original packaging.

**Notes**

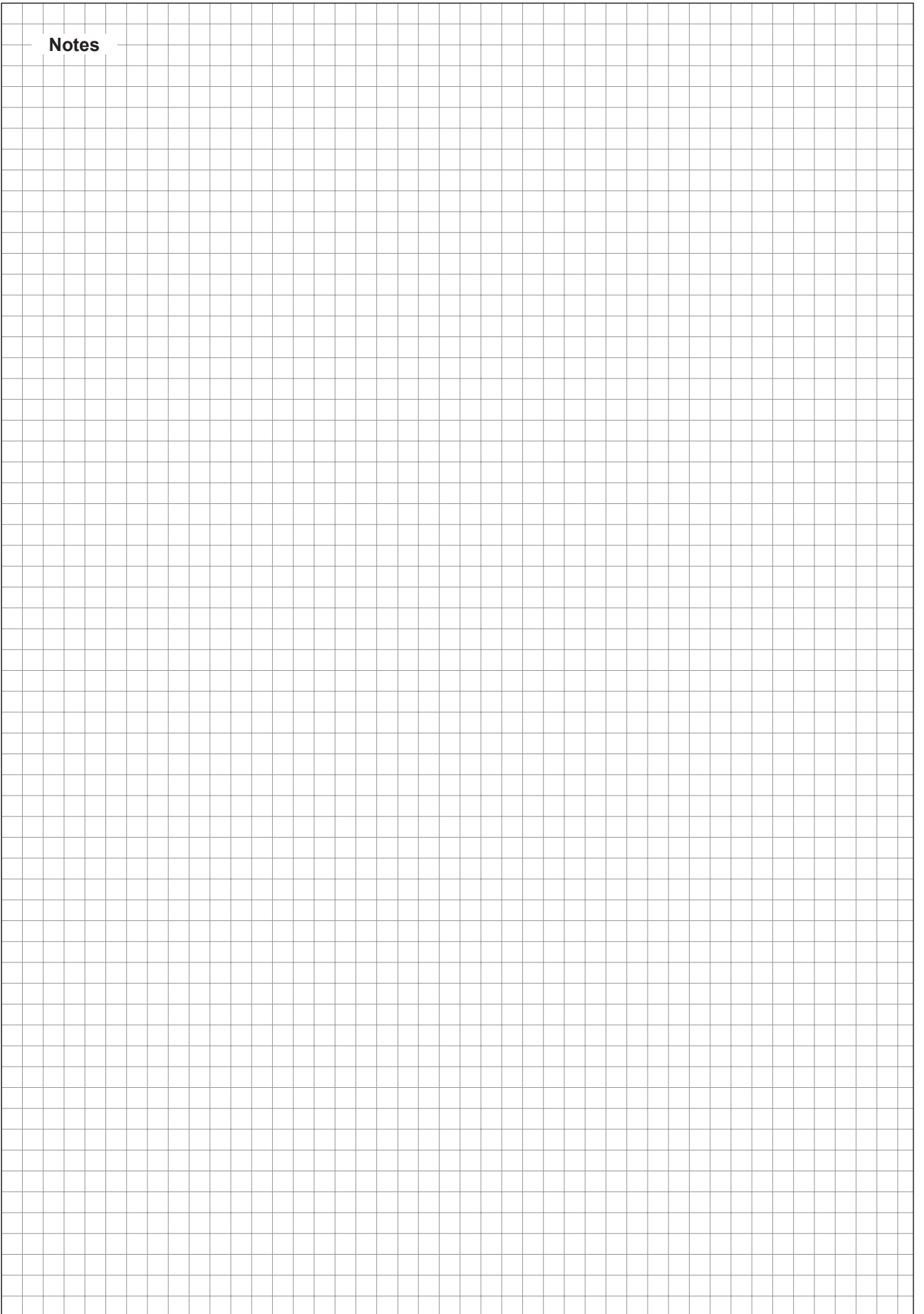

Notes



CONSULTING, SALES AND SERVICE:



CH94/0002.00

Condair Group AG  
Gwattstrasse 17, 8808 Pfäffikon SZ, Switzerland  
Phone +41 55 416 61 11, Fax +41 55 588 00 07  
info@condair.com, www.condairgroup.com

 **condair**